

Instruction

MI 021-517 en

APR 2020

Model IMT30A Magnetic Flow Transmitter

Master Instruction

All rights reserved. It is prohibited to reproduce this documentation, or any part thereof, without the prior written authorisation of Schneider Electric Systems USA, Inc.

Copyright 2019-2020 Schneider Electric Systems USA, Inc.

1	Safety instructions	6
<hr/>		
1.1	Software history	6
1.2	Intended use	7
1.3	Certifications	7
1.4	Safety instructions from the manufacturer	8
1.4.1	Copyright and data protection	8
1.4.2	Disclaimer	8
1.4.3	Product liability and warranty	9
1.4.4	Information concerning the documentation	9
1.4.5	Warnings and symbols used	10
1.5	Safety instructions for the operator	11
2	Device description	12
<hr/>		
2.1	Scope of delivery	12
2.2	Device description	13
2.3	Nameplates	14
3	Installation	15
<hr/>		
3.1	General notes on installation	15
3.2	Storage	15
3.3	Transport	15
3.4	Installation specifications	15
3.5	Mounting of the compact version	16
3.6	Mounting of the wall housing, remote version	16
4	Electrical connections	18
<hr/>		
4.1	Safety instructions	18
4.2	Important notes on electrical connection	18
4.3	Electrical cables for remote device versions, notes	19
4.3.1	Notes on signal cable A	19
4.3.2	Notes on field current cable C	19
4.3.3	Requirements for signal cables provided by the customer	20
4.4	Preparing the signal and field current cables	21
4.4.1	Signal cable A (type DS 300), construction	21
4.4.2	Preparing signal cable A, connection to transmitter	22
4.4.3	Length of signal cable A	23
4.4.4	Preparing field current cable C, connection to transmitter	24
4.4.5	Preparing signal cable A, connection to flow tube	26
4.4.6	Preparing field current cable C, connection to flow tube	27
4.5	Connecting the signal and field current cables	28
4.5.1	Connecting the signal and field current cables to the transmitter, remote version	29
4.5.2	Connection diagram for signal and field current cable	30

4.6	Grounding the flow tube	31
4.7	Connecting the power supply	31
4.8	Inputs and outputs, overview	33
4.8.1	Description of the CG number	33
4.8.2	Fixed, non-alterable output versions	33
4.9	Description of the inputs and outputs	34
4.9.1	Current output	34
4.9.2	Pulse output and frequency output	35
4.9.3	Status output and limit switch	36
4.10	Electrical connection of the outputs	37
4.10.1	Electrical connection of the outputs	37
4.10.2	Laying electrical cables correctly	38
4.11	Connection diagrams of outputs	38
4.11.1	Important notes	38
4.11.2	Description of the electrical symbols	39
4.11.3	Basic and Modbus outputs	40
4.11.4	HART connection	45
5	Start-up	47
<hr/>		
5.1	Switching on the power	47
5.2	Starting the transmitter	47
6	Operation	48
<hr/>		
6.1	Safety instructions for the use of the magnet pencil	48
6.2	Display and operating elements	48
6.2.1	Display in measuring mode with 2 or 3 measured values	50
6.2.2	Display for selection of submenu and functions, 3 lines	50
6.2.3	Display when setting parameters, 4 lines	51
6.2.4	Display when previewing parameters, 4 lines	52
6.3	Menu structure	53
6.4	Function tables	55
6.4.1	Menu "A quick setup"	55
6.4.2	Menu "B test"	57
6.4.3	Menu "C setup"	58
6.4.4	Set free units	67
6.5	Description of functions	68
6.5.1	Reset counter in the menu "quick setup"	68
6.5.2	Deleting error messages in the menu "quick setup"	68
6.6	Status messages and diagnostic information	69

7 Service	73
7.1 Spare parts availability.....	73
7.2 Availability of services	73
7.3 Returning the device to the manufacturer.....	73
7.3.1 General information.....	73
7.3.2 Preapproval form - Customer returned process-wetted products.....	74
7.4 Disposal	75
8 Technical data	76
8.1 Measuring principle.....	76
8.2 Technical data.....	77
8.3 Dimensions and weight	84
8.3.1 Housing	84
8.3.2 Mounting plate, wall version.....	86
8.4 Flow tables	87
8.5 Measuring accuracy	89
9 Notes	90

1.1 Software history

The "Electronic Revision" (ER) is consulted to document the revision status of electronic equipment according to NE 53 for all devices. It is easy to see from the ER whether troubleshooting or larger changes in the electronic equipment have taken place and how that has affected the compatibility.

1	Downwards compatible changes and fault repair with no effect on operation (e.g. spelling mistakes on display)	
2- <u> </u>	Downwards compatible hardware and/or software change of interfaces:	
	H	HART®
	M	Modbus
	X	all interfaces
3- <u> </u>	Downwards compatible hardware and/or software change of inputs and outputs:	
	I	Current output
	F, P	Frequency / pulse output
	S	Status output
	L	Limit switch
	X	all inputs and outputs
4	Downwards compatible changes with new functions	
5	Incompatible changes, i.e. electronic equipment must be changed	

Table 1-1: Description of changes



NOTICE!

In the table below, " _ " is a placeholder for possible multi-digit alphanumeric combinations, depending on the available version.

Release date	Electronic revision	Changes and compatibility	Issue date of documentation
2016	ER3.0.3_	Initial version	FEB 2016
2017	ER3.0.3_	-	MAY 2017 APR 2020

Table 1-2: Changes and effect on compatibility

1.2 Intended use

The electromagnetic flowmeters are designed exclusively to measure the flow and conductivity of electrically conductive, liquid media.

**WARNING!**

If the device is not used according to the operating conditions (refer to chapter "Technical data"), the intended protection could be affected.

**NOTICE!**

This device is a Group 1, Class A device as specified within CISPR11:2009. It is intended for use in industrial environment. There may be potential difficulties in ensuring electromagnetic compatibility in other environments, due to conducted as well as radiated disturbances.

1.3 Certifications

CE marking



The manufacturer certifies successful testing of the product by applying the CE mark.

This device fulfils the statutory requirements of the relevant EU directives.

For full information of the EU directives and standards and the approved certifications, please refer to the EU Declaration of Conformity or the website of the manufacturer.

Other approvals and standards

- NAMUR recommendations NE 21 and NE 43

1.4 Safety instructions from the manufacturer

1.4.1 Copyright and data protection

The contents of this document have been created with great care. Nevertheless, we provide no guarantee that the contents are correct, complete or up-to-date.

The contents and works in this document are subject to copyright. Contributions from third parties are identified as such. Reproduction, processing, dissemination and any type of use beyond what is permitted under copyright requires written authorisation from the respective author and/or the manufacturer.

The manufacturer tries always to observe the copyrights of others, and to draw on works created in-house or works in the public domain.

The collection of personal data (such as names, street addresses or e-mail addresses) in the manufacturer's documents is always on a voluntary basis whenever possible. Whenever feasible, it is always possible to make use of the offerings and services without providing any personal data.

We draw your attention to the fact that data transmission over the Internet (e.g. when communicating by e-mail) may involve gaps in security. It is not possible to protect such data completely against access by third parties.

We hereby expressly prohibit the use of the contact data published as part of our duty to publish an imprint for the purpose of sending us any advertising or informational materials that we have not expressly requested.

1.4.2 Disclaimer

The manufacturer will not be liable for any damage of any kind by using its product, including, but not limited to direct, indirect or incidental and consequential damages.

This disclaimer does not apply in case the manufacturer has acted on purpose or with gross negligence. In the event any applicable law does not allow such limitations on implied warranties or the exclusion of limitation of certain damages, you may, if such law applies to you, not be subject to some or all of the above disclaimer, exclusions or limitations.

Any product purchased from the manufacturer is warranted in accordance with the relevant product documentation and our Terms and Conditions of Sale.

The manufacturer reserves the right to alter the content of its documents, including this disclaimer in any way, at any time, for any reason, without prior notification, and will not be liable in any way for possible consequences of such changes.

1.4.3 Product liability and warranty

The operator shall bear responsibility for the suitability of the device for the specific purpose. The manufacturer accepts no liability for the consequences of misuse by the operator. Improper installation or operation of the devices (systems) will cause the warranty to be void. The respective "Standard Terms and Conditions" which form the basis for the sales contract shall also apply.

1.4.4 Information concerning the documentation

To prevent any injury to the user or damage to the device it is essential that you read the information in this document and observe applicable national standards, safety requirements and accident prevention regulations.

If this document is not in your native language and if you have any problems understanding the text, we advise you to contact your local office for assistance. The manufacturer can not accept responsibility for any damage or injury caused by misunderstanding of the information in this document.

This document is provided to help you establish operating conditions, which will permit safe and efficient use of this device. Special considerations and precautions are also described in the document, which appear in the form of icons as shown below.

1.4.5 Warnings and symbols used

Safety warnings are indicated by the following symbols.

**DANGER!**

This warning refers to the immediate danger when working with electricity.

**DANGER!**

This warning refers to the immediate danger of burns caused by heat or hot surfaces.

**DANGER!**

This warning refers to the immediate danger when using this device in a hazardous atmosphere.

**DANGER!**

These warnings must be observed without fail. Even partial disregard of this warning can lead to serious health problems and even death.

**WARNING!**

Disregarding this safety warning, even if only in part, poses the risk of serious health problems. There is also the risk of damaging the device or parts of the operator's plant.

**CAUTION!**

Disregarding these instructions can result in damage to the device or to parts of the operator's plant.

**NOTICE!**

These instructions contain important information for the handling of the device.

**LEGAL NOTICE!**

This note contains information on statutory directives and standards.

• **HANDLING**

This symbol designates all instructions for actions to be carried out by the operator in the specified sequence.

➔ **RESULT**

This symbol refers to all important consequences of the previous actions.

1.5 Safety instructions for the operator

**WARNING!**

In general, devices from the manufacturer may only be installed, commissioned, operated and maintained by properly trained and authorized personnel.

This document is provided to help you establish operating conditions, which will permit safe and efficient use of this device.

2.1 Scope of delivery

**NOTICE!**

Inspect the packaging carefully for damages or signs of rough handling. Report damage to the carrier and to the local office of the manufacturer.

**NOTICE!**

Do a check of the packing list to make sure that you have all the elements given in the order.

**NOTICE!**

Look at the device nameplate to ensure that the device is delivered according to your order. Check for the correct supply voltage printed on the nameplate.

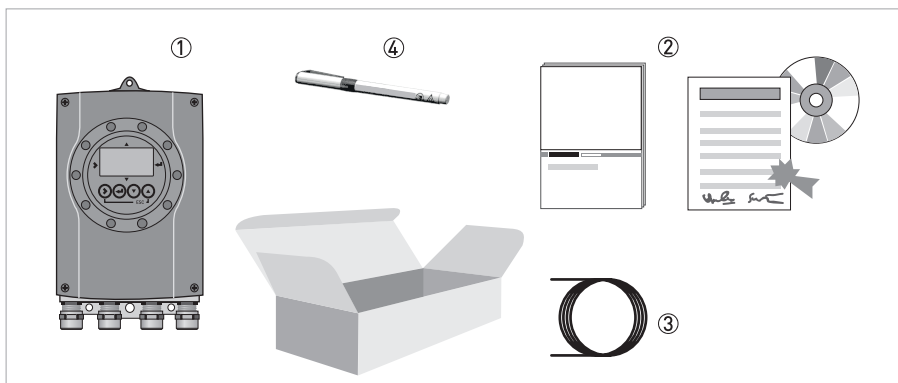

Figure 2-1: Scope of delivery

- ① Device in the version as ordered
- ② Magnet pencil (to operate the transmitter when the housing is closed)
- ③ Documentation (calibration report, DVD with product documentation for flow tube and transmitter)
- ④ Signal cable (only for remote version)

2.2 Device description

Electromagnetic flowmeters are designed exclusively to measure the flow and conductivity of electrically conductive, liquid media.

Your measuring device is supplied ready for operation. The factory settings for the operating data have been made in accordance with your order specifications.

The following versions are available:

- Compact version (the transmitter is mounted directly on the flow tube)
- Remote version (electrical connection to the flow tube via field current and signal cable)

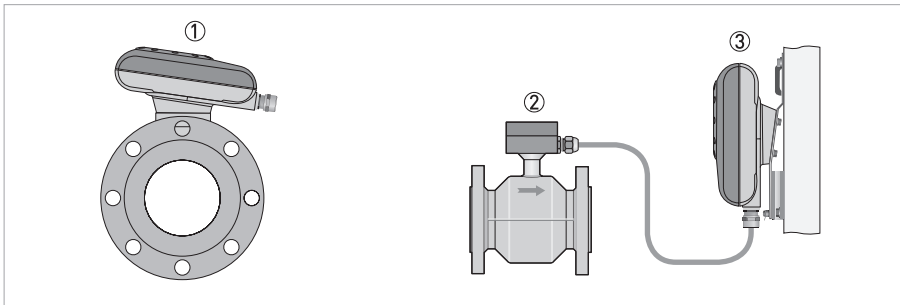

Figure 2-2: Device versions

- ① Compact version
- ② Flow tube with connection box
- ③ Wall version

2.3 Nameplates



NOTICE!

Look at the device nameplate to ensure that the device is delivered according to your order. Check for the correct supply voltage printed on the nameplate.

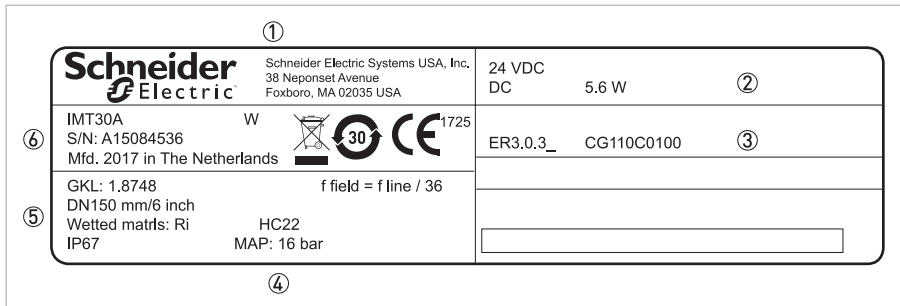

Figure 2-3: Example of a nameplate

- ① Manufacturer address
- ② Data for power supply
- ③ Software revision number (Electronic Revision)
- ④ Maximum working pressure
- ⑤ GK/GKL values (flow tube constants), size (mm/inch), field frequency, ingress protection and materials of wetted parts
- ⑥ Product designation, serial number, manufacturing date and country, disposal and China RoHs marking

3.1 General notes on installation

**NOTICE!**

Inspect the packaging carefully for damages or signs of rough handling. Report damage to the carrier and to the local office of the manufacturer.

**NOTICE!**

Do a check of the packing list to make sure that you have all the elements given in the order.

**NOTICE!**

Look at the device nameplate to ensure that the device is delivered according to your order. Check for the correct supply voltage printed on the nameplate.

3.2 Storage

- Store the device in a dry, dust-free location.
- Avoid continuous direct sunlight.
- Store the device in its original packing.
- Storage temperature: -40...+70°C / -40...+158°F

3.3 Transport

Transmitter

- No special requirements.

Compact version

- Do not lift the device by the transmitter housing.
- Do not use lifting chains.
- To transport flange devices, use lifting straps. Wrap these around both process connections.

3.4 Installation specifications

**NOTICE!**

The following precautions must be taken to ensure reliable installation.

- *Make sure that there is adequate space to the sides.*
- *The device must not be heated by radiated heat (e.g. exposure to the sun) to an electronics housing surface temperature above the maximum permissible ambient temperature. If it is necessary to prevent damage from heat sources, a heat protection (e.g. sun shade) has to be installed.*
- *Transmitters installed in control cabinets require adequate cooling, e.g. by fan or heat exchanger.*
- *Do not expose the transmitter to intense vibrations. The measuring devices are tested for a vibration level as described in the chapter "Technical data".*

3.5 Mounting of the compact version



NOTICE!

The transmitter is mounted directly on the flow tube. For installation of the flowmeter, please observe the instructions in the supplied product documentation for the flow tube.

3.6 Mounting of the wall housing, remote version



NOTICE!

Assembly materials and tools are not part of the delivery. Use the assembly materials and tools in compliance with the applicable occupational health and safety directives.

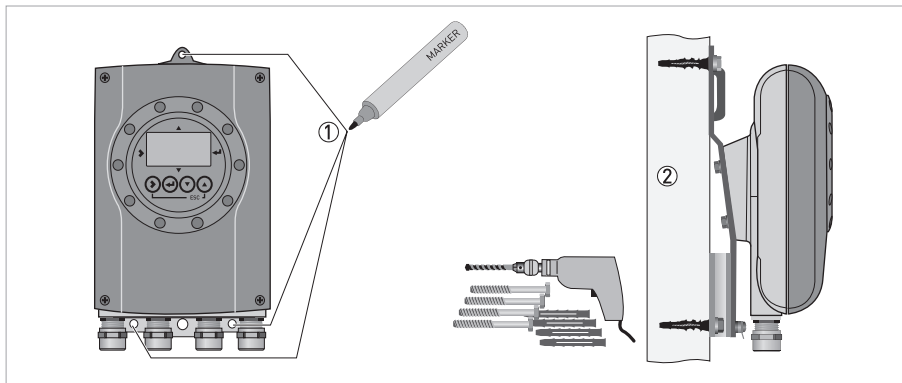

Figure 3-1: Mounting of the wall housing



- ① Prepare the holes with the aid of the mounting plate. For further information refer to *Mounting plate, wall version* on page 86.
- ② Fasten the device securely to the wall with the mounting plate.

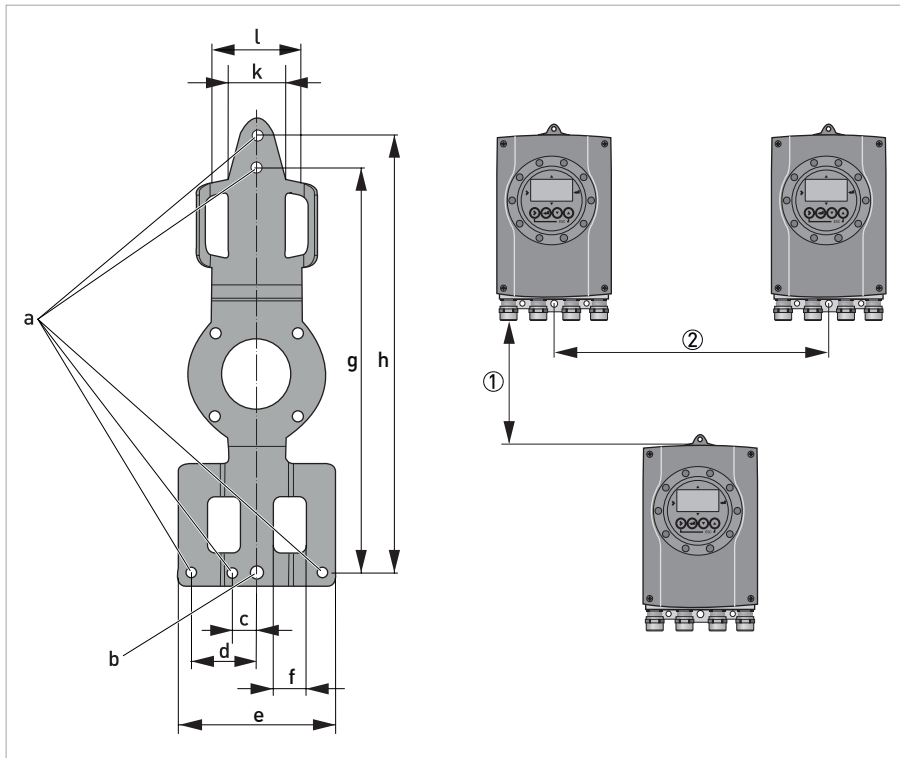

Figure 3-2: Dimensions of mounting plate and distances when mounting multiple devices next to each other

- ① 277 mm / 10.89"
- ② 310 mm / 12.2"

	[mm]	[inch]
a	Ø6.5	Ø0.26
b	Ø8.1	Ø0.3
c	15	0.6
d	40	1.6
e	96	3.8
f	20	0.8
g	248	9.8
h	268	10.5
k	35	1.4
l	55	2.2

Table 3-1: Dimensions in mm and inch

4.1 Safety instructions



DANGER!

All work on the electrical connections may only be carried out with the power disconnected. Take note of the voltage data on the nameplate!



DANGER!

Observe the national regulations for electrical installations!



WARNING!

Observe without fail the local occupational health and safety regulations. Any work done on the electrical components of the measuring device may only be carried out by properly trained specialists.



NOTICE!

Look at the device nameplate to ensure that the device is delivered according to your order. Check for the correct supply voltage printed on the nameplate.

4.2 Important notes on electrical connection



DANGER!

Electrical connection is carried out in conformity with the VDE 0100 directive "Regulations for electrical power installations with line voltages up to 1000 V" or equivalent national specifications.



CAUTION!

- *Use suitable cable entries for the various electrical cables.*
- *The flow tube and transmitter have been configured together at the factory. For this reason, please connect the devices in pairs. Ensure that the flow tube constant GKL (refer to information on the nameplates) are identically set.*
- *If delivered separately or when installing devices that were not configured together, set the transmitter to the DN size and GKL of the flow tube, refer to Function tables on page 55.*

4.3 Electrical cables for remote device versions, notes

4.3.1 Notes on signal cable A

**NOTICE!**

Signal cable A (type DS 300) with double shield ensures proper transmission of measured values.

Observe the following notes:

- Lay the signal cable with fastening elements.
- It is permissible to lay the signal cable in water or in the ground.
- The insulating material is flame-retardant.
- The signal cable does not contain any halogens and is unplasticized, and remains flexible at low temperatures.
- The connection of the inner shield (10) is carried out via the stranded drain wire (1).
- The connection of the outer shield (60) is carried out via the stranded drain wire (6).

4.3.2 Notes on field current cable C

**DANGER!**

*A shielded 2-wire copper cable is used for the field current cable. The shielding **MUST** be connected in the housing of the flow tube and transmitter.*

**NOTICE!**

The field current cable is not part of the scope of delivery.

4.3.3 Requirements for signal cables provided by the customer

**NOTICE!**

If the signal cable was not ordered, it is to be provided by the customer. The following requirements regarding the electrical values of the signal cable must be observed:

Electrical safety

- According to low voltage directive or equivalent national regulations.

Capacitance of the insulated conductors

- Insulated conductor / insulated conductor < 50 pF/m
- Insulated conductor / shield < 150 pF/m

Insulation resistance

- $R_{i50} > 100 \text{ G}\Omega \times \text{km}$
- $U_{\text{max}} < 24 \text{ V}$
- $I_{\text{max}} < 100 \text{ mA}$

Test voltages

- Insulated conductor / inner shield 500 V
- Insulated conductor / insulated conductor 1000 V
- Insulated conductor / outer shield 1000 V

Twisting of the insulated conductors

- At least 10 twists per meter, important for screening magnetic fields.

4.4 Preparing the signal and field current cables



NOTICE!

Assembly materials and tools are not part of the delivery. Use the assembly materials and tools in compliance with the applicable occupational health and safety directives.

4.4.1 Signal cable A (type DS 300), construction

- Signal cable A is a double-shielded cable for signal transmission between the flow tube and transmitter.
- Bending radius: $\geq 50 \text{ mm} / 2''$

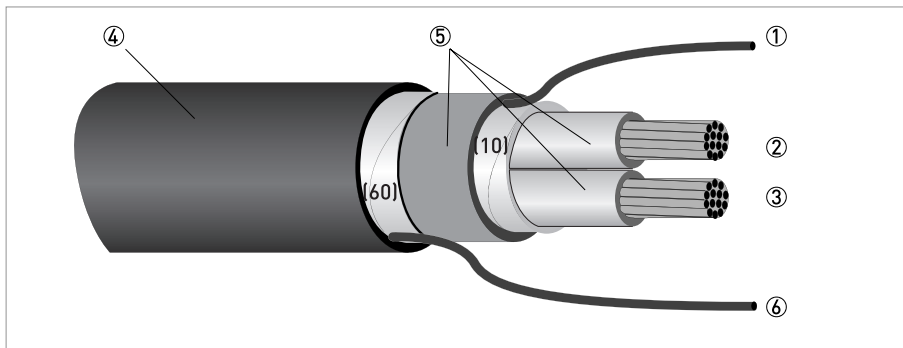

Figure 4-1: Construction of signal cable A

- ① Stranded drain wire (1) for the inner shield (10), $1.0 \text{ mm}^2 \text{ Cu}$ / AWG 17 (not insulated, bare)
- ② Insulated wire (2), $0.5 \text{ mm}^2 \text{ Cu}$ / AWG 20
- ③ Insulated wire (3), $0.5 \text{ mm}^2 \text{ Cu}$ / AWG 20
- ④ Outer sheath
- ⑤ Insulation layers
- ⑥ Stranded drain wire (6) for the outer shield (60)

4.4.2 Preparing signal cable A, connection to transmitter

**NOTICE!**

Assembly materials and tools are not part of the delivery. Use the assembly materials and tools in compliance with the applicable occupational health and safety directives.

- Connection of the two shields in the transmitter is carried out via the stranded drain wires.
- Bending radius: $\geq 50 \text{ mm} / 2''$

Required materials

- PVC insulating tube, $\varnothing 2.5 \text{ mm} / 0.1''$
- Heat-shrinkable tubing
- 2 wire end ferrules to DIN 46228: E 1.5-8 for the stranded drain wires (1, 6)
- 2 wire end ferrules to DIN 46228: E 0.5-8 for the insulated conductors (2, 3)

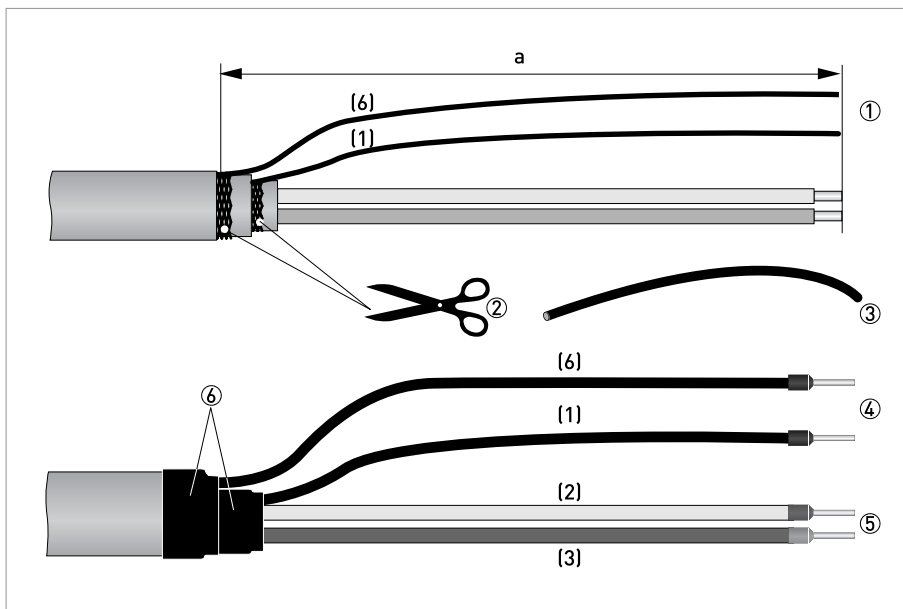

Figure 4-2: Preparation of signal cable A

$a = 80 \text{ mm} / 3.15''$



- ① Strip the conductor to dimension a .
- ② Cut off the inner shield (10) and the outer shield (60). Make sure not to damage the stranded drain wires (1, 6).
- ③ Slide the insulating tubes over the stranded drain wires (1, 6).
- ④ Crimp the wire end ferrules onto the stranded drain wire.
- ⑤ Crimp the wire end ferrules onto the conductors (2, 3).
- ⑥ Pull the heat-shrinkable tubing over the prepared signal cable.

4.4.3 Length of signal cable A



NOTICE!

For temperatures of the medium above 150°C / 300°F, a special signal cable and a ZD intermediate socket are necessary. These are available including the changed electrical connection diagrams.

Flow tube	Nominal size		Min. electrical conductivity [µS/cm]	Curve for signal cable A
	DN [mm]	[inch]		
8400A	10...150	3/8...6	20	A1
8500A	2.5...100	1/10...4	20	A1
9500A	25...150	1...6	20	A1
	200...1200	8...48	20	A2
9600A	10...150	3/8...6	20	A1
9700A	10...150	3/8...6	20	A1
	200...1200	8...48	20	A2

Table 4-1: Length of signal cable A

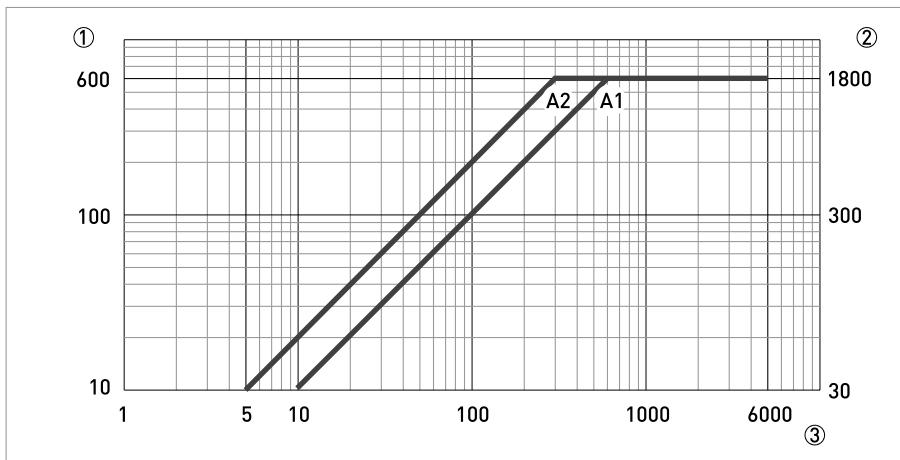

Figure 4-3: Maximum length of signal cable A

- ① Maximum length of signal cable A between the flow tube and transmitter [m]
- ② Maximum length of signal cable A between the flow tube and transmitter [ft]
- ③ Electrical conductivity of the medium being measured [µS/cm]

4.4.4 Preparing field current cable C, connection to transmitter

**DANGER!**

A shielded 2-wire copper cable is used as the field current cable. The shielding **MUST** be connected in the housing of the flow tube and transmitter.

**NOTICE!**

Assembly materials and tools are not part of the delivery. Use the assembly materials and tools in compliance with the applicable occupational health and safety directives.

- Field current cable C is not part of the scope of delivery.
- Bending radius: ≥ 50 mm / 2"

Required materials:

- Shielded, at least 2-wire copper cable with suitable heat-shrinkable tubing
- Insulating tube, size according to the cable being used
- Wire end ferrules to DIN 46228: size according to the cable being used

Length		Cross-section A_F (Cu)	
[m]	[ft]	[mm ²]	[AWG]
0...150	0...492	2 x 0.75 Cu ①	2 x 18
150...300	492...984	2 x 1.5 Cu ①	2 x 14
300...600	984...1968	2 x 2.5 Cu ①	2 x 12

Table 4-2: Length and cross-section of field current cable C

① Cu = copper cross-section

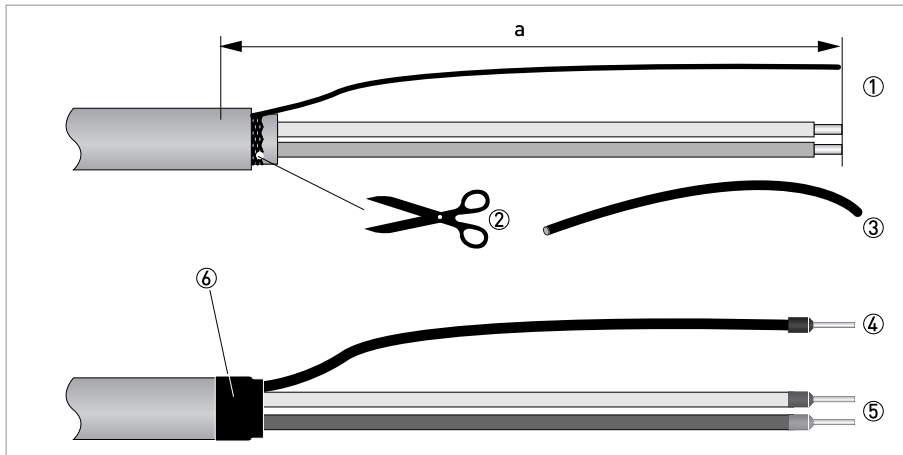

Figure 4-4: Field current cable C, preparation for the transmitter

$a = 80 \text{ mm} / 3.15''$



- ① Strip the conductor to dimension a.
- ② If a stranded drain wire is present, remove the shield that is present. Make sure not to damage the stranded drain wire.
- ③ Slide an insulating tube over the stranded drain wire.
- ④ Crimp a wire end ferrule onto the stranded drain wire.
- ⑤ Crimp the wire end ferrules on the conductors.
- ⑥ Pull a shrinkable tube over the prepared cable.

4.4.5 Preparing signal cable A, connection to flow tube

**NOTICE!**

Assembly materials and tools are not part of the delivery. Use the assembly materials and tools in compliance with the applicable occupational health and safety directives.

- The outer shield (60) is connected in the terminal compartment of the flow tube directly via the shield and a clip.
- Bending radius: $\geq 50 \text{ mm} / 2''$

Required materials

- PVC insulating tube, $\varnothing 2.0 \dots 2.5 \text{ mm} / 0.08 \dots 0.1''$
- Heat-shrinkable tubing
- Wire end ferrule to DIN 46228: E 1.5-8 for the stranded drain wire (1)
- 2 wire end ferrules to DIN 46228: E 0.5-8 for the insulated conductors (2, 3)

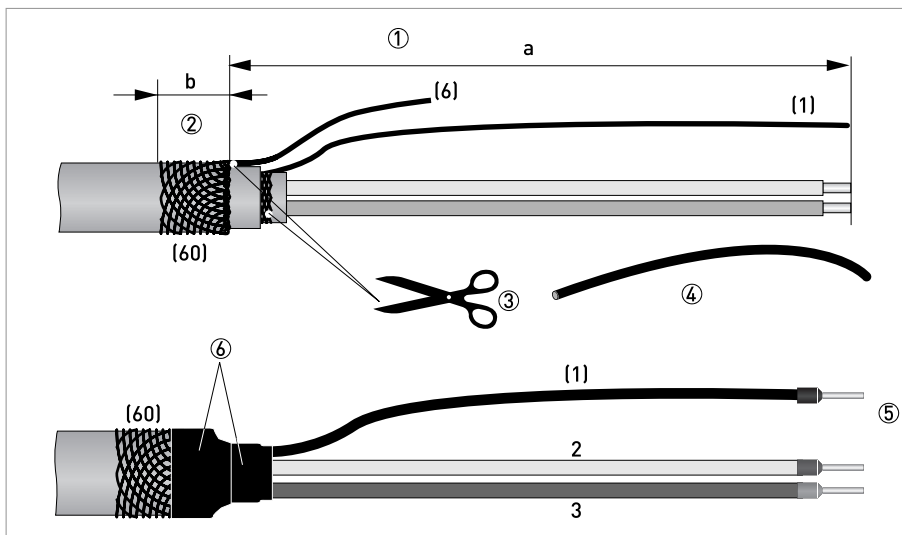

Figure 4-5: Preparing signal cable A, connection to flow tube

$a = 50 \text{ mm} / 2''$

$b = 10 \text{ mm} / 0.4''$



- ① Strip the conductor to dimension a.
- ② Trim the outer shield (60) to dimension b and pull it over the outer sheath.
- ③ Remove the stranded drain wire (6) of the outer shield and the inner shield. Make sure not to damage the stranded drain wire (1) of the inner shield.
- ④ Slide an insulating tube over the stranded drain wire (1).
- ⑤ Crimp the wire end ferrules onto conductors 2 and 3 and the stranded drain wire (1).
- ⑥ Pull the heat-shrinkable tubing over the prepared signal cable.

4.4.6 Preparing field current cable C, connection to flow tube



NOTICE!

Assembly materials and tools are not part of the delivery. Use the assembly materials and tools in compliance with the applicable occupational health and safety directives.

- The field current cable is not part of the scope of delivery.
- The shield is connected in the terminal compartment of the flow tube directly via the shield and a clip.
- Bending radius: $\geq 50 \text{ mm} / 2''$

Required materials

- Shielded 2-wire insulated copper cable
- Insulating tube, size according to the cable being used
- Heat-shrinkable tubing
- Wire end ferrules to DIN 46228: size according to the cable being used

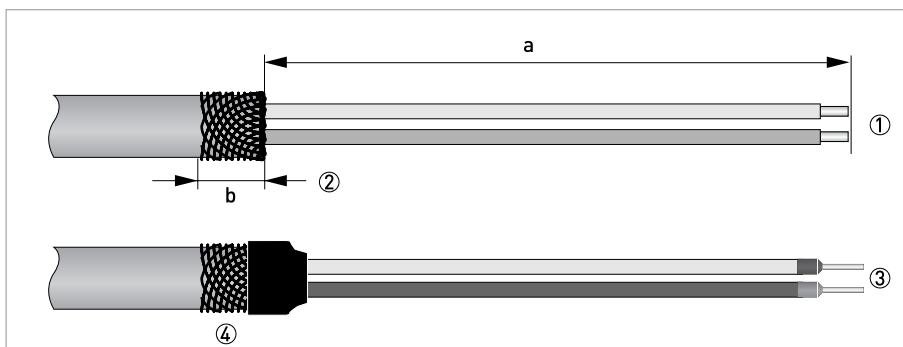

Figure 4-6: Preparation of field current cable C

a = 50 mm / 2"

b = 10 mm / 0.4"



- ① Strip the conductor to dimension a.
- ② Trim the outer shield to dimension b and pull it over the outer sheath.
- ③ Crimp wire end ferrules onto both conductors.
- ④ Pull a shrinkable tube over the prepared cable.

4.5 Connecting the signal and field current cables

**DANGER!**

Cables may only be connected when the power is switched off.

**DANGER!**

The device must be grounded in accordance with regulations in order to protect personnel against electric shocks.

**WARNING!**

*Observe without fail the local occupational health and safety regulations.
Any work done on the electrical components of the measuring device may only be carried out by properly trained specialists.*

4.5.1 Connecting the signal and field current cables to the transmitter, remote version



NOTICE!

The compact version is supplied pre-assembled from the factory.



Connect the electrical conductors as follows:

- ① Press with a screwdriver in the slot on the spring terminal.
- ② Insert the electrical conductor into the plug.
- ③ The conductor will be clamped as soon as the screwdriver is pulled out of the slot.

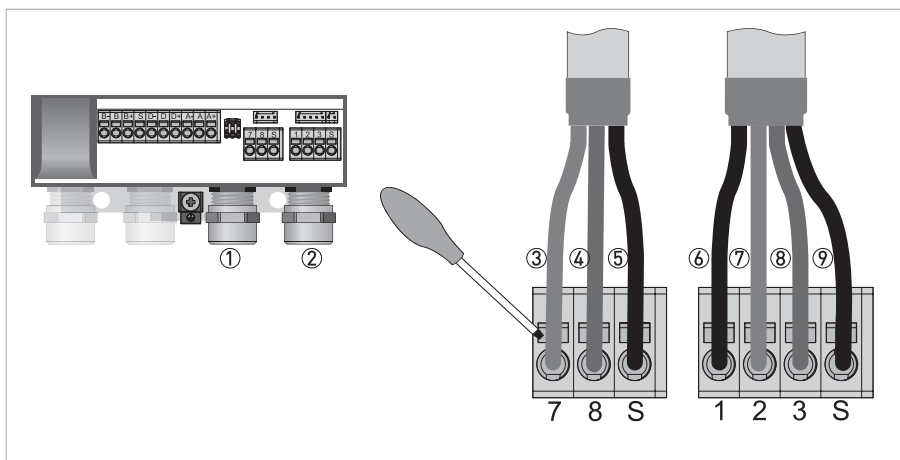

Figure 4-7: Connecting the signal and field current cables

- ① Cable entry for field current cable
- ② Cable entry for signal cable
- ③ Electrical conductor (7)
- ④ Electrical conductor (8)
- ⑤ Connecting the field current cable shield
- ⑥ Stranded drain wire (1) of the inner shield (10) of the signal cable
- ⑦ Electrical conductor (2)
- ⑧ Electrical conductor (3)
- ⑨ Stranded drain wire (S) of the outer shield (60)

4.5.2 Connection diagram for signal and field current cable

**DANGER!**

The device must be grounded in accordance with regulations in order to protect personnel against electric shocks.

- A shielded 2-wire copper cable is used as the field current cable. The shielding **MUST** be connected in the housing of the flow tube and transmitter.
- The outer shield (60) is connected in the terminal compartment of the flow tube directly via the shield and a clip.
- Bending radius of signal and field current cable: $\geq 50 \text{ mm} / 2''$
- The following illustration is schematic. The positions of the electrical connection terminals may vary depending on the housing version.

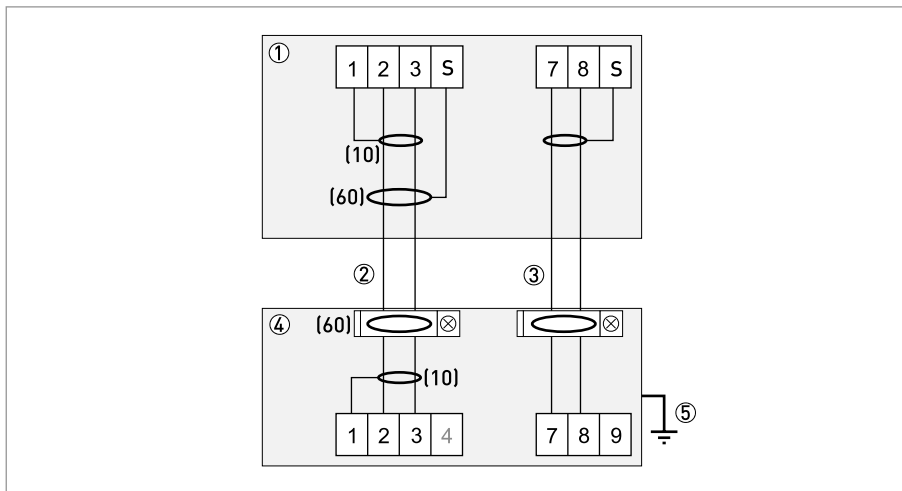

Figure 4-8: Connection diagram for signal and field current cable

- ① Electrical terminal compartment in the transmitter
- ② Signal cable A
- ③ Field current cable C
- ④ Electrical terminal compartment in the flow tube
- ⑤ Functional ground FE

4.6 Grounding the flow tube

**CAUTION!**

There should be no difference in potential between the flow tube and the housing or protective earth of the transmitter!

- The flow tube must be properly grounded.
- The grounding cable should not transmit any interference voltages.
- Do not use the grounding cable to connect any other electrical devices to ground at the same time.
- The flow tubes are connected to ground by means of a functional grounding conductor FE.
- Special grounding instructions for the various flow tubes are provided in the separate documentation for the flow tube.
- The documentation for the flow tube also contain descriptions on how to use grounding rings and how to install the flow tube in metal or plastic pipes or in pipes which are coated on the inside.

4.7 Connecting the power supply

**DANGER!**

- *To protect operators from electrical shock, during installation the cable for the power supply **must** be run with sheathing insulation up to the mains cover. The insulated individual wires have to be only below the mains cover!*
- *If there is no mains cover or if it has been lost, the 100...230 VAC device may only be operated from the outside (with a magnet pencil) while closed!*

- The housings of the devices, which are designed to protect the electronic equipment from dust and moisture, should be kept well closed at all times. Creepage distances and clearances are dimensioned to VDE 0110 and IEC 60664 for pollution severity 2. Supply circuits are designed for overvoltage category III and the output circuits for overvoltage category II.
- Fuse protection ($I_N \leq 16 \text{ A}$) for the infeed power circuit, and also a separator (switch, circuit breaker) to isolate the transmitter must be provided.

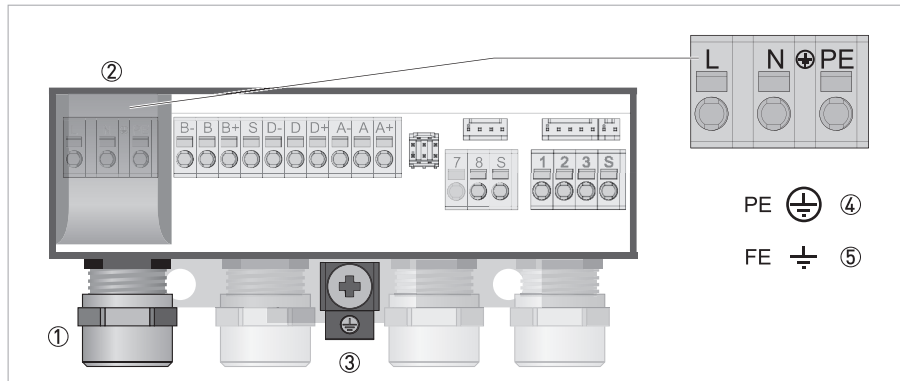

Figure 4-9: Terminal compartment for power

- ① Cable entry for power supply
- ② Mains cover
- ③ Ground terminal
- ④ 100...230 VAC [-15% / +10%]
- ⑤ 24 VDC [-30% / +30%]



- To open the cover of the electrical terminal compartment, lightly press in the side walls of the mains cover ②.
- Flip the mains cover up.
- Connect the power supply.
- Close the mains cover again by flipping it down.

100...230 VAC (tolerance range: -15% / +10%)

- Note the power supply voltage and frequency [50...60 Hz] on the nameplate.



NOTICE!

240 VAC + 5% is included in the tolerance range.

24 VDC (tolerance range: -30% / +30%)

- Note the data on the nameplate!
- When connecting to functional extra-low voltages, provide a facility for protective separation (PELV) [acc. to VDE 0100 / VDE 0106 and/or IEC 60364 / IEC 61140 or relevant national regulations].

4.8 Inputs and outputs, overview

4.8.1 Description of the CG number

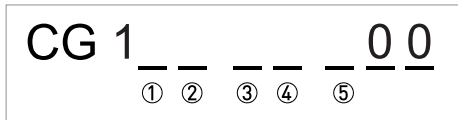

Figure 4-10: Marking (CG number) of the electronics module and output variants

- ① ID number: 0
- ② ID number: 0 = standard; 9 = special
- ③ Power supply
- ④ Display (language versions)
- ⑤ Output version

4.8.2 Fixed, non-alterable output versions

This transmitter is available with various output combinations.

- The grey boxes in the tables denote unassigned or unused connection terminals.
- In the table, only the final digits of the CG no. are depicted.
- Terminals D- and A- are connected for active pulse/frequency output (no galvanic isolation anymore).
- Available are an active or passive pulse/frequency output, or the active or passive status/limit output. It's not possible to use both at the same time!

CG no.	Connection terminals							
	S	D-	D	D+	A-	A	A+	
1 0 0 R 0 0	①	P _p / S _p passive				I _p + HART® passive ②		
		connected to A-	P _a active			connected to D-	I _a + HART® active ②	
		P _p / S _p passive					I _a + HART® active ②	

Table 4-3: Basic outputs (I/Os)

- ① Shielding
- ② Function changed by reconnecting

CG no.	Connection terminals			
	B-	B	B+	S
R 0 0	Sign. A (D0-)	Common	Sign. B (D1+)	Shielding

Table 4-4: Modbus (I/O) (option)

I_a	I_p	Current output active or passive
P_a	P_p	Pulse/frequency output active or passive
S_a	S_p	Status output/limit switch active or passive

Table 4-5: Description of used abbreviations

4.9 Description of the inputs and outputs

4.9.1 Current output



NOTICE!

Depending on the version, the outputs must be connected passively or actively!

- All outputs are electrically isolated from each other and from all other circuits.
- All operating data and functions can be adjusted.
- Passive mode: external power $U_{ext} \leq 32$ VDC at $I \leq 22$ mA
- Active mode: load impedance $R_L \leq 750 \Omega$ at $I \leq 22$ mA
- Self-monitoring: interruption or load impedance too high in the current output loop
- Error message possible via status output, error indication on LC display.
- Current value error detection can be adjusted.
- Automatic range conversion via threshold. The setting range for the threshold is between 5 and 80% of $Q_{100\%}$, $\pm 0...5\%$ hysteresis (corresponding ratio from smaller to larger range of 1:20 to 1:1.25).
Signaling of the active range possible via a status output (adjustable).
- Forward / reverse flow measurement (F/R mode) is possible.



NOTICE!

For further information refer to Connection diagrams of outputs on page 38 and refer to Technical data on page 77.

4.9.2 Pulse output and frequency output



NOTICE!

Depending on the version, the outputs must be connected passively or actively!

- All outputs are electrically isolated from each other and from all other circuits.
- All operating data and functions can be adjusted.
- Passive mode:
External power supply required: $U_{\text{ext}} \leq 32 \text{ VDC}$
 $I \leq 100 \text{ mA}$ at $f \leq 10 \text{ kHz}$ (over range up to $f_{\text{max}} \leq 12 \text{ kHz}$)
- Active mode:
Use of the internal power supply: $U_{\text{nom}} = 20 \text{ VDC}$
 $I_{\text{Peak}} < 100 \text{ mA}$
 $I_{\text{Average}} \leq 10 \text{ mA}$ at $f \leq 10 \text{ kHz}$ (over range up to $f_{\text{max}} \leq 10 \text{ kHz}$)
- Scaling:
Frequency output: in pulses per time unit (e.g. 1000 pulses/s at $Q_{100\%}$);
Pulse output: quantity per pulse.
- Pulse width:
symmetric (pulse duty factor 1:1, independent of output frequency)
automatic (with fixed pulse width, duty factor approx. 1:1 at $Q_{100\%}$) or
fixed (pulse width adjustable as required from 0.05 ms...2 s)
- Forward / reverse flow measurement (F/R mode) is possible.
- The pulse and frequency output can also be used as a status output / limit switch.



NOTICE!

For further information refer to Connection diagrams of outputs on page 38 and refer to Technical data on page 77.

4.9.3 Status output and limit switch

**NOTICE!**

Depending on the version, the outputs must be connected passively or actively!

- The status outputs / limit switches are electrically isolated from each other and from all other circuits.
- The output stages of the status outputs/limit switches during simple active or passive operation behave like relay contacts and can be connected with any polarity.
- All operating data and functions can be adjusted.
- Passive mode:
External power supply required: $U_{\text{ext}} \leq 32 \text{ VDC}$; $I \leq 100 \text{ mA}$
- Active mode:
Use of the internal power supply: $U_{\text{nom}} = 20 \text{ VDC}$; $I \leq 20 \text{ mA}$
- For information on the adjustable operating states refer to *Function tables* on page 55.

**NOTICE!**

For further information refer to Connection diagrams of outputs on page 38 and refer to Technical data on page 77.

4.10 Electrical connection of the outputs



NOTICE!

Assembly materials and tools are not part of the delivery. Use the assembly materials and tools in compliance with the applicable occupational health and safety directives.

4.10.1 Electrical connection of the outputs



DANGER!

All work on the electrical connections may only be carried out with the power disconnected. Take note of the voltage data on the nameplate!

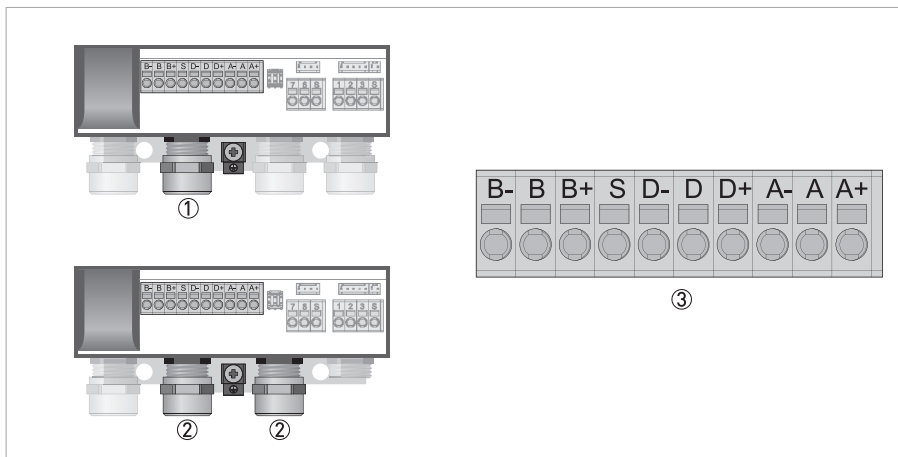

Figure 4-11: Electrical connection of the outputs

- ① Cable entry, remote version
- ② Cable entry, compact version (right cable entry is optional)
- ③ Terminal block for the connection of outputs



- Open the housing cover
- Push the prepared cables through the cable entries and connect the necessary conductors.
- Connect the shield.
- Close the housing cover.



NOTICE!

Ensure that the housing gasket is properly fitted, clean and undamaged.

4.10.2 Laying electrical cables correctly

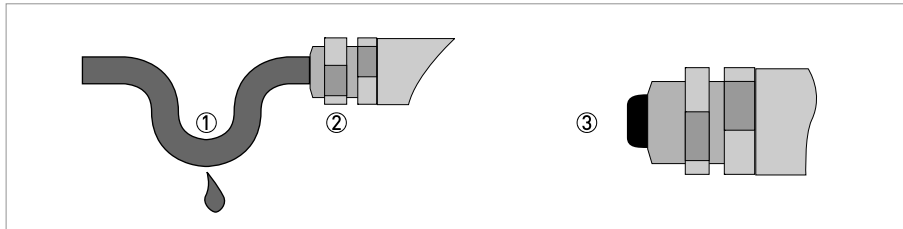

Figure 4-12: Protect housing from dust and water



- ① For compact versions with nearly horizontally-oriented cable entries, lay the necessary electric cables with a drip loop as shown in the illustration.
- ② Tighten the screw connection of the cable entry securely.
- ③ Seal cable entries that are not needed with a plug.

4.11 Connection diagrams of outputs

4.11.1 Important notes

**NOTICE!**

Depending on the version, the outputs must be connected passively or actively!

- All groups are electrically isolated from each other and from all other output circuits.
- Passive mode: An external power supply is necessary to operate (activation) the subsequent devices (U_{ext}).
- Active mode: The transmitter supplies the power for operation (activation) of the subsequent devices, observe max. operating data.
- Terminals that are not used should not have any conductive connection to other electrically conductive parts.

I_a	I_p	Current output active or passive
P_a	P_p	Pulse/frequency output active or passive
S_a	S_p	Status output/limit switch active or passive

Table 4-6: Description of used abbreviations

4.11.2 Description of the electrical symbols





	<p>mA meter 0...20 mA or 4...20 mA and other R_L is the internal resistance of the measuring point including the cable resistance</p>
	<p>DC voltage source (U_{ext}), external power supply, any connection polarity</p>
	<p>DC voltage source (U_{ext}), observe connection polarity according to connection diagrams</p>
	<p>Internal DC voltage source</p>
	<p>Controlled internal power source in the device</p>
	<p>Electronic or electromagnetic counter At frequencies above 100 Hz, shielded cables must be used to connect the counters. R_i Internal resistance of the counter</p>
	<p>Button, N/O contact or similar</p>

Table 4-7: Description of the electrical symbols

4.11.3 Basic and Modbus outputs

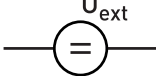
**CAUTION!**

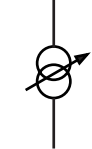
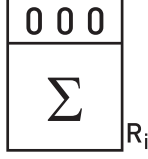
Observe connection polarity.

**NOTICE!**

For further information refer to *Description of the inputs and outputs on page 34* and refer to *HART connection on page 45*.

Current output active (HART®)

- $U_{\text{int, nom}} = 20 \text{ VDC}$
- $I \leq 22 \text{ mA}$
- $R_L \leq 750 \Omega$
- HART® at connection terminals A

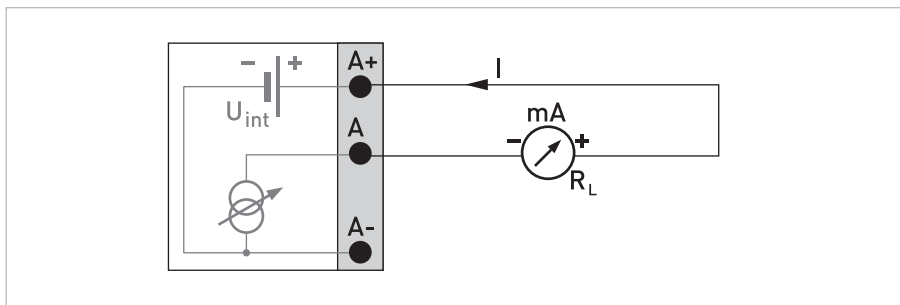

Figure 4-13: Current output active I_a

Current output passive (HART®)

- $U_{\text{ext}} \leq 32 \text{ VDC}$
- $I \leq 22 \text{ mA}$
- $U_0 \leq 2 \text{ V}$ at $I = 22 \text{ mA}$
- $R_{L, \text{max}} = (U_{\text{ext}} - U_0) / I_{\text{max}}$
- HART® at connection terminals A

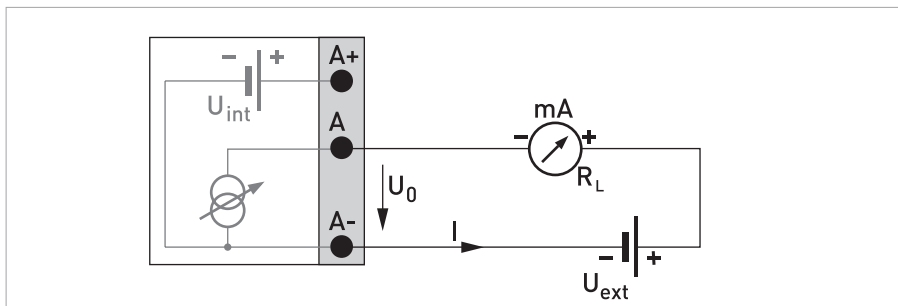

Figure 4-14: Current output passive I_p

**NOTICE!**

- For frequencies above 100 Hz, shielded cables are to be used in order to reduce effects from electrical interferences (EMC).
- Shielding takes place at the electrical connection (S) of the output terminal block.

**NOTICE!**

- Independent of connection polarity.
- The output is open if the transmitter is not powered.

Pulse/frequency output passive

- $U_{\text{ext}} \leq 32 \text{ VDC}$
- f_{max} in the operating menu set to $f_{\text{max}} \leq 100 \text{ Hz}$:
 $I \leq 100 \text{ mA}$
 $R_L \leq 47 \text{ k}\Omega$
 closed:
 $U_0 \leq 0.2 \text{ V}$ at $I = 10 \text{ mA}$
 $U_0 \leq 2 \text{ V}$ at $I = 100 \text{ mA}$
 open:
 $I \leq 0.05 \text{ mA}$ at $U_{\text{ext}} = 32 \text{ V}$
- f_{max} in operating menu set to $100 \text{ Hz} < f_{\text{max}} \leq 10 \text{ kHz}$:
 (over range up to $f_{\text{max}} \leq 12 \text{ kHz}$)
 $I \leq 20 \text{ mA}$
 $R_L \leq 10 \text{ k}\Omega$ for $f \leq 1 \text{ kHz}$
 $R_L \leq 1 \text{ k}\Omega$ for $f \leq 10 \text{ kHz}$
 closed:
 $U_0 \leq 1.5 \text{ V}$ at $I = 1 \text{ mA}$
 $U_0 \leq 2.5 \text{ V}$ at $I = 10 \text{ mA}$
 $U_0 \leq 5 \text{ V}$ at $I = 20 \text{ mA}$
 open:
 $I \leq 0.05 \text{ mA}$ at $U_{\text{ext}} = 32 \text{ V}$
 Use shielded cables!
- The minimum load impedance $R_{L, \text{min}}$ is calculated as follows:
 $R_{L, \text{min}} = (U_{\text{ext}} - U_0) / I_{\text{max}}$
- Can also be set as status output; for the electrical connection refer to status output connection diagram.

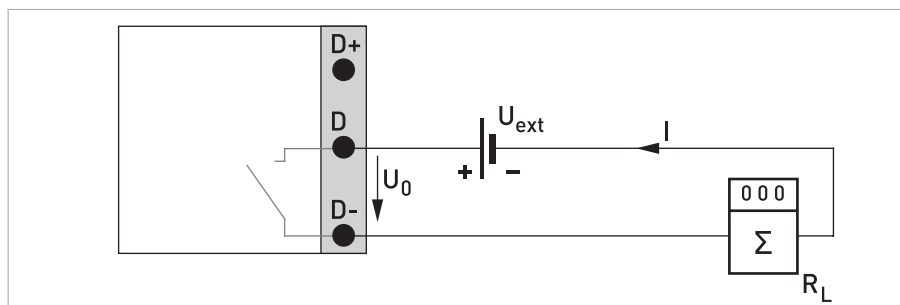
Figure 4-15: Pulse/frequency output passive P_p

**NOTICE!**

- The active output is galvanically coupled with the current output.
- This output is intended to drive mechanical or electronic counters directly.

Pulse/frequency output active

- $U_{\text{int, nom}} \leq 20 \text{ V}$
- $R_V = 1 \text{ k}\Omega$
- $C = 1000 \text{ }\mu\text{F}$
- **High current mechanical counter**
 $f_{\text{max}} \leq 1 \text{ Hz}$
- **Low current mechanical counter**
 $I \leq 20 \text{ mA}$
 $R_L \leq 10 \text{ k}\Omega$ for $f \leq 1 \text{ kHz}$
 $R_L \leq 1 \text{ k}\Omega$ for $f \leq 10 \text{ kHz}$
closed:
 $U_0 \geq 12.5 \text{ V}$ at $I = 10 \text{ mA}$
open:
 $I \leq 0.05 \text{ mA}$ at $U_{\text{nom}} = 20 \text{ V}$

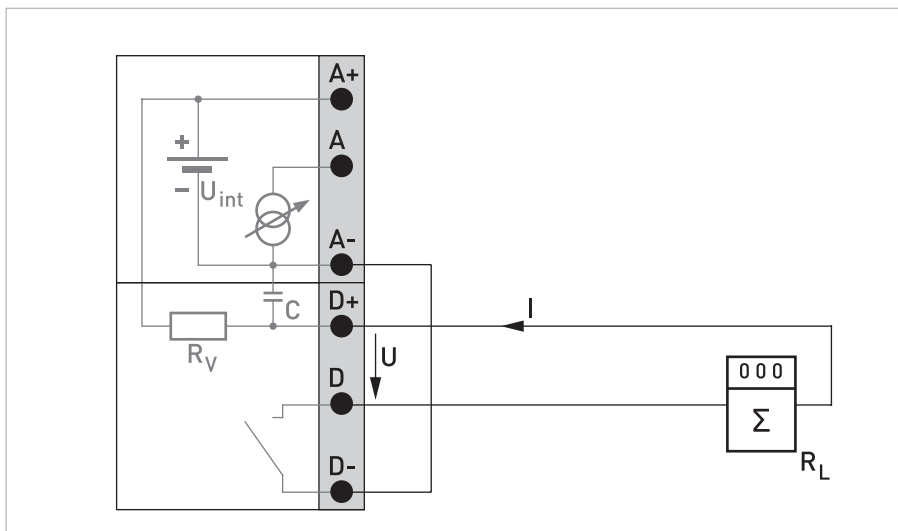
Figure 4-16: Pulse/frequency output active P_a

**NOTICE!**

- Independent of connection polarity.
- The output is open if the transmitter is not powered.

Status output / limit switch passive

- $U_{\text{ext}} \leq 32 \text{ VDC}$
- $I \leq 100 \text{ mA}$
- $R_L = 47 \text{ k}\Omega$
- closed:
 $U_0 \leq 0.2 \text{ V}$ at $I = 10 \text{ mA}$
 $U_0 \leq 2 \text{ V}$ at $I = 100 \text{ mA}$
- open:
 $I \leq 0.05 \text{ mA}$ at $U_{\text{ext}} = 32 \text{ V}$

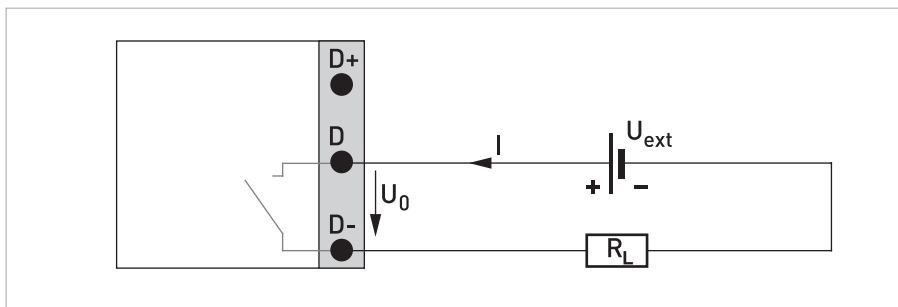
Figure 4-17: Status output / limit switch passive S_p

4.11.4 HART connection

**NOTICE!**

The current output always has HART[®] capability and is connected at connection terminals A+/A-/A.

All HART[®] connections (point-to-point and multi-drop operation) both work actively and passively.

Example for active HART[®] connection (point-to-point)

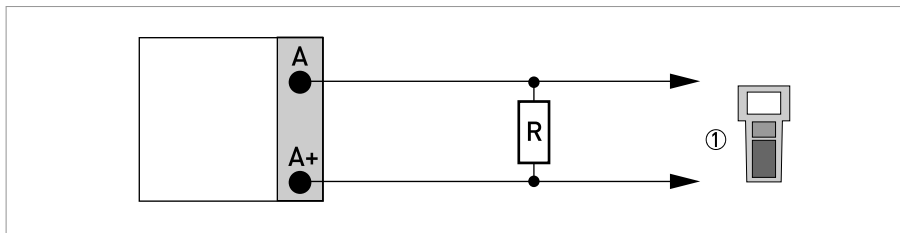

Figure 4-18: HART[®] connection active [I_a]

① HART[®] communicator

The parallel resistance to the HART[®] communicator must be $R \geq 230 \Omega$.

Example for passive HART[®] connection (multi-drop mode)

- $I: I_{0\%} \geq 4 \text{ mA}$
- Multi-drop mode $I: I_{\text{fix}} \geq 4 \text{ mA} = I_{0\%}$
- $U_{\text{ext}} \leq 32 \text{ VDC}$
- $R \geq 230 \Omega$

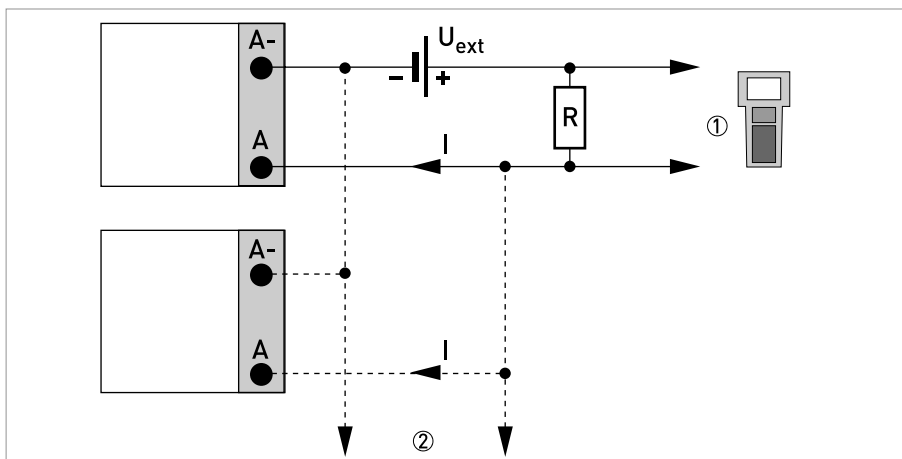

Figure 4-19: HART[®] connection passive [I_p]

- ① HART[®] communicator
- ② Other devices with HART[®] capability

5.1 Switching on the power

Before connecting to power, please check that the system has been correctly installed. This includes:

- The device must be mechanically safe and mounted in compliance with the regulations.
- Remove the magnet pencil and keep it on a save place (is only valid for the display version).
- The power connections must have been made in compliance with the regulations.
- The electrical terminal compartments must be secured and the covers have been screwed on.
- Check that the electrical operating data of the power supply are correct.



- Switching on the power.

5.2 Starting the transmitter

The measuring device, consisting of the flow tube and the transmitter, is supplied ready for operation. All operating data have been set at the factory in accordance with your order specifications.

When the power is switched on, a self test is carried out. After that the device immediately begins measuring, and the current values are displayed.

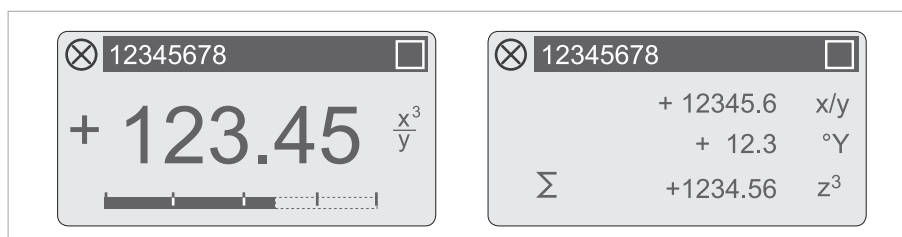

Figure 5-1: Displays in measuring mode (examples for 2 or 3 measured values)
x, y and z denote the units of the measured values displayed

It is possible to change between the two measured value windows, the trend display and the list with the status messages by pressing the keys \uparrow and \downarrow . For information about possible status messages, their meaning and cause refer to *Status messages and diagnostic information* on page 69.

6.1 Safety instructions for the use of the magnet pencil

To operate the transmitter when the housing is closed, 4 magnetic keys are available. They are activated by a magnet pencil.



WARNING!

The magnet pencils can be dangerous for people with cardiac pacemakers or other metal implants. Make sure that these people do not use the magnet pencil or meet minimum clearances! Observe the relevant national and local regulations and requirements!

6.2 Display and operating elements

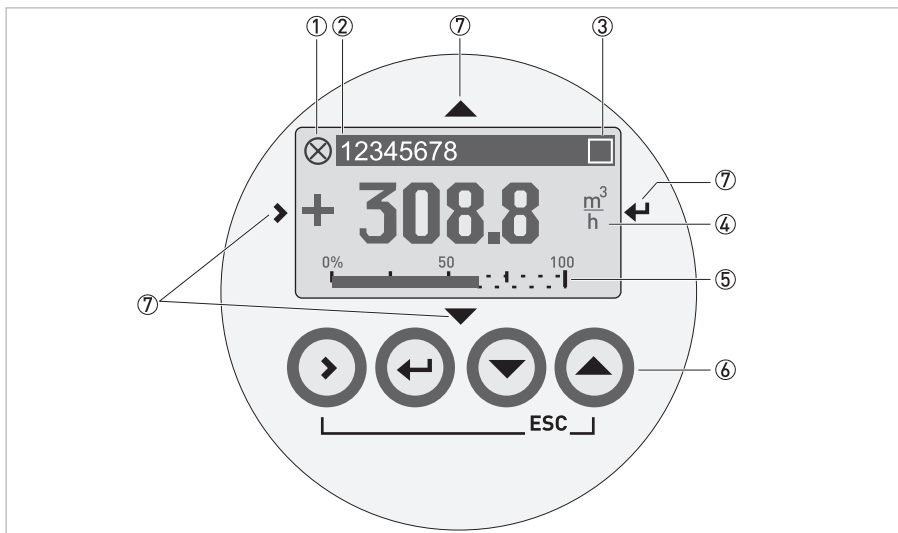

Figure 6-1: Display and operating elements (Example: flow indication with 2 measuring values)

- ① Indicates a possible status message in the status list
- ② Tag number (is only indicated if this number was entered previously by the operator)
- ③ Indicates when a key has been pressed
- ④ 1st measured variable in large representation
- ⑤ Bargraph indication
- ⑥ Push buttons for operation with open housing (see table below for function and representation in text)
- ⑦ Magnet keys for operation with closed housing (see table below for function and representation in text)



NOTICE!

- *After 5 minutes of inactivity, there is an automatic return to measuring mode. Previously changed data is not saved.*

Key	Measuring mode	Menu mode	Submenu or function mode	Parameter and data mode
>	Switch from measuring mode to menu mode; press key for 2.5 s, "A quick setup" menu is then displayed	Access to displayed menu, then 1st submenu is displayed	Access to displayed submenu or function	For numerical values, move cursor one position to the right
↵	Reset of display	Return to measuring mode but prompt whether the data should be saved	Press 1 to 3 times, return to menu mode, data saved	Return to submenu or function, data saved
↓ or ↑	Switch between display pages: measured value 1 + 2, trend page and status page	Select menu	Select submenu or function	Use highlighted cursor to change number, unit, property and to move the decimal point
Esc (> + ↑)	-	-	Return to menu mode without acceptance of data	Return to submenu or function without acceptance of data

Table 6-1: Description of key functionality

6.2.1 Display in measuring mode with 2 or 3 measured values

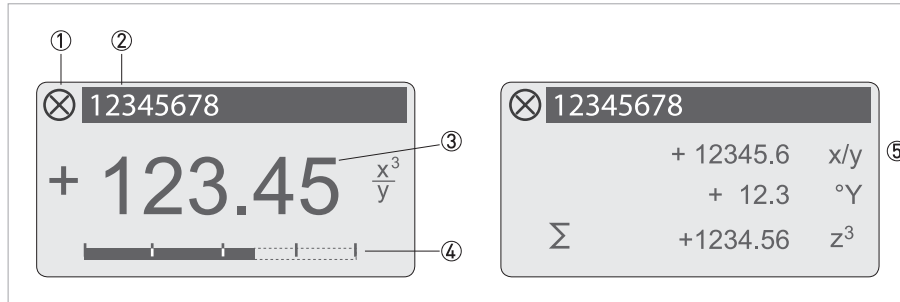

Figure 6-2: Example for display in measuring mode with 2 or 3 measured values

- ① Indicates a possible status message in the status list
- ② Tag number (is only indicated if this number was entered previously by the operator)
- ③ 1st measured variable in large representation
- ④ Bargraph indication
- ⑤ Depiction with 3 measured values

6.2.2 Display for selection of submenu and functions, 3 lines

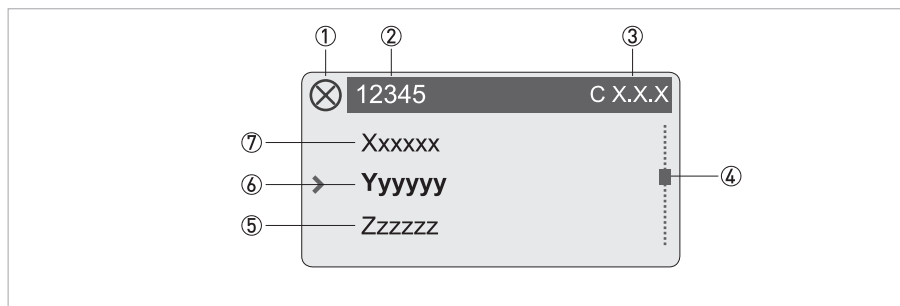

Figure 6-3: Display for selection of submenu and functions, 3 lines

- ① Indicates a possible status message in the status list
- ② Menu, submenu or function name
- ③ Number relating to ⑥
- ④ Indicates position within menu, submenu or function list
- ⑤ Next menu(s), submenu or function
[__ _ signals in this line the end of the list]
- ⑥ Current menu(s), submenu or function
- ⑦ Previous menu(s), submenu or function
[__ _ signals in this line the beginning of the list]

6.2.3 Display when setting parameters, 4 lines

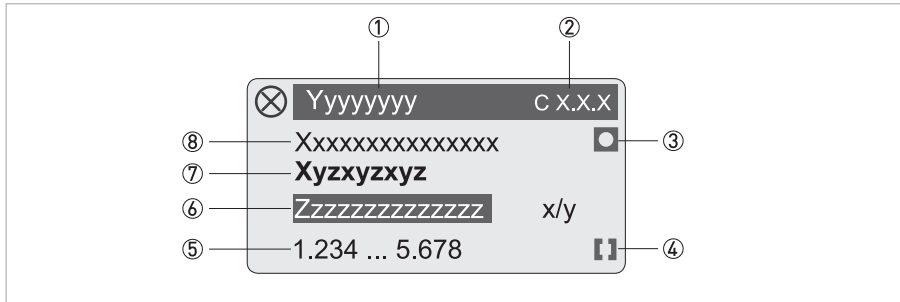

Figure 6-4: Display when setting parameters, 4 lines

- ① Current menu(s), submenu or function
- ② Number relating to ⑦
- ③ Denotes factory setting
- ④ Denotes permissible value range
- ⑤ Permissible value range for numeric values
- ⑥ Currently set value, unit or function (when selected, appears with white text, blue background)
This is where the data is changed.
- ⑦ Current parameter
- ⑧ Factory setting of parameter

6.2.4 Display when previewing parameters, 4 lines

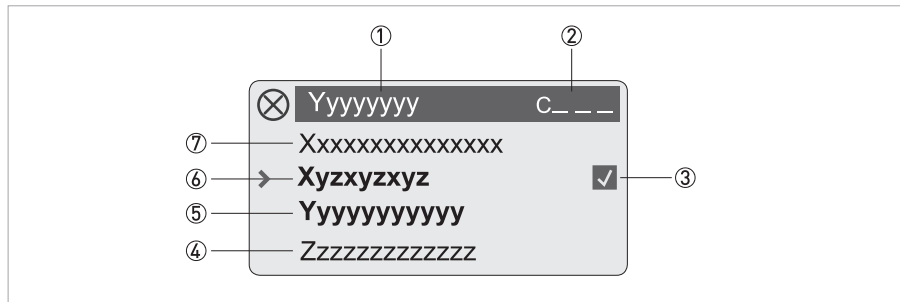

Figure 6-5: Display when previewing parameters, 4 lines

- ① Current menu(s), submenu or function
- ② Number relating to ⑥
- ③ Denotes a changed parameter (simple check of changed data when browsing through lists)
- ④ Next parameter
- ⑤ Currently set data from ⑥
- ⑥ Current parameter (for selection press key >; then see previous chapter)
- ⑦ Factory setting of parameter

6.3 Menu structure



NOTICE!

- The menu structure for the standard device is described.
- Special functions for Modbus are described in detail in the corresponding supplementary instructions.
- Note the key function within and between the columns.

Measuring mode	Select menu	Select menu and/or submenu	Select function and set data
←	Press > 2.5 s	↓ ↑	↓ ↑ >
	A quick setup	> ←	> ←
		A1 language	-
		A2 HART	A2.1 tag
		A3 RS 485 / Modbus	A3.1 tag A3.2 slave address
		A4 reset?	A4.1 reset errors A4.2 counter 1 A4.3 counter 2
		A5 analogue outputs	A5.1 range A5.2 time constant A5.3 low flow cutoff
		A6 digital outputs	A6.1 max. pulse rate A6.2 pulse value unit A6.3 value p. pulse
		A7 process input	A7.1 device serial no. A7.2 zero calibration A7.3 size A7.4 GKL A7.5 field frequency A7.6 flow direction
←	B test	> ←	> ←
		B1 simulation	For details about the submenus refer to <i>Menu "B test"</i> on page 57.
		B2 actual values	
		B3 information	
	↓ ↑	↓ ↑	↓ ↑ >

Table 6-2: Menu structure "A quick setup" and "B test"

Measuring mode		Select menu	Select menu and/or submenu	Select function and set data
		↓ ↑	↓ ↑	↓ ↑ >
←	Press > 2.5 s			
	C setup	> ←	C1 process input	> ←
			C1.1 calibration	
			C1.2 filter	
			C1.3 empty pipe detect	
			C1.4 information	
			C1.5 simulation	
←		> ←	C2 I/O (input/output)	> ←
			C2.1 hardware	
			C2.1 - ①	
			C2.1 current output A ①	
			C2.5 - ①	
			C2.5 frequency out D ①	
			C2.5 pulse output D ①	
			C2.5 status output D ①	
			C2.5 limit switch D ①	
←		> ←	C3 I/O counter	> ←
			C3.1 counter 1	
			C3.2 counter 2	
←		> ←	C4 HART	> ←
			C4.1 HART (on/off)	
			C4.2 address	
			C4.3 message	
			C4.4 description	
			C4.5 HART units	
←		> ←	C6 device	> ←
			C6.1 device info	
			C6.2 display	
			C6.3 1. meas. page	
			C6.4 2. meas. page	
			C6.5 graphic page	
			C6.6 special functions	
			C6.7 units	
			C6.8 quick setup	
		↓ ↑		↓ ↑ >

Table 6-3: Menu structure "C setup"

① Depending on settings in "C2.2 hardware"

6.4 Function tables



NOTICE!

- *The functions for the standard device are described in the following tables.*
- *Special functions for Modbus are described in detail in the corresponding supplementary instructions.*
- *Depending on the device version, not all functions are available.*

6.4.1 Menu "A quick setup"

Function	Setting / Description
----------	-----------------------

A1 language

A1 language	Language selection depends on the device version.
-------------	---

A2 HART

A2.1 tag	Measuring point identifier (Tag no.) appears in the LC display header (up to 8 digits).
----------	---

A3 RS485/Modbus

A3.1 tag	Measuring point identifier (Tag no.) appears in the LC display header (up to 16 digits). The first 8 digits are identical to the HART [®] measuring point (see above).
A3.2 slave address	Setting the device address at the Modbus interface.

A4 reset?

A4.1 reset errors	Query: reset errors? Select: no / yes
A4.2 counter 1	Query: reset counter? Select: no / yes (available if activated in C5.9.1)
A4.3 counter 2	Query: reset counter? Select: no / yes (available if activated in C5.9.2)

A5 analogue outputs

A5.1 range	Measuring range for the analogue outputs (current output, frequency output and display).
A5.2 time constant	Time constant for the analogue outputs (current output, frequency output and display).
A5.3 low flow cutoff	Low flow cutoff for the analogue outputs (current output and frequency output).

A6 digital outputs

A6.1 max. pulse rate	Setting the maximum pulse rate.
	Limit is 120% of this pulse rate.
A6.2 pulse value unit	Selection of the unit from a list, depending on the "measurement".
A6.3 value p. pulse	Setting for pulse output D (volume or mass value per pulse).
	Setting: xxx.xxx in L or kg or in the unit selected in A6.2

A7 process input

A7.1 device serial no.	Shows the serial number of the system (C5.1.3).
The following process input parameters are only available, if the quick access has been activated in the menu "setup / device / quick setup" (C6.8.3).	
A7.2 zero calibration	Display of actual zero calibration value.
	Query: calibrate zero?
	For settings refer to C1.1.1.
A7.3 size	Select from size table.
A7.4 GKL	Set value according to information on nameplate; range: 0.5...20
A7.5 field frequency	Setting as on flow tube nameplate = line frequency x value (from the following list): 1/2; 1/4; 1/6; 1/8; 1/12; 1/18; 1/36; 1/50
A7.6 flow direction	Define the polarity of the flow direction.
	Select: normal direction (according to the arrow on the flow tube) / reverse direction (in the opposite direction to the arrow)

Table 6-4: Menu "A quick setup"

6.4.2 Menu "B test"

Function	Setting / Description
B1 simulation	
B1.1 volume flow B1.1 mass flow	Depending on the selection, simulation of the volume or mass flow according to the following sequence: Select: set value / break (exit function without simulation)
	Query: start simulation? Select: no (exit function without simulation) / yes (start simulation)
B1.2 current output A	Simulation X [X stands for one of the connection terminals A or D] Sequence and settings similar to B1.2, see above! For the pulse output the set number of pulses are displayed once in a second!
B1.3 pulse output D	
B1.3 frequency out X	
B1.3 limit switch D	
B1.3 status output D	
B2 actual values	
B2.1 operating hours	Display the actual operating hours. Exit the displayed function with the ↵ key.
B2.2 act. flow speed	Display the actual flow speed. Exit the displayed function with the ↵ key.
B2.3 electr. temperature	Display the actual electronics temperature. Exit the displayed function with the ↵ key.
B2.4 act. coil resistance	Display the actual resistance of the field coils.
B3 information	
B3.1 C number	This number clearly identifies the electronics.
B3.2 Electronic Revision ER	Reference identification number, electronic revision and production date of the device; includes all hardware and software changes
B3.3 device serial no.	Serial number of the system.
B3.4 electronic serial no.	Serial number of the electronics.

Table 6-5: Menu "B test"

6.4.3 Menu "C setup"

Function	Setting / Description
----------	-----------------------

C1 process input

C1.1 calibration

C1.1.1 zero calibration	Display of actual zero calibration value. Query: calibrate zero? Select: break (return with ← key) / standard (factory setting) / manual (display last value, set new value, range: -1.00...+1 m/s) / automatic (shows the current value as the new zero calibration value)
C1.1.2 size	Select from size table.
C1.1.3 GKL	Set value acc. to the information on the nameplate. Range: 0.5...20
C1.1.4 measurement	Select: volume flow (default setting) / mass flow (using the fixed density, the volume flow is converted into mass flow)
C1.1.5 range	Measuring range for the analogue outputs (current output, frequency output and display). Range: 0.0...100%
C1.1.6 density	For calculating the mass flow from the volume flow. Range: 0.1...5 kg/L
C1.1.7 target conduct.	Reference value for on-site calibration. Range: 1.000...50000 µS/cm
C1.1.8 EF electr. factor	For calculation of the conductivity based on the electrode impedance. Query: calibrate EF? Select: break (return with ← key) / standard (with factory setting) / manual (set desired value) / automatic (determines EF according to the setting in C1.1.10)
C1.1.9 field frequency	Setting as on flow tube nameplate = line frequency x value (from the following list): 1/2; 1/4; 1/6; 1/8; 1/12; 1/18; 1/36; 1/50
C1.1.10 select settling	Select settling (special function). Select: standard (fixed allocation) / manual (manual time setting for the settling time for the field current)
C1.1.11 settling time	Only available if "manual" is selected in C1.1.10. Range: 1.0...250 ms
C1.1.12 line frequency	Setting the line frequency. Select: 50 Hz or 60 Hz
C1.1.13 act. coil resistance	Display of the actual resistance of the field coil.

C1.2 filter

C1.2.1 limitation	Limitation of all flow values, before smoothing by time constant, affects all outputs.
	Settings: -xxx.x / +xxx.x m/s; condition: 1st value < 2nd value
	Range 1st value: -100.0 m/s ≤ value ≤ -0.001 m/s
	Range 2nd value: +0.001 m/s ≤ value ≤ +100 m/s
C1.2.2 flow direction	Define the polarity of the flow direction.
	Select: normal direction (according to the arrow on the flow tube) / reverse direction (in the opposite direction to the arrow)
C1.2.3 time constant	Time constant of all flow measurements.
	xxx.x s; range: 0.0...100 s
C1.2.4 pulse filter	Suppresses noise due to solids, air/gas bubbles and sudden changes in pH.
	Select: off (without pulse filter) / on (with pulse filter) / automatic (with new pulse filter)
	Pulse filter "on": The change from one measurement value to the next one is limited to the value "pulse limitation" for the total time "pulse width". This filter allows a faster signal tracking for slowly changing flow values.
	Pulse filter "automatic": The raw flow values are collected into a buffer, covering two times the "pulse width" values. This filter is called "median" filter. This filter allows a better suppression of pulse shaped disturbances (particles or air bubbles in very noisy environment).
C1.2.5 pulse width	Length of interference and delays to be suppressed on sudden changes in flow.
	Only available, if pulse filter (C1.2.4) is "on" or "automatic".
	xx.x s; range for "on": 0.01...10 s or for "automatic": 0.1...20 s
C1.2.6 pulse limitation	Dynamic limitation from one measured value to the next; only if pulse filter (C1.2.4) is "on".
	xx.x s; range: 0.01...100 m/s
C1.2.7 low flow cutoff	Sets low flow values to "0"; affects all outputs
	x.xxx ± x.xxx L/h; range: 0.0...10 L/h
	(1st value = switching point / 2nd value = hysteresis), condition: 2nd value ≤ 1st value

C1.3 empty pipe detection

C1.3.1 empty pipe detect	Select: off / empty pipe (F); empty pipe (S); empty pipe (I)
	Flow indication "= 0" when "empty pipe"
C1.3.2 limit empty pipe	Only available if "empty pipe [..]" is activated in C1.3.1.
	Range: 0.0...9999 µS (set about 50% of the lowest occurring conductivity in operation.
	Conductivity below this value means a signal as "empty pipe".
C1.3.3 act. conductivity	Only available if "empty pipe [..]" is activated in C1.3.1.
	Actual conductivity is indicated. Activation takes place only after setting mode is exited!
C1.3.4 time constant	Only available if "empty pipe [..]" is activated in C1.3.1.
	Range: xxx.x s; 0.1...100 s
	A damping is set for empty pipe detection.

C1.4 information

C1.4.1 liner	Shows the material of the liner.
C1.4.2 electr. material	Shows the material of the electrodes.
C1.4.3 calibration date	Shows the date on which the flow tube was calibrated.
C1.4.4 serial no. sensor	Shows the serial number of the flow tube.
C1.4.5 V no. sensor	Shows the order number of the flow tube.
C1.4.6 sensor electr. info	Shows the serial number of the circuit board, the software version number and the calibration date of the circuit board.

C1.5 simulation

C1.5.2 volume flow C1.5.2 mass flow	For sequence refer to B1.1.
--	-----------------------------

Table 6-6: Menu C1

Function	Setting / Description
----------	-----------------------

C2 I/O (Inputs/Outputs)**C2.1 hardware**

C2.1.1 terminals A	Select: off (switched off) / current output
C2.1.2 terminals D	Select: off (switched off) / frequency output / pulse output / status output / limit switch

C2.2 current output A

C2.2.1 range 0%...100%	Current range for the selected "measurement", e.g. 4...20 mA, corresponds to 0...100%
	xx.x...xx.x mA; range: 0.00...20 mA Condition: 0 mA ≤ 1st value ≤ 2nd value ≤ 20 mA
C2.2.2 extended range	Min. and max. limits of current values. If the current range is exceeded, the current is set to these limits.
	xx.x ... xx.x mA; range: 03.5...21.5 mA Condition: 0 mA ≤ 1st value ≤ 2nd value ≤ 21.5 mA and out of current range
C2.2.3 error current	Specify error current.
	xx.x mA; range: 3...22 mA Condition: outside of extended range
C2.2.4 error condition	Set the error conditions.
	Select: error in device (error category [F]) / application error (error category [F]) / out of specification (error category [F] & [S])
C2.2.5 polarity	Set polarity; please note flow direction in C1.2.2!
	Select: both polarities (plus and minus values are displayed) / positive polarity (display for negative values = 0) / negative polarity (display for positive values = 0) / absolute value (always displays positive, with both negative and positive values)

Function	Setting / Description
C2.2.6 low flow cutoff	Sets the measurement to "0" for low values.
	x.xxx...x.xxx%; range: 0.0...20%
	{1st value = switching point / 2nd value = hysteresis}; condition: 2nd value ≤ 1st value
C2.2.7 time constant	Range: 000.1...100 s
C2.2.8 information	Serial number of the I/O board, software version number and production date of the circuit board.
C2.2.9 simulation	For sequence refer to "B1.2 current output A".
C2.2.10 4mA trimming	Trimming of the current at 4 mA.
	Reset to 4 mA restores the factory calibration.
	Used for HART® setting.
C2.2.11 20mA trimming	Trimming of the current at 20 mA.
	Reset to 20 mA restores the factory calibration.
	Used for HART® setting.

C2.3 frequency out X

C2.3.1 pulse shape	Specify the pulse shape.
	Select: symmetric (about 50% on and 50% off) / automatic (constant pulse with about 50% on and 50% off at 100% pulse rate) / fixed (fixed pulse rate; for setting refer to "C2.3.3 100% pulse rate")
C2.3.2 pulse width	Only available if set to "fixed" in C2.3.1.
	Range: 0.05...2000 ms
	Note: max. setting value T_p [ms] ≤ 500 / max. pulse rate [1/s], gives the pulse width = time where the output is activated
C2.3.3 100% pulse rate	Pulse rate for 100% of the measuring range.
	Range: 1...10000 Hz
	Limitation 100% pulse rate ≤ 100/s: $I_{max} \leq 100$ mA Limitation 100% pulse rate > 100/s: $I_{max} \leq 20$ mA
C2.3.4 polarity	Set polarity; please note flow direction in C1.2.2!
	Select: both polarities (plus and minus values are displayed) / positive polarity (display for negative values = 0) / negative polarity (display for positive values = 0) / absolute value (always displays positive, with both negative and positive values)
C2.3.5 low flow cutoff	Sets the measurement to "0" for low values.
	x.xxx ± x.xxx L/h; range: 0.0...20 L/h
	{1st value = switching point / 2nd value = hysteresis}, condition: 2nd value ≤ 1st value
C2.3.6 time constant	Range: 000.1...100 s
C2.3.7 invert signal	Select: off (activated output: switch closed) / on (activated output: switch open)
C2.3.8 information	Serial number of the I/O board, software version number and production date of the circuit board.
C2.3.9 simulation	For sequence refer to "B1.3 frequency out D".

C2.3 pulse output D

C2.3.1 pulse shape	Specify the pulse shape. Select: symmetric (about 50% on and 50% off) / automatic (constant pulse with about 50% on and 50% off at max. pulse rate) / fixed (fixed pulse rate, for setting refer to "C2.3.3 max. pulse rate")
C2.3.2 pulse width	Only available if set to "fixed" in C2.3.1. Range: 0.05...2000 ms Note: max. setting value T_p [ms] \leq 500 / max. pulse rate [1/s], gives the pulse width = time where the output is activated
C2.3.3 max. pulse rate	Setting the maximum pulse rate. Limit is 120% of this pulse rate.
C2.3.4 pulse value unit	Selection of the unit from a list, depending on the "measurement".
C2.3.5 value p. pulse	Set value for volume or mass per pulse. xxx.xxx, measured value
C2.3.6 polarity	Set polarity; please note flow direction in C1.2.2! Select: both polarities (plus and minus values are displayed) / positive polarity (display for negative values = 0) / negative polarity (display for positive values = 0) / absolute value (always displays positive, with both negative and positive values)
C2.3.7 invert signal	Select: off (activated output: switch closed) / on (activated output: switch open)
C2.3.8 information	Serial number of the I/O board, software version number and production date of the circuit board.
C2.3.9 simulation	For sequence refer to "B1.3 pulse output D".

C2.3 status output D

C2.3.1 mode	Measuring conditions of the output. Select: out of specification (output set, signals status of category "error in device" or "application error" or "out of specification" refer to <i>Status messages and diagnostic information</i> on page 69) / application error (output set, signals status of the category "error in device" or "application error" refer to <i>Status messages and diagnostic information</i> on page 69) / polarity flow (polarity of the current flow) / over range flow (over range of the flow) / counter 1 preset (activates counter 1 when preset value is reached) / counter 2 preset (activates counter 2 when preset value is reached) / output A (displays the polarity at output A) / off (switched off) / empty pipe (when pipe empty, output activated) / error in device (output set, signals status of the category "error in device" refer to <i>Status messages and diagnostic information</i> on page 69)
C2.3.2 invert signal	Select: off (activated output: switch closed) / on (activated output: switch open)
C2.3.3 information	Serial number of the I/O board, software version number and production date of the circuit board.
C2.3.4 simulation	For sequence refer to "B1.3 status output D".

C2.3 limit switch D

C2.3.1 threshold	Switching level, set threshold with hysteresis
C2.3.2 polarity	Set polarity; please note flow direction in C1.2.2! Select: both polarities (plus and minus values are displayed) / positive polarity (display for negative values = 0) / negative polarity (display for positive values = 0) / absolute value (always displays positive, with both negative and positive values)
C2.3.3 time constant	Range: 000.1...100 s
C2.3.4 invert signal	Select: off (activated output: switch closed) / on (activated output: switch open)
C2.3.5 information	Serial number of the I/O board, software version number and production date of the circuit board.
C2.3.6 simulation	For sequence refer to "B1.3 limit switch D".

Table 6-7: Menu C2

Function	Setting / Description
----------	-----------------------

C3 I/O counter

C3.1 counter 1	Set function of counter. _ stands for 1, 2 (= counter 1, 2)
C3.2 counter 2	
C3._1 funct. of counter	Select: sum counter (counts positive + negative values) / + counter (counts only the positive values) / - counter (counts only the negative values) / off (counter is switched off)
C3._2 preset value	If this value is reached, positive or negative, a signal is generated that can be used for a status output at which "preset counter X" has to be set. Preset value (max. 8 digits) x.xxxxx in selected unit; refer to C5.7.10 and C5.7.13
C3._3 reset counter	Query: reset counter? Select: no / yes (available if activated in C5.9.1)
C3._4 set counter	Set counter _ to the desired value. Select: break (exit function) / set value (opens the editor to make the entry) Query: set counter? Select: no (exit function without setting the value) / yes (sets the counter and exits the function)
C3._5 stop counter	Counter _ stops and holds the current value. Select: no (exits the function without stopping the counter) / yes (stop the counter and exits the function)
C3._5 start counter	Start counter _ after that counter is stopped. Select: no (exits the function without starting the counter) / yes (starts the counter and exits the function)
C3._7 information	Serial number of the I/O board, software version number and production date of the circuit board.

Table 6-8: Menu C3

Function	Setting / Description
C4 I/O HART	
The dynamic variables are fixed to the following values: PV: flow (volume flow or mass flow, depending on the selection of "measurement" in C1.1.4) SV: counter 1 TV: counter 2 4V: operating time	
C4.1 HART	HART [®] communication is activated or deactivated. Select: on (HART [®] is activated; default setting) / off (HART [®] is disabled)
C4.2 address	Setting the address for multi-drop operation. If "address 0" is selected, the current output is in normal operation. For all other addresses, the current at the output is set to the 0% value.
C4.3 message	Entry of individual text.
C4.4 description	Entry of individual text.
C4.5 HART units	Unit change of dynamic variables in the display. Select: break (return with ← key) / HART [®] display (copies the settings for the display units to the settings for the DVs) / load defaults (resets the DVs to the factory defaults)

Table 6-9: Menu C4

Function	Setting / Description
----------	-----------------------

C6 device**C6.1 device info**

C6.1.1 tag	Settable characters (max. 8 digits): A...Z; a...z; 0...9; / - , .
C6.1.2 C number	CG number, cannot be changed; describes the transmitter version.
C6.1.3 device serial no.	Serial number of the system; cannot be changed.
C6.1.4 electronic serial no.	Serial number of the electronic assembly; cannot be changed.
C6.1.5 SW.REV.MS	Serial number of the circuit board, version number of the main software, production date of the circuit board.
C6.1.6 Electronic Revision ER	Reference identification number, electronic revision and production date of the device; includes all hardware and software changes.

C6.2 display

C6.2.1 language	Language selection depends on the device version.
C6.2.2 contrast	Adjust display contrast for extreme temperatures. Setting: -9...0...+9 This change takes place immediately, not just when setting mode is exited!
C6.2.3 default display	Specification of the default display page that is returned to after a short delay period. Select: none (current page is always active) / 1. meas. page (shows this page) / 2. meas. page (shows this page) / status page (shows only status messages) / graphic page (trend of the 1st measurement)

Function	Setting / Description
C6.2.4 magnet keys	For activating or deactivating the magnet keys.
	Select: on (magnet keys are enabled) / off (magnet keys are disabled)
C6.2.5 status indication LED	This function is only available for device versions without display.
	Status display via a green or red LED (in case of device error, application error or out of specification).
SW.REV.UIS	Serial number of the circuit board, version number of user interface software, production date of the circuit board.

C6.3 1. meas. page

C6.3.1 format 1.line	Number of decimal places specified (depending on available space) for "1.line" of "1. meas. page".
----------------------	--

C6.4 2. meas. page

C6.4.1 format 1.line	Number of decimal places specified (depending on available space) for "1.line" of "2. meas. page".
C6.4.2 format 2.line	Number of decimal places specified (depending on available space) for "2.line" of "2. meas. page".
C6.4.3 format 3.line	Number of decimal places specified (depending on available space) for "3.line" of "2. meas. page".

C6.5 graphic page

C6.5.1 select range	Select: manual (set range in C6.5.2) / automatic (automatic depiction based on the measured values)
	Reset only after parameter change or after switching off and on.
C6.5.2 range	Set the scaling for the Y axis. Only available if "manual" is set in C6.5.1.
	±xxx...±xxx%; range: -100...+100%
	{1st value = lower limit / 2nd value = upper limit}, condition: 1st value ≤ 2nd value
C6.5.3 time scale	Set the time scaling for the X axis, trend curve
	xxx min; range: 0...100 min

C6.6 special function

C6.6.1 reset errors	Query: reset errors?
	Select: no / yes
C6.6.2 save settings	Save current settings.
	Select: break (exit function without saving) / backup 1 (saves the settings in the backup 1 storage place) / backup 2 (saves the settings in the backup 2 storage place)
	Query: go on with copy? (cannot be undone)
	Select: no (exit function without saving) / yes (copy current settings to storage backup 1 or backup 2)

Function	Setting / Description
C6.6.3 load settings	Load saved settings. Select: break (exit function without loading) / factory settings (reload factory settings) / backup 1 (loads the settings from the backup 1 storage place) / backup 2 (loads the settings from the backup 2 storage place) / load sensor data (restore factory setting of the values for the flow tube. Display and I/O settings are retained!)
	Query: go on with copy? (cannot be undone) Select: no (exit function without saving) / yes (load data from the selected storage place)
C6.6.4 password quick set	Password required to change data in the menu "quick setup".
	0000 (= to this menu without password)
	xxxx (password required); range 4 digits: 0001...9999
C6.6.5 password setup	Password required to change data in the menu "setup".
	0000 (= to this menu without password)
	xxxx (password required); range 4 digits: 0001...9999

C6.7 units

C6.7.1 volume flow	m ³ /h; m ³ /min; m ³ /s; L/h; L/min; L/s (L = litres); cf/h; cf/min; cf/s; gal/h; gal/min; gal/s; IG/h; IG/min; IG/s; free unit (set factor and text in the next two functions, sequence see below)
C6.7.2 Text free unit	For text to be specified refer to <i>Set free units</i> on page 67:
C6.7.3 [m ³ /s]*factor	Specification of the conversion factor, based on m ³ /s:
	xxx.xxx refer to <i>Set free units</i> on page 67
C6.7.4 mass flow	kg/s; kg/min; kg/h; t/min; t/h; g/s; g/min; g/h; lb/s; lb/min; lb/h; ST/min; ST/h (ST = Short Ton); LT/h (LT = Long Ton); free unit (set factor and text in the next two functions, sequence see below)
C6.7.5 Text free unit	For text to be specified refer to <i>Set free units</i> on page 67:
C6.7.6 [kg/s]*factor	Specification of the conversion factor, based on kg/s:
	xxx.xxx refer to <i>Set free units</i> on page 67
C6.7.7 volume	m ³ ; L; hL; mL; gal; IG; in ³ ; cf; yd ³ ; free unit (set factor and text in the next two functions, sequence see below)
C6.7.8 Text free unit	For text to be specified refer to <i>Set free units</i> on page 67:
C6.7.9 [m ³]*factor	Specification of the conversion factor, based on m ³ :
	xxx.xxx refer to <i>Set free units</i> on page 67
C6.7.10 mass	kg; t; mg; g; lb; ST; LT; oz; free unit (set factor and text in the next two functions, sequence see below)
C6.7.11 Text free unit	For text to be specified refer to <i>Set free units</i> on page 67:
C6.7.12 [kg]*factor	Specification of the conversion factor, based on kg:
	xxx.xxx refer to <i>Set free units</i> on page 67
C6.7.13 flow speed	m/s; ft/s
C6.7.14 density	kg/L; kg/m ³ ; lb/cf; lb/gal; free unit (set factor and text in the next two functions, sequence see below)
C6.7.15 Text free unit	For text to be specified refer to <i>Set free units</i> on page 67:

Function	Setting / Description
C6.7.16 [kg/m ³]*factor	Specification of the conversion factor, based on kg/m ³ : xxx.xxx refer to <i>Set free units</i> on page 67

C6.8 quick setup

Activate quick access in menu "quick setup"; default setting: "quick setup" is active (yes) Select: yes (activated) / no (not activated)	
C6.8.1 reset counter 1	Reset counter 1 in menu "quick setup". Select: yes (activated) / no (not activated)
C6.8.2 reset counter 2	Reset counter 2 in menu "quick setup". Select: yes (activated) / no (not activated)
C6.8.3 process input	Activate quick access to the important process input parameters. Select: yes (activated) / no (not activated)

Table 6-10: Menu C6

6.4.4 Set free units

Free units	Sequences to set texts and factors
Texts	
Volume flow, mass flow and density	3 digits before and after the slash xxx/xxx (max. 6 characters plus a "/")
Permissible characters	A...Z; a...z; 0...9; / - + , . *; @ \$ % ~ () [] _
Conversion factors	
Desired unit	= [unit see above] * conversion factor
Conversion factor	Max. 9 digits
Shift decimal point	↑ to the left and ↓ to the right

Table 6-11: Sequences to set texts and factors

6.5 Description of functions

6.5.1 Reset counter in the menu "quick setup"



NOTICE!

It may be necessary to activate resetting of the counter in the menu "quick setup".

Key	Function	Description
>	A quick setup	Press and hold for 2.5 s, then release the key.
>	A1 language	-
3 x ↓	A4 reset	-
>	A4.1 reset errors	-
↓	A4.2 counter 1	Select desired counter.
↓	A4.3 counter 2	
>	Query: reset counter? Select: no	-
↓ or ↑	Query: reset counter? Select: yes	-
↵	A4.2 counter 1 or A4.3 counter 2	Counter has been reset.
3 x ↵	Measuring mode	-

Table 6-12: Reset counter in the menu "quick setup"

6.5.2 Deleting error messages in the menu "quick setup"



NOTICE!

For the detailed list of the possible error messages refer to Status messages and diagnostic information on page 69.

Key	Function	Description
>	A quick setup	Press and hold for 2.5 s, then release the key.
>	A1 language	-
3 x ↓	A4 reset	-
>	A4.1 reset errors	-
>	Query: reset errors? Select: no	-
↓ or ↑	Query: reset errors? Select: yes	-
↵	A4.1 reset errors	Error has been reset.
3 x ↵	Measuring mode	-

Table 6-13: Deleting error messages in the menu "quick setup"

6.6 Status messages and diagnostic information

Messages on the display	Description	Actions
Status: F _ _ _ _ _	Operational fault in device, mA output \leq 3.6 mA or set fault current (depending on the seriousness of the fault), status output open, pulse / frequency output: no pulses	Repair necessary.
F error in device	Error or failure of device. Parameter or hardware error. No measurement possible.	Group message, when one of the following or some other severe error occurs.
F IO 1	Error, operational fault in IO 1. Parameter or hardware error. No measurement possible.	Load settings (C4.6.3) (backup 1, backup 2 or factory settings). If status message still does not disappear, replace electronic unit.
F parameter	Error, operational fault of data manager, electronic unit, parameter or hardware error. Parameters no longer usable.	
F configuration	Invalid configuration: display software, bus parameter or main software do not match existing configuration.	If device configuration unchanged: defective, replace electronic unit.
F display	Error, operational fault in display. Parameter or hardware error. No measurement possible.	Defective, replace electronic unit.
F sensor electronic	Error, operational fault in flow tube electronics. Parameter or hardware error. No measurement possible.	Defective, replace electronic unit.
F sensor global	Data error in the global data of the flow tube electronic equipment.	Load settings (C5.6.3) (backup 1, backup 2 or factory settings). If status message still does not disappear, replace electronic unit.
F sensor local	Data error in the local data of the flow tube electronic equipment.	Defective, replace electronic unit.
F field current local	Data error in the local data of the field current supply.	Defective, replace electronic unit.
F current output A	Error, operational fault in current output. Parameter or hardware error. No measurement possible.	Defective, replace electronic unit.
F current output C		
F software user interface	Fault revealed by CRC check of operation software.	Replace electronic unit.
F hardware settings	The set hardware parameters do not match the identified hardware. A dialogue appears in the display.	Answer queries in dialogue mode, follow directions. Defective, replace electronic unit.
F hardware detection	Existing hardware cannot be identified.	Defective, replace electronic unit.
F RAM/ROM error IO1	A RAM or ROM error is detected during the CRC check.	Defective, replace electronic unit.

Table 6-14: Operational faults in device

Messages on the display	Description	Actions
Status: F _ _ _ _ _	Application-dependent fault, device OK, but measured values affected.	Application test or operator action necessary.
F application error	Application-dependent fault, but device is OK.	Group message, when errors as described below or other application errors occur.
F empty pipe	1 or 2 measuring electrodes are not in contact with the medium; measured value is set to zero. No measurement possible.	Measuring pipe not filled; function dependent on C1.3.2. Check installation. Or electrodes completely insulated e.g. by oil film. Clean!
F flow exceeding limit	Measuring range exceeded, filter setting limits measured values. No message if empty pipe.	Limitation C1.2.1, increase values.
	If this limit occurs sporadically in processes with air pockets, solid contents or low conductivity, then either the limit has to be increased or a pulse filter used so as to quell the error messages and also reduce the measurement errors.	
F field frequency too high	Field frequency is not reaching steady state, a measured flow value is still being supplied but may have errors. Measured values are still supplied, but they are always too low. No message if coil broken or bridged.	If "C1.1.14 settling time" is set to "manual", increase value in C1.1.15. If "standard" is set, set the field frequency in C1.1.13 according to the transmitter nameplate.
F DC offset	ADC over-ranged by DC offsets. No measurement can be performed, the flow is set to zero. No message if empty pipe.	For remote transmitter, check the connection of the signal cable.
F open circuit A	Load on current output A too high, effective current too low.	Current not correct, mA output cable has open circuit or load too high. Check cable, reduce load (set < 750 Ω).
F open circuit C		
F over range A	The current or the corresponding measured value is limited by a filter setting.	Check with "C2.1 hardware" or the sticker in the terminal compartment, which output is connected to the terminal.
F over range C		
F over range D	The pulse rate or the corresponding measured value is limited by a filter setting. Or the demanded pulse rate is too high.	If current output: extend "C2.x.6 range" and "C2.x.8 limitation". If frequency output: extend values in "C2.x.5" and "C2.x.7".
F active settings	Error during the CRC check of the active settings.	Upload backup 1 or backup 2 settings, check and adjust if necessary.
F factory settings	Error during the CRC check of the factory settings.	-
F backup 1 settings	Error during the CRC check of the backup 1 or 2 settings.	Save active settings in backup 1 or 2.
F backup 2 settings		

Table 6-15: Application error

Messages on the display	Description	Actions
Status: S _ _ _ _ _	Out of specification, measurement continues, accuracy possibly less.	Maintenance required.
S uncertain measurement	Device maintenance necessary; measured values only conditionally usable.	Group message, when errors as described below or other influences occur.
S empty pipe	1 or 2 measuring electrodes are not in contact with the medium; measured value is set to zero. No measurement possible.	Measuring pipe not filled, function dependent on C1.3.2. Check installation. Or electrodes completely insulated e.g. by oil film. Clean!
S field coil broken	Field coil resistance too high.	Check field coil connections to the electronic module (for remote versions: field current cable) for open circuit / short circuit
S field coil bridged	Field coil resistance too low.	
S electronic temperature	Upper limit for the permissible electronic temperature has been exceeded.	Ambient temperature too high, direct solar radiation or, for C version, process temperature too high.
S overflow counter 1	This is counter 1. Counter has overrun and started again at zero.	-
S overflow counter 2	This is counter 2. Counter has overrun and started again at zero.	-
S backplane invalid	The data record on the backplane is invalid. The CRC check has revealed a fault.	No data can be loaded from the backplane when replacing electronics. Save the data to the backplane again (Service).
S field frequency too high	The field frequency is set so high that the field current cannot settle. The measured values displayed are too low.	Set field frequency lower; refer to C1.1.13.

Table 6-16: Measurements out of specification

Messages on the display	Description	Actions
Status: C _ _ _ _ _	Output values partially simulated or fixed	Maintenance required.
C checks in progress	Test mode of the device. Measured values are possibly simulated values or values with fixed settings.	Message depending on the situation via HART® or FDT.
C test sensor	Test function of the flow tube electronics is active.	-

Table 6-17: Simulation of the measured values

Messages on the display	Description	Actions
Status: I _ _ _ _ _	Information (current measurement OK)	
I counter 1 stopped	This is counter 1. The counter has stopped.	If counter to continue counting, activate "yes" in "C2.y.9 start counter".
I counter 2 stopped	This is counter 2. The counter has stopped.	
I power fail	The device was not in operation for an unknown period of time, because the power was switched off. This message is for information only.	Temporary power failure. Counters did not run during it.

Messages on the display	Description	Actions
Status: I _ _ _ _ _	Information (current measurement OK)	
I over range display 1	1st line on page 1 (2) of display limited by filter setting.	Menu display C4.3 and/or C4.4, select 1st or 2nd meas. page and increase values in "C4.z.3 range" and/or "C4.z.4 limitation".
I over range display 2		
I over range conductivity	The limits for the conductivity measurement have been exceeded ($>10000 \mu\text{S}/\text{cm}$) or are lower than permitted ($<0.1 \mu\text{S}/\text{cm}$).	If the flow tube has been properly connected and filled with medium, this does not affect the flow measurement. The conductivity measured values cannot be used.
I backplane sensor	The data on the backplane are not usable because they have been generated with an incompatible version.	-
I backplane settings	The global settings on the backplane are not usable because they have been generated with an incompatible version.	-
I backplane difference	The data on the backplane differ from the data in the display. If the data are usable, a dialogue is indicated in the display.	-
I conductivity off	Conductivity measurement switched off.	Changing of settings in C1.3.1.
I empty pipe	1 or 2 measuring electrodes are not in contact with the medium; measured value is set to zero. No measurement possible.	Measuring pipe not filled, function dependent on C1.3.2. Check installation. Or electrodes completely insulated e.g. by oil film. Clean!
I diagnosis channel off	Diagnosis value switched off.	Changing of settings in C1.3.17.

Table 6-18: Information

7.1 Spare parts availability

The manufacturer adheres to the basic principle that functionally adequate spare parts for each device or each important accessory part will be kept available for a period of 3 years after delivery of the last production run for the device.

This regulation only applies to spare parts which are subject to wear and tear under normal operating conditions.

7.2 Availability of services

The manufacturer offers a range of services to support the customer after expiration of the warranty. These include repair, maintenance, technical support and training.



NOTICE!

For more precise information, please contact your local sales office.

7.3 Returning the device to the manufacturer

7.3.1 General information

This device has been carefully manufactured and tested. If installed and operated in accordance with these operating instructions, it will rarely present any problems.



WARNING!

Should you nevertheless need to return a device for inspection or repair, please pay strict attention to the following points:

- *Due to statutory regulations on environmental protection and safeguarding the health and safety of the personnel, the manufacturer may only handle, test and repair returned devices that have been in contact with products without risk to personnel and environment.*
- *This means that the manufacturer can only service this device if it is accompanied by the following certificate (see next section) confirming that the device is safe to handle.*



WARNING!

If the device has been operated with toxic, caustic, radioactive, flammable or water-endangering products, you are kindly requested:

- *to check and ensure, if necessary by rinsing or neutralising, that all cavities are free from such dangerous substances,*
- *to enclose a certificate with the device confirming that it is safe to handle and stating the product used.*

7.3.2 Preapproval form - Customer returned process-wetted products

**LEGAL NOTICE!**

In compliance with U.S. Federal OSHA Standard 29CFR1910.1200 process information must be reviewed previous to receiving authorization to return material to Schneider Electric Systems USA, Inc.

NO PRODUCT EXPOSED TO HYDROFLUORIC ACID OR MERCURY WILL BE ACCEPTED!

Date: _____

Customer information

Customer's name:

Address:

Phone no:

Fax no.:

Contact's name:

Rep information

Rep's name:

Address:

Phone no:

Fax no.:

Contacts' name:

Product being returned:

Model No.:

Serial no.:

Under warranty?

YES

NO

Copies of MSDS sheets for all processes including cleaning solutions may be required.

Type of process (what chemicals/materials were processed through the unit):

Explain what steps were taken to decontaminate the unit: (was unit steam cleaned, rinsed out with water, chemically cleaned etc.)

Form completed by:

Print name

Signature

Date: _____

CLEANING STATEMENT

(Note: Your item will not be serviced unless the following cleaning statement has been signed):

I certify that the above referenced item has been properly purged and cleaned, complies with U.S. Department of Transportation shipping requirements and DOES NOT present a health and/or safety hazard (as defined by OSHA) to our Customer Repair personnel.

Print name: _____

Signature: _____

Print title: _____

Date: _____

Please fax the completed form to the Customer Satisfaction Center +1-508-549-4999

7.4 Disposal**LEGAL NOTICE!**

Disposal must be carried out in accordance with legislation applicable in your country.

Separate collection of WEEE (Waste Electrical and Electronic Equipment) in the European Union:

According to the directive 2012/19/EU, the monitoring and control instruments marked with the WEEE symbol and reaching their end-of-life **must not be disposed of with other waste**. The user must dispose of the WEEE to a designated collection point for the recycling of WEEE or send them back to our local organisation or authorised representative.

8.1 Measuring principle

An electrically conductive fluid flows inside an electrically insulated pipe through a magnetic field. This magnetic field is generated by a current, flowing through a pair of field coils.

Inside of the fluid, a voltage U is generated:

$$U = v * k * B * D$$

in which:

v = mean flow velocity

k = factor correcting for geometry

B = magnetic field strength

D = inner diameter of flowmeter

The signal voltage U is picked off by electrodes and is proportional to the mean flow velocity v and thus the flow rate Q . A signal transmitter is used to amplify the signal voltage, filter it and convert it into signals for totalizing, recording and output processing.

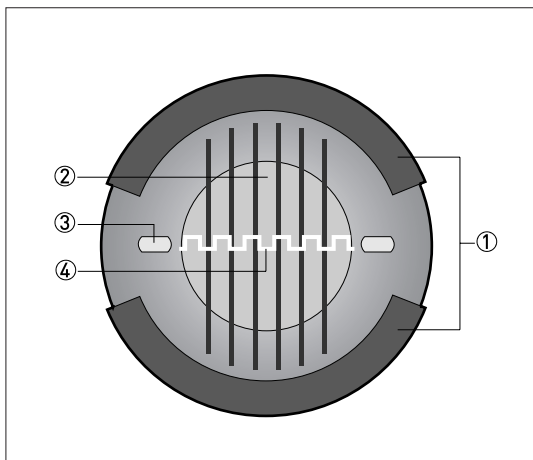

Figure 8-1: Measuring principle

- ① Field coils
- ② Magnetic field
- ③ Electrodes
- ④ Induced voltage (proportional to flow velocity)

8.2 Technical data



NOTICE!

- *The following data is provided for general applications. If you require data that is more relevant to your specific application, please contact us or your local sales office.*
- *Additional information (certificates, special tools, software,...) and complete product documentation can be downloaded free of charge from the website.*

Measuring system

Measuring principle	Faraday's law of induction
Application range	Continuous measurement of current volume flow, flow velocity, conductivity, mass flow (at constant density), coil temperature of the flow tube

Design

Modular construction	The measuring system consists of a flow tube and a transmitter.
Flow tube	
8400A	DN10...150 / 3/8...6"
8500A	DN2.5...100 / 1/10...4"
9500A	DN25...1200 / 1...48"
9600A	DN10...150 / 3/8...6"
9700A	DN10...1200 / 3/8...48"
Transmitter	
Compact (integral) version (C)	IMT30A 2 & IMT30A 4
Wall-mounted remote version (W)	IMT30A M & IMT30A N
Options	
Outputs	Current output (including HART®), pulse output, frequency output, status output and/or limit switch Note: It's not possible to use the pulse/frequency output with the status output at the same time!
Counter	2 internal counters with a max. of 10 counter places (e.g. for counting volume and/or mass units)
Verification	Integrated verification, diagnostic functions: measuring device, empty pipe detection, stabilisation
Communication interfaces	HART® Modbus

Display and user interface	
Graphic display	LC display, backlit white
	Size: 128 x 64 pixels, corresponds to 59 x 31 mm = 2.32" x 1.22"
	Ambient temperatures below -25°C / -13°F may affect the readability of the display.
Operating elements	4 push buttons for operating the transmitter when the housing is open.
	4 magnet keys for operating the transmitter when the housing is closed.
Remote control	Only generic and not device-specific DDs and DTMs available!
	PACTware™ (including Device Type Manager (DTM))
	HART® Communicator
	AMS®
	All DTMs and drivers are available free of charge from the manufacturer's website.
Display functions	
Operating menu	Setting the parameters using 2 measuring pages, 1 status page, 1 graphic page (measured values and graphics are freely adjustable)
Language display texts (as language package)	Standard: English, French, German, Dutch, Portuguese, Swedish, Spanish, Italian
	Eastern Europe: English, Slovenian, Czech, Hungarian
	Northern Europe: English, Danish, Polish, Finnish
	Southern Europe: English, Turkish
	China: English, German, Chinese (check www.BuyAutomation.com for availability)
Russia: English, German, Russian	
Units	Metric, British and US units selectable as required from lists for volume / mass flow and counting, flow velocity, electrical conductivity, temperature

Measuring accuracy

Max. measuring accuracy	Standard: ±0.5% of the measured value ± 1 mm/s
	Option (optimised accuracy with extended calibration): ±0.25% of the measured value ± 1.5 mm/s
	For detailed information and accuracy curves refer to <i>Measuring accuracy</i> on page 89.
	Special calibrations are available on request.
	Current output electronics: ±10 µA; ±100 ppm/°C (typically: ±30 ppm/°C)
Repeatability	±0.1%

Operating conditions

Temperature	
Process temperature	Refer to technical data for the flow tube.
Ambient temperature	Depending on the version and combination of outputs.
	It is a good idea to protect the transmitter from external heat sources such as direct sunlight as higher temperatures reduce the life cycle of all electronic components.
	Ambient temperatures below -25°C / -13°F may affect the readability of the display.
Storage temperature	-40...+70°C / -40...+158°F
Pressure	
Medium	Refer to technical data for the flow tube.
Ambient pressure	Atmosphere
Chemical properties	
Electrical conductivity	All media except for water: $\geq 5 \mu\text{S}/\text{cm}$ (also refer to the technical data for the flow tube)
	Water: $\geq 20 \mu\text{S}/\text{cm}$
State of aggregation	Conductive, liquid media
Solid content (volume)	$\leq 10\%$
Gas content (volume)	$\leq 3\%$
Flow rate	For detailed information, refer to chapter "Flow tables".
Other conditions	
Ingress protection according to IEC 60529	IP66/67 (according to NEMA 4/4X)

Installation conditions

Installation	For detailed information, refer to chapter "Installation".
Inlet / outlet sections	Refer to technical data for the flow tube.
Dimensions and weight	For detailed information refer to chapter "Dimensions and weight".

Materials

Transmitter housing	Aluminum with a polyester topcoat
Flow tube	For housing materials, process connections, liners, grounding electrodes and gaskets, refer to technical data for the flow tube.

Electrical connection

General	Electrical connection is carried out in conformity with the VDE 0100 directive "Regulations for electrical power installations with line voltages up to 1000 V" or equivalent national specifications.
Power supply	100...230 VAC (-15% / +10%), 50/60 Hz; 240 VAC + 5% is included in the tolerance range.
	24 VDC (-30% / +30%)
Power consumption	AC: 15 VA
	DC: 5.6 W
Signal cable	Only necessary for remote versions.
	DS 300 (type A) Max. length: 600 m / 1968 ft (depending on electrical conductivity and flow tube version)
Cable entries	Standard: M20 x 1.5 (8...12 mm)
	Option: 1/2 NPT, PF 1/2

Outputs

General	All outputs are electrically isolated from each other and from all other circuits.
	All operating data and output values can be adjusted.
Description of abbreviations	U_{ext} = external voltage; R_L = load + resistance; U_o = terminal voltage; I_{nom} = nominal current

Current output	
Output data	Flow
Settings	Without HART®
	Q = 0%: 0...20 mA; Q = 100%: 10...21.5 mA
	Error identification: 20...22 mA
	With HART®
	Q = 0%: 4...20 mA; Q = 100%: 10...21.5 mA
Error identification: 3...22 mA	
Operating data	Basic I/Os
Active	Observe connection polarity.
	$U_{\text{int, nom}} = 20 \text{ VDC}$
	$I \leq 22 \text{ mA}$
	$R_L \leq 750 \Omega$
	HART® at terminals A
Passive	Observe connection polarity.
	$U_{\text{ext}} \leq 32 \text{ VDC}$
	$I \leq 22 \text{ mA}$
	$U_0 \leq 2 \text{ V at } I = 22 \text{ mA}$
	$R_{L, \text{ max}} = (U_{\text{ext}} - U_0) / I_{\text{max}}$
	HART® at terminals A
HART®	
Description	HART® protocol via active and passive current output
	HART® version: V5
	Universal Common Practice HART® parameter: completely supported
Load	$\geq 230 \Omega$ at HART® test point; Note maximum load for current output!
Multi-drop mode	Yes, current output = 4 mA
	Multi-drop address adjustable in operation menu 1...15

Pulse or frequency output	
Output data	Flow
Function	Can be set as a pulse output or frequency output
Pulse rate/frequency	0.01...10000 pulses/s or Hz
Settings	Pulses per volume or mass unit or max. frequency for 100% flow
	Pulse width: adjustable as automatic, symmetric or fixed (0.05...2000 ms)
Operating data	Basic I/Os + Modbus
Active	This output is intended to drive mechanical or electronic counters directly.
	$U_{int, nom} \leq 20 \text{ V}$ $R_V = 1 \text{ k}\Omega$ $C = 1000 \mu\text{F}$
	High current mechanical counter $f_{max} \leq 1 \text{ Hz}$
	Low current mechanical counter $I \leq 20 \text{ mA}$ $R_L \leq 10 \text{ k}\Omega$ for $f \leq 1 \text{ kHz}$ $R_L \leq 1 \text{ k}\Omega$ for $f \leq 10 \text{ kHz}$ closed: $U_0 \geq 12.5 \text{ V}$ at $I = 10 \text{ mA}$ open: $I \leq 0.05 \text{ mA}$ at $U_{nom} = 20 \text{ V}$
Passive	Independent of connection polarity.
	$U_{ext} \leq 32 \text{ VDC}$
	f_{max} in operating menu set to $f_{max} \leq 100 \text{ Hz}$: $I \leq 100 \text{ mA}$ open: $I \leq 0.05 \text{ mA}$ at $U_{ext} = 32 \text{ VDC}$ closed: $U_{0, max} = 0.2 \text{ V}$ at $I \leq 10 \text{ mA}$ $U_{0, max} = 2 \text{ V}$ at $I \leq 100 \text{ mA}$
	f_{max} in operating menu set to $100 \text{ Hz} < f_{max} \leq 10 \text{ kHz}$: $I \leq 20 \text{ mA}$ open: $I \leq 0.05 \text{ mA}$ at $U_{ext} = 32 \text{ VDC}$ closed: $U_{0, max} = 1.5 \text{ V}$ at $I \leq 1 \text{ mA}$ $U_{0, max} = 2.5 \text{ V}$ at $I \leq 10 \text{ mA}$ $U_{0, max} = 5.0 \text{ V}$ at $I \leq 20 \text{ mA}$

Low flow cut off	
Function	Switching point and hysteresis separately adjustable for each output, counter and the display
Switching point	Set in increments of 0.1%.
	0...20% (current output, frequency output) or 0...±9.999 m/s (pulse output)
Hysteresis	Set in increments of 0.1%.
	0...5% (current output, frequency output) or 0...5 m/s (pulse output)
Time constant	
Function	The time constant corresponds to the elapsed time until 67% of the end value has been reached according to a step function.
Settings	Set in increments of 0.1 seconds.
	0...100 seconds
Status output / limit switch	
Function and settings	Adjustable as automatic measuring range conversion, display of flow direction, counter overflow, error, switching point or empty pipe detection
	Valve control with activated dosing function
	Status and/or control: ON or OFF
Operating data	
Passive	Basic I/Os + Modbus
	Independent of connection polarity. $U_{ext} \leq 32 \text{ VDC}$ $I \leq 100 \text{ mA}$ open: $I \leq 0.05 \text{ mA}$ at $U_{ext} = 32 \text{ VDC}$ closed: $U_0 = 0.2 \text{ V}$ at $I \leq 10 \text{ mA}$ $U_0 = 2 \text{ V}$ at $I \leq 100 \text{ mA}$
Modbus	
Description	Modbus RTU, Master / Slave, RS485
Address range	1...247
Broadcast	Supported with function code 16
Supported Baud rate	1200, 2400, 3600, 4800, 9600, 19200, 38400, 57600, 115200 Baud

Approvals and certificates

CE	This device fulfils the statutory requirements of the relevant EU directives. The manufacturer certifies successful testing of the product by applying the CE mark.
	For full information of the EU directives & standards and the approved certifications, please refer to the EU declaration or the manufacturer website.
Other standards and approvals	
Vibration resistance	Tested according to IEC 60068-2-64
NAMUR	NE 21, NE 43, NE 53

8.3 Dimensions and weight

8.3.1 Housing

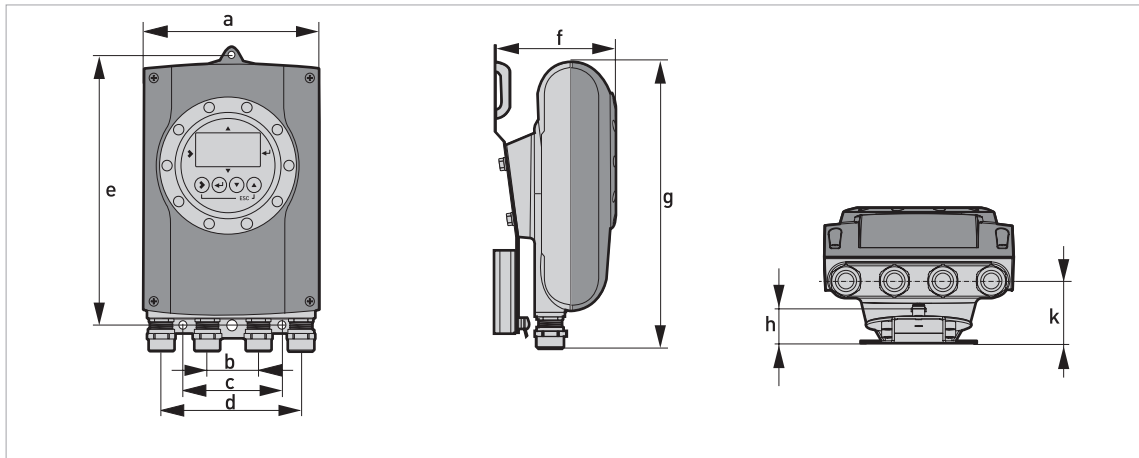

Figure 8-2: Dimensions of wall version

	Dimensions [mm]									Weight [kg]
	a	b	c	d	e	f	g	h	k	
Version with & without display	157	40	80	120	248	111.7	260	28.4	51.3	1.9

Table 8-1: Dimensions and weight in mm and kg

	Dimensions [inch]									Weight [lb]
	a	b	c	d	e	f	g	h	k	
Version with & without display	6.18	1.57	3.15	4.72	9.76	4.39	10.24	1.12	2.02	4.2

Table 8-2: Dimensions and weight in inch and lb

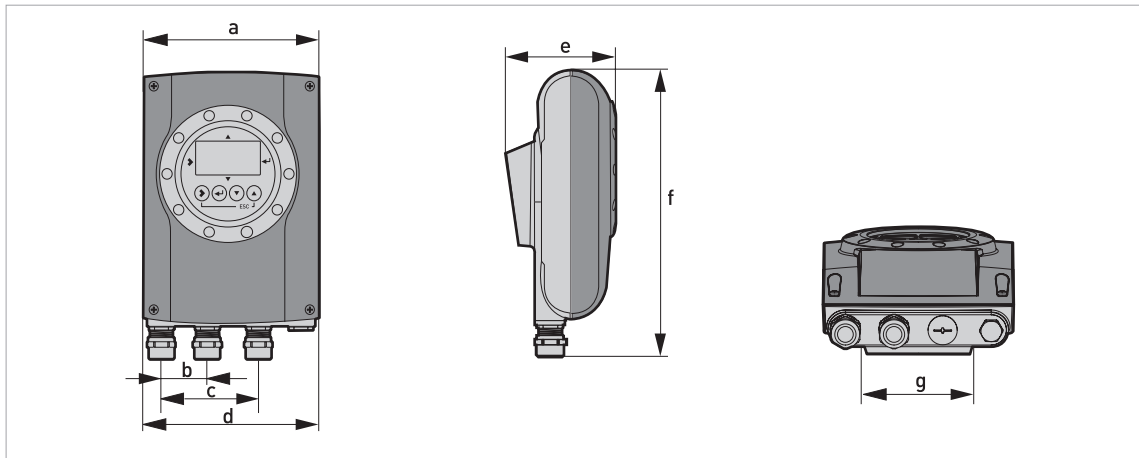

Figure 8-3: Dimensions of compact version

	Dimensions [mm]							Weight [kg]
	a	b	c	d	e	f	g	
Version with & without display	157	40	80	148.2	101	260	95.5	1.8

Table 8-3: Dimensions and weight in mm and kg

	Dimensions [inch]							Weight [lb]
	a	b	c	d	e	f	g	
Version with & without display	6.18	1.57	3.15	5.83	3.98	10.24	3.76	4.0

Table 8-4: Dimensions and weight in inch and lb

8.3.2 Mounting plate, wall version

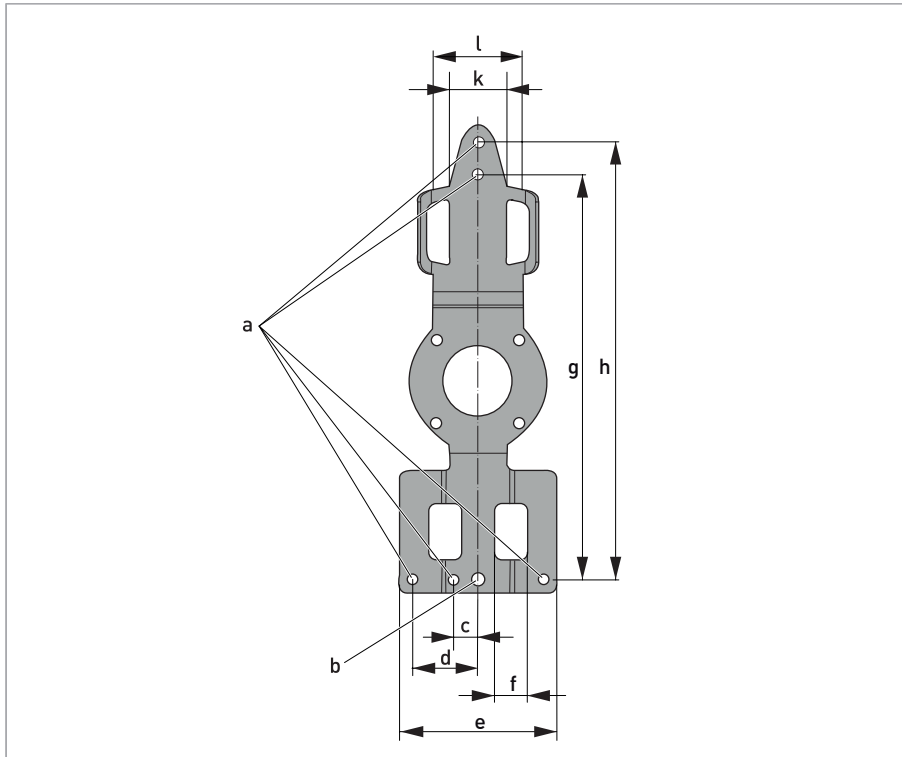

Figure 8-4: Dimensions of mounting plate, wall version

	[mm]	[inch]
a	Ø6.5	Ø0.26
b	Ø8.1	Ø0.3
c	15	0.6
d	40	1.6
e	96	3.8
f	20	0.8
g	248	9.8
h	268	10.5
k	35	1.4
l	55	2.2

Table 8-5: Dimensions in mm and inch

8.4 Flow tables

	Q _{100 %} in m ³ /h			
v [m/s]	0.3	1	3	12
DN [mm]	Minimum flow	Nominal flow		Maximum flow
2.5	0.005	0.02	0.05	0.21
4	0.01	0.05	0.14	0.54
6	0.03	0.10	0.31	1.22
10	0.08	0.28	0.85	3.39
15	0.19	0.64	1.91	7.63
20	0.34	1.13	3.39	13.57
25	0.53	1.77	5.30	21.21
32	0.87	2.90	8.69	34.74
40	1.36	4.52	13.57	54.29
50	2.12	7.07	21.21	84.82
65	3.58	11.95	35.84	143.35
80	5.43	18.10	54.29	217.15
100	8.48	28.27	84.82	339.29
125	13.25	44.18	132.54	530.15
150	19.09	63.62	190.85	763.40
200	33.93	113.10	339.30	1357.20
250	53.01	176.71	530.13	2120.52
300	76.34	254.47	763.41	3053.64
350	103.91	346.36	1039.08	4156.32
400	135.72	452.39	1357.17	5428.68
450	171.77	572.51	1717.65	6870.60
500	212.06	706.86	2120.58	8482.32
600	305.37	1017.90	3053.70	12214.80
700	415.62	1385.40	4156.20	16624.80
800	542.88	1809.60	5428.80	21715.20
900	687.06	2290.20	6870.60	27482.40
1000	848.22	2827.40	8482.20	33928.80
1200	1221.45	3421.20	12214.50	48858.00

Table 8-6: Flow rate in m/s and m³/h

	Q ₁₀₀ % in US gallons/min			
v [ft/s]	1	3.3	10	40
DN [inch]	Minimum flow	Nominal flow		Maximum flow
1/10	0.02	0.09	0.23	0.93
1/6	0.06	0.22	0.60	2.39
1/4	0.13	0.44	1.34	5.38
3/8	0.37	1.23	3.73	14.94
1/2	0.84	2.82	8.40	33.61
3/4	1.49	4.98	14.94	59.76
1	2.33	7.79	23.34	93.36
1.25	3.82	12.77	38.24	152.97
1.5	5.98	19.90	59.75	239.02
2	9.34	31.13	93.37	373.47
2.5	15.78	52.61	159.79	631.16
3	23.90	79.69	239.02	956.09
4	37.35	124.47	373.46	1493.84
5	58.35	194.48	583.24	2334.17
6	84.03	279.97	840.29	3361.17
8	149.39	497.92	1493.29	5975.57
10	233.41	777.96	2334.09	9336.37
12	336.12	1120.29	3361.19	13444.77
14	457.59	1525.15	4574.93	18299.73
16	597.54	1991.60	5975.44	23901.76
18	756.26	2520.61	7562.58	30250.34
20	933.86	3112.56	9336.63	37346.53
24	1344.50	4481.22	13445.04	53780.15
28	1829.92	6099.12	18299.20	73196.79
32	2390.23	7966.64	23902.29	95609.15
36	3025.03	10082.42	30250.34	121001.37
40	3734.50	12447.09	37346.00	149384.01
48	5377.88	17924.47	53778.83	215115.30

Table 8-7: Flow rate in ft/s and US gallons/min

8.5 Measuring accuracy

Every electromagnetic flowmeter is calibrated by direct volume comparison. The wet calibration validates the performance of the flowmeter under reference conditions against accuracy limits.

The accuracy limits of electromagnetic flowmeters are typically the result of the combined effect of linearity, zero point stability and calibration uncertainty.

Reference conditions

- Medium: water
- Temperature: +5...+35°C / +41...+95°F
- Operating pressure: 0.1...5 barg / 1.5...72.5 psig
- Inlet section: ≥ 5 DN; outlet section: ≥ 2 DN

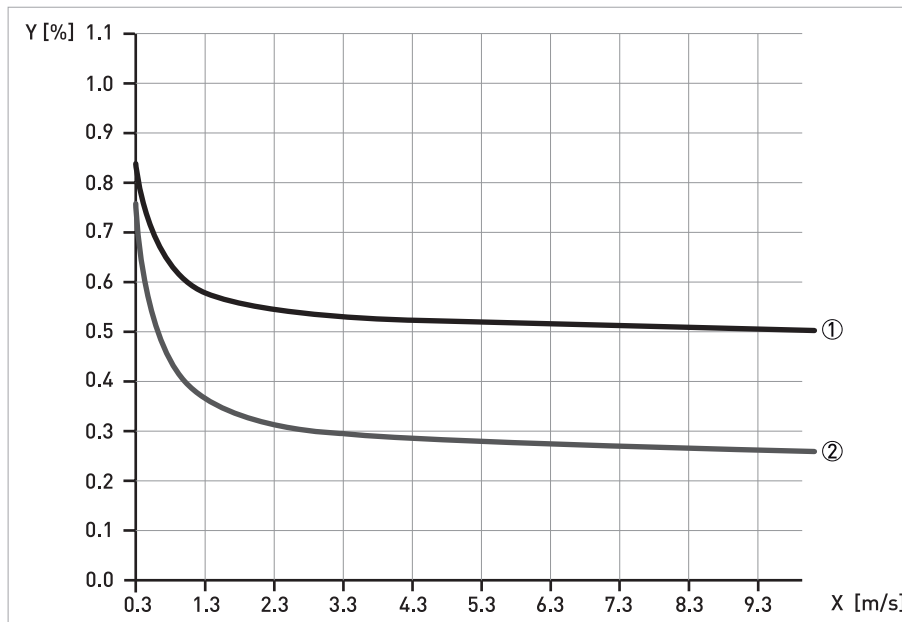

Figure 8-5: Measuring accuracy

X [m/s]: flow velocity

Y [%]: accuracy of measured value (mv)

	DN [mm]	DN [inch]	Standard accuracy ①	Optimised accuracy ②
8400A	10...150	3/8...6	±0.5% of mv ± 1 mm/s	only 9500A / 9700A: ±0.25% of mv ± 1.5 mm/s Extended calibration at 2 points
8500A	2.5...100	1/10...4		
9500A	25...1200	1...48		
9600A	10...150	3/8...6		
9700A	10...1200	3/8...48		

Table 8-8: Measuring accuracy





Schneider Electric Systems USA, Inc. Global Customer Support
38 Neponset Avenue Inside U.S.: 1-866-746-6477
Foxboro, MA 02035 Outside U.S.: 1-508-549-2424
United States of America <https://pasupport.schneider-electric.com>
<http://www.se.com>

Copyright 2020 Schneider Electric Systems USA, Inc.
All rights reserved.

The Schneider Electric brand and any trademarks of
Schneider Electric SE or its subsidiaries are the property
of Schneider Electric SE or its subsidiaries.
All other trademarks are the property of their respective
owners.

