

Instruction

MI 021-515 en

APR 2020

Model IMT31A Magnetic Flow Transmitter

Master Instruction

All rights reserved. It is prohibited to reproduce this documentation, or any part thereof, without the prior written authorisation of Schneider Electric Systems USA, Inc.

Copyright 2019-2020 Schneider Electric Systems USA, Inc.

1	Safety instructions	6
1.1	Software history	6
1.2	Intended use	7
1.3	Certifications	7
1.4	Safety instructions from the manufacturer	8
1.4.1	Copyright and data protection	8
1.4.2	Disclaimer	8
1.4.3	Product liability and warranty	9
1.4.4	Information concerning the documentation	9
1.4.5	Warnings and symbols used	10
1.5	Safety instructions for the operator	11
2	Device description	12
2.1	Scope of delivery	12
2.2	Device description	13
2.3	Nameplates	14
2.3.1	Nameplate (example)	14
3	Installation	15
3.1	General notes on installation	15
3.2	Storage	15
3.3	Transport	15
3.4	Installation specifications	15
3.5	Mounting of the compact version	16
3.6	Mounting the wall-mounted housing, remote version	16
3.6.1	Wall mounting	16
4	Electrical connections	19
4.1	Safety instructions	19
4.2	Important notes on electrical connection	19
4.3	Electrical cables for remote device versions, notes	20
4.3.1	Notes on signal cable A	20
4.3.2	Notes on field current cable C	20
4.3.3	Requirements for signal cables provided by the customer	21
4.4	Preparing the signal and field current cables	22
4.4.1	Signal cable A (type DS 300), construction	22
4.4.2	Preparing signal cable A, connection to transmitter	23
4.4.3	Length of signal cable A	24
4.4.4	Preparing field current cable C, connection to transmitter	25
4.4.5	Preparing signal cable A, connection to flow tube	27
4.4.6	Preparing field current cable C, connection to flow tube	28
4.5	Connecting the signal and field current cables	29

4.5.1	Connecting the signal and field current cables to the transmitter, remote version.....	30
4.5.2	Connection diagram for signal and field current cable	33
4.6	Grounding the flow tube	34
4.6.1	Classical method.....	34
4.7	Connecting the power supply.....	35
4.8	Inputs and outputs, overview	37
4.8.1	Description of the CG number	37
4.8.2	Fixed, non-alterable input/output versions.....	37
4.9	Description of the inputs and outputs.....	38
4.9.1	Current output	38
4.9.2	Pulse output and frequency output	39
4.9.3	Status output and limit switch	40
4.9.4	Control input	41
4.10	Electrical connection of the outputs	42
4.10.1	Electrical connection of the outputs.....	42
4.10.2	Laying electrical cables correctly.....	43
4.11	Connection diagrams of outputs	43
4.11.1	Important notes.....	43
4.11.2	Description of the electrical symbols	44
4.11.3	Basic inputs/outputs	45
4.11.4	HART connection.....	50
5	Start-up	52
<hr/>		
5.1	Switching on the power	52
5.2	Starting the transmitter	52
6	Operation	53
<hr/>		
6.1	Display and operating elements	53
6.1.1	Display in measuring mode with 2 or 3 measured values	54
6.1.2	Display for selection of submenu and functions, 3 lines	54
6.1.3	Display when setting parameters, 4 lines	55
6.1.4	Display when previewing parameters, 4 lines.....	55
6.2	Menu structure	56
6.3	Function tables	58
6.3.1	Menu "A quick setup"	58
6.3.2	Menu "B test"	60
6.3.3	Menu "C setup"	61
6.3.4	Set free units.....	76
6.4	Description of functions	77
6.4.1	Reset counter in the menu "quick setup"	77
6.4.2	Deleting error messages in the menu "quick setup"	77
6.5	Status messages and diagnostic information.....	78
7	Service	83
<hr/>		

7.1 Spare parts availability.....	83
7.2 Availability of services	83
7.3 Returning the device to the manufacturer.....	83
7.3.1 General information.....	83
7.3.2 Preapproval form - Customer returned process-wetted products.....	84
7.4 Disposal	85
8 Technical data	86
<hr/>	
8.1 Measuring principle.....	86
8.2 Technical data.....	87
8.3 Dimensions and weight	95
8.3.1 Housing	95
8.3.2 Mounting plate of wall-mounted version, aluminium housing.....	99
8.3.3 Mounting plate of wall-mounted version, stainless steel housing.....	100
8.4 Flow tables	101
8.5 Measuring accuracy	103
9 Description of HART interface	104
<hr/>	
9.1 General description	104
9.2 Software history	104
9.3 Connection variants.....	105
9.3.1 Point-to-Point connection - analogue / digital mode.....	106
9.3.2 Multi-drop connection (2-wire connection).....	107
9.3.3 Multi-drop connection (3-wire connection).....	108
9.4 Inputs/outputs and HART dynamic variables and device variables	109
9.5 Parameter for the basic configuration.....	110
9.6 HART Communicator.....	111
9.6.1 Installation	111
9.6.2 Operation.....	111
9.6.3 Parameter for the basic configuration	111
9.7 Asset Management Solutions (AMS).....	112
9.7.1 Installation	112
9.7.2 Operation.....	112
9.7.3 Parameter for the basic configuration	112
9.8 Field Device Tool / Device Type Manager (FDT / DTM).....	113
9.8.1 Installation	113
9.8.2 Operation.....	113
9.9 Appendix A: HART menu tree for Basic-DD.....	113
9.9.1 Overview Basic-DD menu tree (positions in menu tree).....	114
9.9.2 Basic-DD menu tree (details for settings).....	115
9.10 Appendix B: HART menu tree for AMS.....	118
9.10.1 Overview AMS menu tree (positions in menu tree).....	118
9.10.2 AMS menu tree (details for settings).....	119
10 Notes	123
<hr/>	

1.1 Software history

The "Electronic Revision" (ER) is consulted to document the revision status of electronic equipment according to NE 53 for all devices. It is easy to see from the ER whether troubleshooting or larger changes in the electronic equipment have taken place and how that has affected the compatibility.

1	Downwards compatible changes and fault repair with no effect on operation (e.g. spelling mistakes on display)	
2- <u> </u>	Downwards compatible hardware and/or software change of interfaces:	
	H	HART®
	F	Foundation Fieldbus
	M	Modbus
	P	Profibus
X	all interfaces	
3- <u> </u>	Downwards compatible hardware and/or software change of inputs and outputs:	
	I	Current output
	F, P	Frequency / pulse output
	S	Status output
	C	Control input
	CI	Current input
X	all inputs and outputs	
4	Downwards compatible changes with new functions	
5	Incompatible changes, i.e. electronic equipment must be changed.	

Table 1-1: Description of changes



NOTICE!

In the table below, " " is a placeholder for possible multi-digit alphanumeric combinations, depending on the available version.

Release date	Electronic revision	Changes and compatibility	Issue date of documentation
2016	ER 3.1.2_ <u> </u>	Initial version	FEB 2016
2017	ER 3.1.2_ <u> </u>	1; 2-P	MAY 2017
	ER 3.1.3_ <u> </u>	1; 2-F; 3-F; 3-P	APR 2020
	ER 3.1.4_ <u> </u> ER 3.1.5_ <u> </u>		

Table 1-2: Changes and effect on compatibility

1.2 Intended use

The electromagnetic flowmeters are designed exclusively to measure the flow and conductivity of electrically conductive, liquid media.

**DANGER!**

For devices used in hazardous areas, additional safety notes apply; please refer to the Ex documentation.

**WARNING!**

If the device is not used according to the operating conditions, the intended protection could be affected.

**NOTICE!**

This device is a Group 1, Class A device as specified within CISPR11:2009. It is intended for use in industrial environment. There may be potential difficulties in ensuring electromagnetic compatibility in other environments, due to conducted as well as radiated disturbances.

1.3 Certifications

CE marking



The manufacturer certifies successful testing of the product by applying the CE mark.

This device fulfils the statutory requirements of the relevant EU directives.

For full information of the EU directives and standards and the approved certifications, please refer to the EU Declaration of Conformity or the website of the manufacturer.

Other approvals and standards

- NAMUR recommendations NE 21 and NE 43

**DANGER!**

For devices used in hazardous areas, additional safety notes apply; please refer to the Ex documentation.

1.4 Safety instructions from the manufacturer

1.4.1 Copyright and data protection

The contents of this document have been created with great care. Nevertheless, we provide no guarantee that the contents are correct, complete or up-to-date.

The contents and works in this document are subject to copyright. Contributions from third parties are identified as such. Reproduction, processing, dissemination and any type of use beyond what is permitted under copyright requires written authorisation from the respective author and/or the manufacturer.

The manufacturer tries always to observe the copyrights of others, and to draw on works created in-house or works in the public domain.

The collection of personal data (such as names, street addresses or e-mail addresses) in the manufacturer's documents is always on a voluntary basis whenever possible. Whenever feasible, it is always possible to make use of the offerings and services without providing any personal data.

We draw your attention to the fact that data transmission over the Internet (e.g. when communicating by e-mail) may involve gaps in security. It is not possible to protect such data completely against access by third parties.

We hereby expressly prohibit the use of the contact data published as part of our duty to publish an imprint for the purpose of sending us any advertising or informational materials that we have not expressly requested.

1.4.2 Disclaimer

The manufacturer will not be liable for any damage of any kind by using its product, including, but not limited to direct, indirect or incidental and consequential damages.

This disclaimer does not apply in case the manufacturer has acted on purpose or with gross negligence. In the event any applicable law does not allow such limitations on implied warranties or the exclusion of limitation of certain damages, you may, if such law applies to you, not be subject to some or all of the above disclaimer, exclusions or limitations.

Any product purchased from the manufacturer is warranted in accordance with the relevant product documentation and our Terms and Conditions of Sale.

The manufacturer reserves the right to alter the content of its documents, including this disclaimer in any way, at any time, for any reason, without prior notification, and will not be liable in any way for possible consequences of such changes.

1.4.3 Product liability and warranty

The operator shall bear responsibility for the suitability of the device for the specific purpose. The manufacturer accepts no liability for the consequences of misuse by the operator. Improper installation or operation of the devices (systems) will cause the warranty to be void. The respective "Standard Terms and Conditions" which form the basis for the sales contract shall also apply.

1.4.4 Information concerning the documentation

To prevent any injury to the user or damage to the device it is essential that you read the information in this document and observe applicable national standards, safety requirements and accident prevention regulations.

If this document is not in your native language and if you have any problems understanding the text, we advise you to contact your local office for assistance. The manufacturer can not accept responsibility for any damage or injury caused by misunderstanding of the information in this document.

This document is provided to help you establish operating conditions, which will permit safe and efficient use of this device. Special considerations and precautions are also described in the document, which appear in the form of icons as shown below.

1.4.5 Warnings and symbols used

Safety warnings are indicated by the following symbols.

**DANGER!**

This warning refers to the immediate danger when working with electricity.

**DANGER!**

This warning refers to the immediate danger of burns caused by heat or hot surfaces.

**DANGER!**

This warning refers to the immediate danger when using this device in a hazardous atmosphere.

**DANGER!**

These warnings must be observed without fail. Even partial disregard of this warning can lead to serious health problems and even death.

**WARNING!**

Disregarding this safety warning, even if only in part, poses the risk of serious health problems. There is also the risk of damaging the device or parts of the operator's plant.

**CAUTION!**

Disregarding these instructions can result in damage to the device or to parts of the operator's plant.

**NOTICE!**

These instructions contain important information for the handling of the device.

**LEGAL NOTICE!**

This note contains information on statutory directives and standards.

• **HANDLING**

This symbol designates all instructions for actions to be carried out by the operator in the specified sequence.

➔ **RESULT**

This symbol refers to all important consequences of the previous actions.

1.5 Safety instructions for the operator

**WARNING!**

In general, devices from the manufacturer may only be installed, commissioned, operated and maintained by properly trained and authorized personnel.

This document is provided to help you establish operating conditions, which will permit safe and efficient use of this device.

2.1 Scope of delivery

**NOTICE!**

Inspect the packaging carefully for damages or signs of rough handling. Report damage to the carrier and to the local office of the manufacturer.

**NOTICE!**

Do a check of the packing list to make sure that you have all the elements given in the order.

**NOTICE!**

Look at the device nameplate to ensure that the device is delivered according to your order. Check for the correct supply voltage printed on the nameplate.

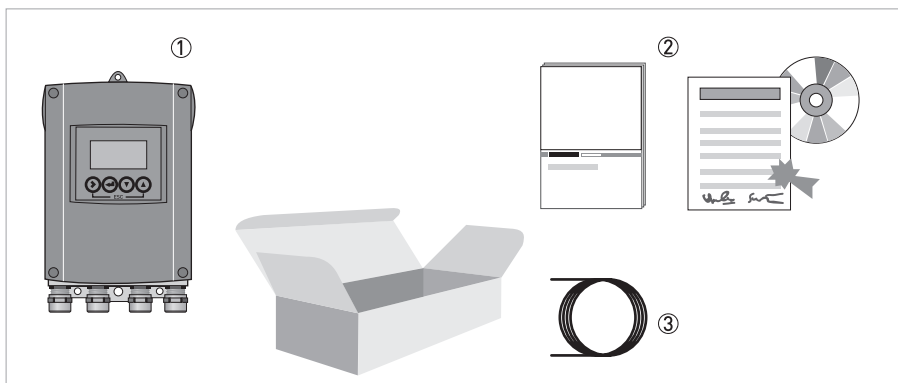

Figure 2-1: Scope of delivery

- ① Device in the version as ordered
- ② Documentation (calibration report, DVD with product documentation for flow tube and transmitter)
- ③ Signal cable (only for remote version)

2.2 Device description

Electromagnetic flowmeters are designed exclusively to measure the flow and conductivity of electrically conductive, liquid media.

Your measuring device is supplied ready for operation. The factory settings for the operating data have been made in accordance with your order specifications.

The following versions are available:

- Compact version (the transmitter is mounted directly on the flow tube)
- Remote version (electrical connection to the flow tube via field current and signal cable)

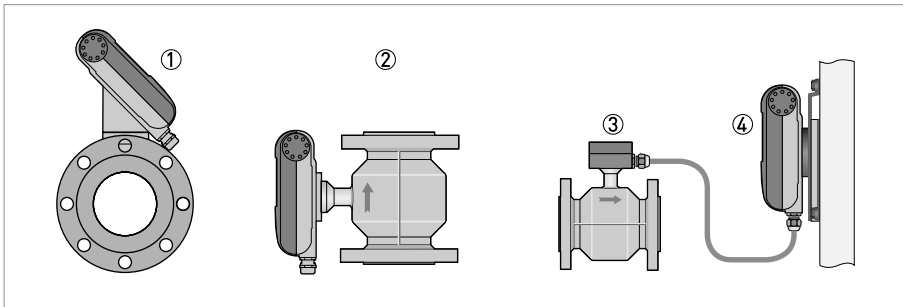

Figure 2-2: Device versions

- ① Compact version as 45° version
- ② Compact version as 0° version
- ③ Flow tube with connection box
- ④ Wall version

2.3 Nameplates



NOTICE!

Look at the device nameplate to ensure that the device is delivered according to your order. Check for the correct supply voltage printed on the nameplate.

2.3.1 Nameplate (example)

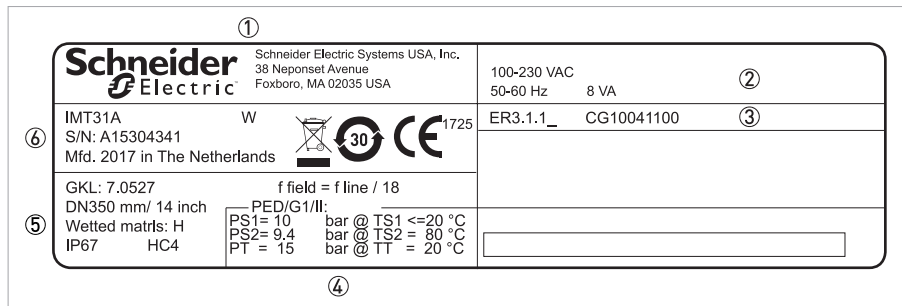

Figure 2-3: Example of a nameplate

- ① Manufacturer address
- ② Data for power supply
- ③ Software revision number (Electronic Revision)
- ④ Approvals-related data (e.g. temperature thresholds and pressure thresholds)
- ⑤ GKL values (flow tube constants), size (mm/inch), field frequency, ingress protection and materials of wetted parts
- ⑥ Product designation, serial number, manufacturing date and country, disposal and China RoHs marking

3.1 General notes on installation

**NOTICE!**

Inspect the packaging carefully for damages or signs of rough handling. Report damage to the carrier and to the local office of the manufacturer.

**NOTICE!**

Do a check of the packing list to make sure that you have all the elements given in the order.

**NOTICE!**

Look at the device nameplate to ensure that the device is delivered according to your order. Check for the correct supply voltage printed on the nameplate.

3.2 Storage

- Store the device in a dry, dust-free location.
- Avoid continuous direct sunlight.
- Store the device in its original packing.
- Storage temperature: -40...+70°C / -40...+158°F

3.3 Transport

Transmitter

- No special requirements.

Compact version

- Do not lift the device by the transmitter housing.
- Do not use lifting chains.
- To transport flange devices, use lifting straps. Wrap these around both process connections.

3.4 Installation specifications

**NOTICE!**

The following precautions must be taken to ensure reliable installation.

- *Make sure that there is adequate space to the sides.*
- *The device must not be heated by radiated heat (e.g. exposure to the sun) to an electronics housing surface temperature above the maximum permissible ambient temperature. If it is necessary to prevent damage from heat sources, a heat protection (e.g. sun shade) has to be installed.*
- *Transmitters installed in control cabinets require adequate cooling, e.g. by fan or heat exchanger.*
- *Do not expose the transmitter to intense vibrations. The measuring devices are tested for a vibration level as described in the chapter "Technical data".*

3.5 Mounting of the compact version



CAUTION!

Turning the housing of the compact version is not permitted.



NOTICE!

The transmitter is mounted directly on the flow tube. For installation of the flowmeter, please observe the instructions in the supplied product documentation for the flow tube.

3.6 Mounting the wall-mounted housing, remote version



NOTICE!

Assembly materials and tools are not part of the delivery. Use the assembly materials and tools in compliance with the applicable occupational health and safety directives.

3.6.1 Wall mounting

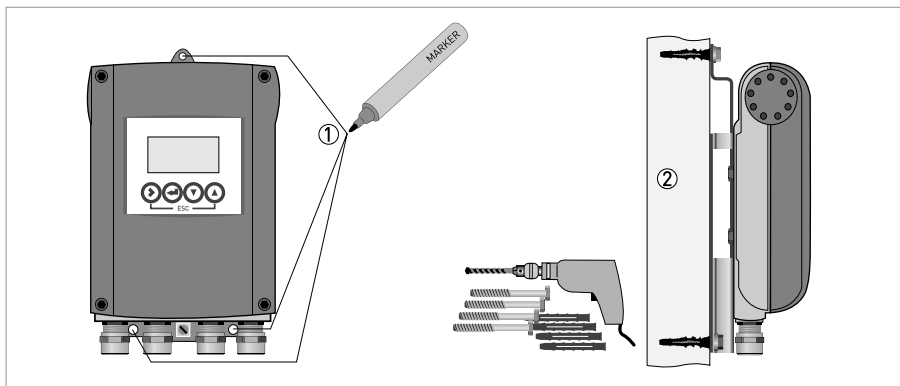

Figure 3-1: Mounting the wall-mounted housing



- ① Prepare the holes with the aid of the mounting plate. For further information refer to *Mounting plate of wall-mounted version, aluminium housing* on page 99.
- ② Fasten the device securely to the wall with the mounting plate.

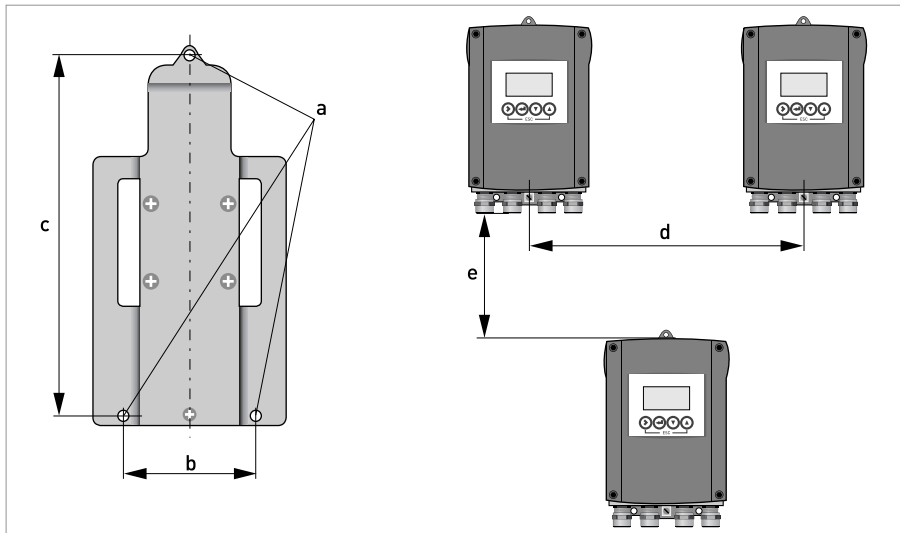

Figure 3-2: Wall mounting of multiple devices (aluminium housing)

	[mm]	[inch]
a	Ø6.5	Ø0.26
b	87.2	3.4
c	241	9.5
d	310	12.2
e	257	10.1

Table 3-1: Dimensions in mm and inch

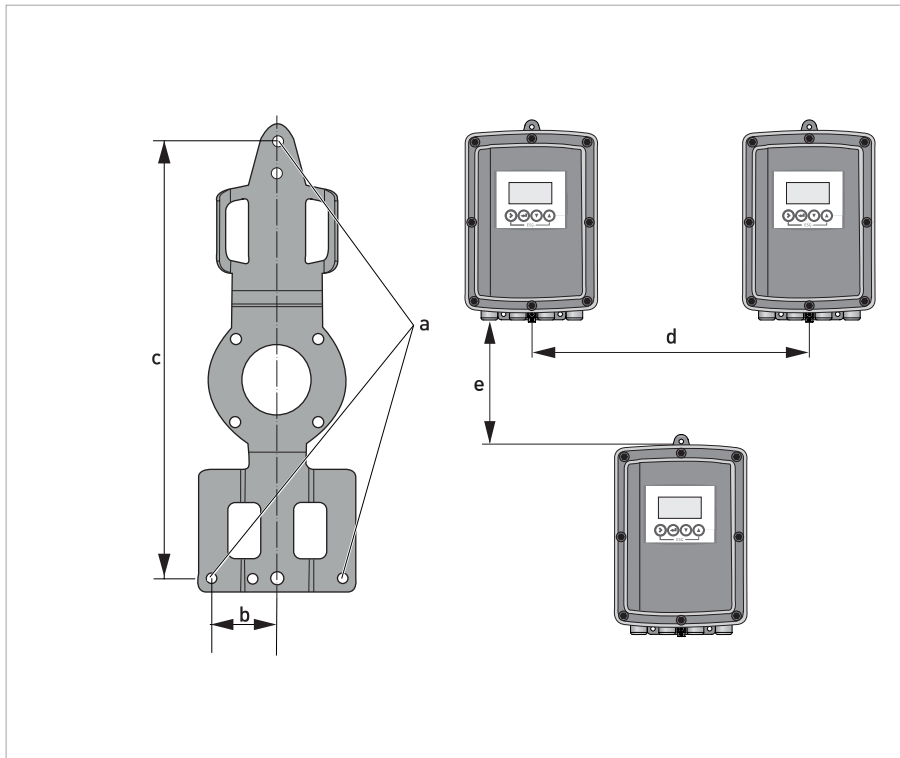

Figure 3-3: Wall mounting of multiple devices (stainless steel housing)

	[mm]	[inch]
a	Ø6.5	Ø0.26
b	268	10.5
c	40	1.6
d	336	13.2
e	257	10.1

Table 3-2: Dimensions in mm and inch

4.1 Safety instructions



DANGER!

All work on the electrical connections may only be carried out with the power disconnected. Take note of the voltage data on the nameplate!



DANGER!

Observe the national regulations for electrical installations!



DANGER!

For devices used in hazardous areas, additional safety notes apply; please refer to the Ex documentation.



WARNING!

Observe without fail the local occupational health and safety regulations. Any work done on the electrical components of the measuring device may only be carried out by properly trained specialists.



NOTICE!

Look at the device nameplate to ensure that the device is delivered according to your order. Check for the correct supply voltage printed on the nameplate.

4.2 Important notes on electrical connection



DANGER!

Electrical connection is carried out in conformity with the VDE 0100 directive "Regulations for electrical power installations with line voltages up to 1000 V" or equivalent national regulations.



DANGER!

The device must be grounded in accordance with regulations in order to protect personnel against electric shocks.



CAUTION!

- *Use suitable cable entries for the various electrical cables.*
- *The flow tube and transmitter have been configured together at the factory. For this reason, please connect the devices in pairs.*
- *If delivered separately or when installing devices that were not configured together, set the transmitter to the DN size and GK/GKL of the flow tube, refer to Function tables on page 58.*

4.3 Electrical cables for remote device versions, notes

4.3.1 Notes on signal cable A

**NOTICE!**

Signal cable A (type DS 300) with double shield ensures proper transmission of measured values.

Observe the following notes:

- Lay the signal cable with fastening elements.
- It is permissible to lay the signal cable in water or in the ground.
- The insulating material is flame-retardant.
- The signal cable does not contain any halogens and is unplasticized, and remains flexible at low temperatures.
- The connection of the inner shield (10) is carried out via the stranded drain wire (1).
- The connection of the outer shield (60) is carried out via the stranded drain wire (6).

4.3.2 Notes on field current cable C

**DANGER!**

*A shielded 2-wire copper cable is used for the field current cable. The shielding **MUST** be connected in the housing of the flow tube and transmitter.*

**NOTICE!**

The field current cable is not part of the scope of delivery.

4.3.3 Requirements for signal cables provided by the customer

**NOTICE!**

If the signal cable was not ordered, it is to be provided by the customer. The following requirements regarding the electrical values of the signal cable must be observed:

Electrical safety

- According to low voltage directive or equivalent national regulations.

Capacitance of the insulated conductors

- Insulated conductor / insulated conductor < 50 pF/m
- Insulated conductor / shield < 150 pF/m

Insulation resistance

- $R_{iso} > 100 \text{ G}\Omega \times \text{km}$
- $U_{max} < 24 \text{ V}$
- $I_{max} < 100 \text{ mA}$

Test voltages

- Insulated conductor / inner shield 500 V
- Insulated conductor / insulated conductor 1000 V
- Insulated conductor / outer shield 1000 V

Twisting of the insulated conductors

- At least 10 twists per meter, important for screening magnetic fields.

4.4 Preparing the signal and field current cables



NOTICE!

Assembly materials and tools are not part of the delivery. Use the assembly materials and tools in compliance with the applicable occupational health and safety directives.

4.4.1 Signal cable A (type DS 300), construction

- Signal cable A is a double-shielded cable for signal transmission between the flow tube and transmitter.
- Bending radius: $\geq 50 \text{ mm} / 2''$

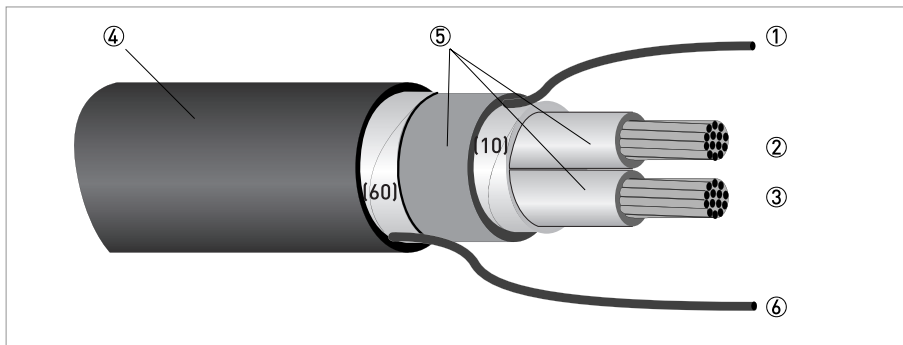

Figure 4-1: Construction of signal cable A

- ① Stranded drain wire (1) for the inner shield (10), $1.0 \text{ mm}^2 \text{ Cu}$ / AWG 17 (not insulated, bare)
- ② Insulated wire (2), $0.5 \text{ mm}^2 \text{ Cu}$ / AWG 20
- ③ Insulated wire (3), $0.5 \text{ mm}^2 \text{ Cu}$ / AWG 20
- ④ Outer sheath
- ⑤ Insulation layers
- ⑥ Stranded drain wire (6) for the outer shield (60)

4.4.2 Preparing signal cable A, connection to transmitter



NOTICE!

Assembly materials and tools are not part of the delivery. Use the assembly materials and tools in compliance with the applicable occupational health and safety directives.

- Connection of the two shields in the transmitter is carried out via the stranded drain wires.
- Bending radius: $\geq 50 \text{ mm} / 2''$

Required materials

- PVC insulating tube, $\varnothing 2.5 \text{ mm} / 0.1''$
- Heat-shrinkable tubing
- 2 wire end ferrules to DIN 46228: E 1.5-8 for the stranded drain wires (1, 6)
- 2 wire end ferrules to DIN 46228: E 0.5-8 for the insulated conductors (2, 3)

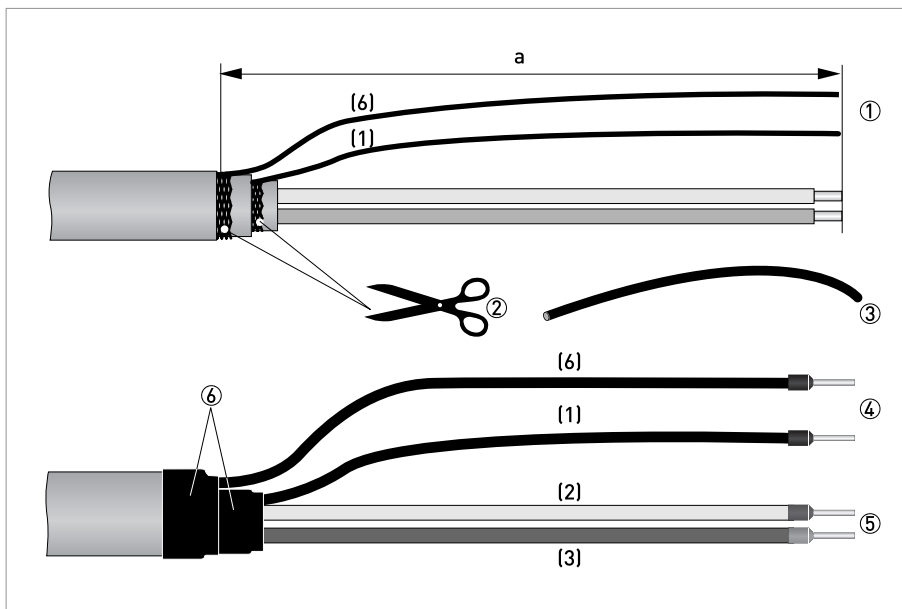

Figure 4-2: Preparation of signal cable A

$a = 80 \text{ mm} / 3.15''$



- ① Strip the conductor to dimension a .
- ② Cut off the inner shield (10) and the outer shield (60). Make sure not to damage the stranded drain wires (1, 6).
- ③ Slide the insulating tubes over the stranded drain wires (1, 6).
- ④ Crimp the wire end ferrules onto the stranded drain wire.
- ⑤ Crimp the wire end ferrules onto the conductors (2, 3).
- ⑥ Pull the heat-shrinkable tubing over the prepared signal cable.

4.4.3 Length of signal cable A



NOTICE!

For temperatures of the medium above 150° C / 300° F, a special signal cable and a ZD intermediate socket are necessary. These are available including the changed electrical connection diagrams.

Flow tube	Nominal diameter		Min. electrical conductivity [µS/cm]	Curve for signal cable A
	DN [mm]	[inch]		
8400A	10...150	3/8...6	5	A1
8500A	2.5...100	1/10...4	5	A1
	150...250	6...10	5	A2
9500A	25...150	1...6	20	A1
	200...1200	8...48	20	A2
9600A	2.5...150	1/10...6	5	A1
9700A	2.5...150	1/10...6	5	A1
	200...1200	8...48	5	A2

Table 4-1: Length of signal cable A

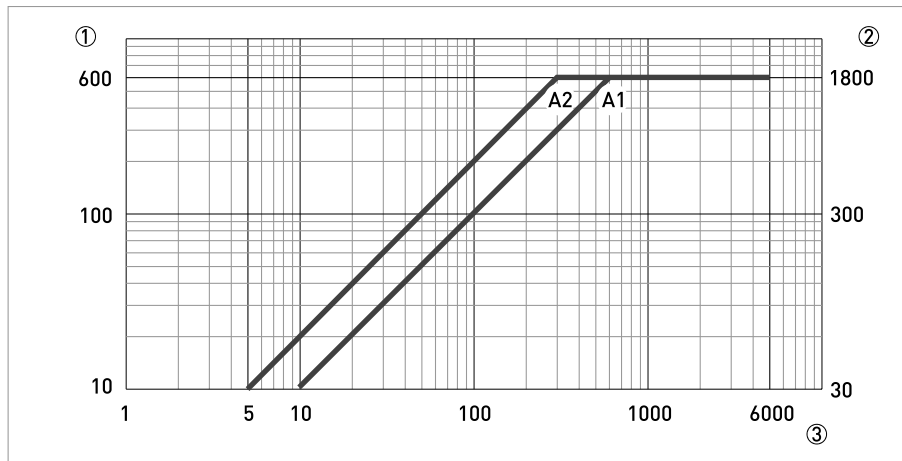

Figure 4-3: Maximum length of signal cable A

- ① Maximum length of signal cable A between the flow tube and transmitter [m]
- ② Maximum length of signal cable A between the flow tube and transmitter [ft]
- ③ Electrical conductivity of the medium being measured [µS/cm]

4.4.4 Preparing field current cable C, connection to transmitter



DANGER!

A shielded 2-wire copper cable is used as the field current cable. The shielding **MUST** be connected in the housing of the flow tube and transmitter.



NOTICE!

Assembly materials and tools are not part of the delivery. Use the assembly materials and tools in compliance with the applicable occupational health and safety directives.

- Field current cable C is not part of the scope of delivery.
- Bending radius: ≥ 50 mm / 2"

Required materials:

- Shielded, at least 2-wire copper cable with suitable heat-shrinkable tubing
- Insulating tube, size according to the cable being used
- Wire end ferrules to DIN 46228: size according to the cable being used

Length		Cross-section A_F (Cu)	
[m]	[ft]	[mm ²]	[AWG]
0...150	0...492	2 x 0.75 Cu ①	2 x 18
150...300	492...984	2 x 1.5 Cu ①	2 x 14
300...600	984...1968	2 x 2.5 Cu ①	2 x 12

Table 4-2: Length and cross-section of field current cable C

① Cu = copper cross-section

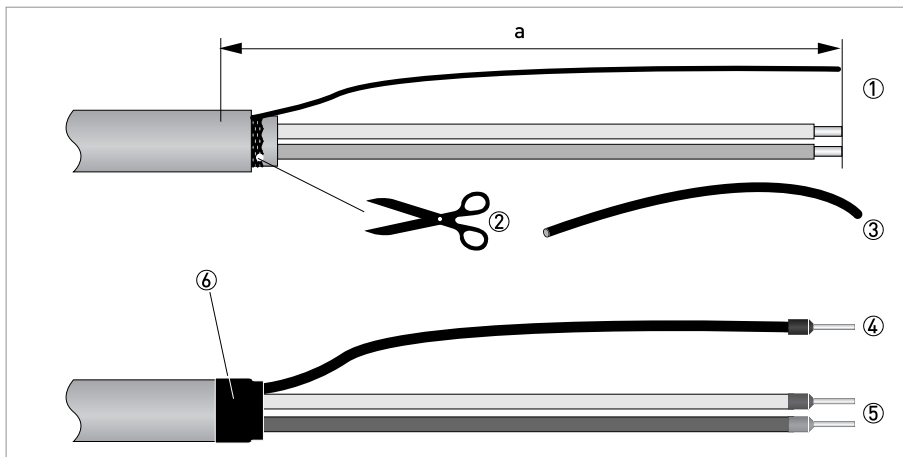

Figure 4-4: Field current cable C, preparation for the transmitter

$a = 80 \text{ mm} / 3.15''$



- ① Strip the conductor to dimension a.
- ② If a stranded drain wire is present, remove the shield that is present. Make sure not to damage the stranded drain wire.
- ③ Slide an insulating tube over the stranded drain wire.
- ④ Crimp a wire end ferrule onto the stranded drain wire.
- ⑤ Crimp the wire end ferrules on the conductors.
- ⑥ Pull a shrinkable tube over the prepared cable.

4.4.5 Preparing signal cable A, connection to flow tube



NOTICE!

Assembly materials and tools are not part of the delivery. Use the assembly materials and tools in compliance with the applicable occupational health and safety directives.

- The outer shield (60) is connected in the terminal compartment of the flow tube directly via the shield and a clip.
- Bending radius: $\geq 50 \text{ mm} / 2''$

Required materials

- PVC insulating tube, $\varnothing 2.0 \dots 2.5 \text{ mm} / 0.08 \dots 0.1''$
- Heat-shrinkable tubing
- Wire end ferrule to DIN 46228: E 1.5-8 for the stranded drain wire (1)
- 2 wire end ferrules to DIN 46228: E 0.5-8 for the insulated conductors (2, 3)

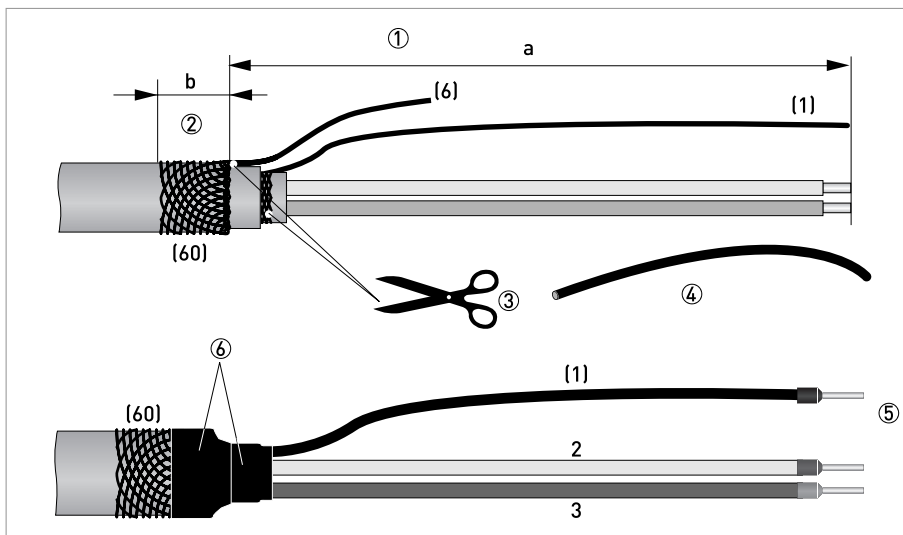

Figure 4-5: Preparing signal cable A, connection to flow tube

a = 50 mm / 2"

b = 10 mm / 0.4"



- ① Strip the conductor to dimension a.
- ② Trim the outer shield (60) to dimension b and pull it over the outer sheath.
- ③ Remove the stranded drain wire (6) of the outer shield and the inner shield. Make sure not to damage the stranded drain wire (1) of the inner shield.
- ④ Slide an insulating tube over the stranded drain wire (1).
- ⑤ Crimp the wire end ferrules onto conductors 2 and 3 and the stranded drain wire (1).
- ⑥ Pull the heat-shrinkable tubing over the prepared signal cable.

4.4.6 Preparing field current cable C, connection to flow tube

**NOTICE!**

Assembly materials and tools are not part of the delivery. Use the assembly materials and tools in compliance with the applicable occupational health and safety directives.

- The field current cable is not part of the scope of delivery.
- The shield is connected in the terminal compartment of the flow tube directly via the shield and a clip.
- Bending radius: $\geq 50 \text{ mm} / 2''$

Required materials

- Shielded 2-wire insulated copper cable
- Insulating tube, size according to the cable being used
- Heat-shrinkable tubing
- Wire end ferrules to DIN 46228: size according to the cable being used

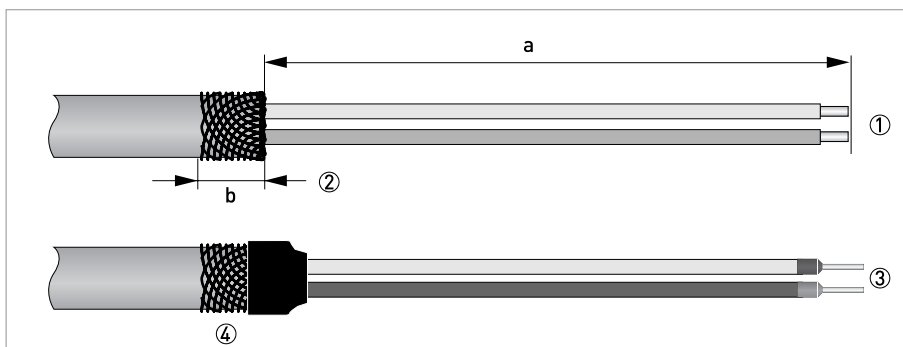

Figure 4-6: Preparation of field current cable C

$a = 50 \text{ mm} / 2''$

$b = 10 \text{ mm} / 0.4''$



- ① Strip the conductor to dimension a.
- ② Trim the outer shield to dimension b and pull it over the outer sheath.
- ③ Crimp wire end ferrules onto both conductors.
- ④ Pull a shrinkable tube over the prepared cable.

4.5 Connecting the signal and field current cables

**DANGER!**

Cables may only be connected when the power is switched off.

**DANGER!**

The device must be grounded in accordance with regulations in order to protect personnel against electric shocks.

**DANGER!**

For devices used in hazardous areas, additional safety notes apply; please refer to the Ex documentation.

**WARNING!**

*Observe without fail the local occupational health and safety regulations.
Any work done on the electrical components of the measuring device may only be carried out by properly trained specialists.*

4.5.1 Connecting the signal and field current cables to the transmitter, remote version

**NOTICE!**

The compact version is supplied preassembled from the factory.

Opening and closing the aluminium housing

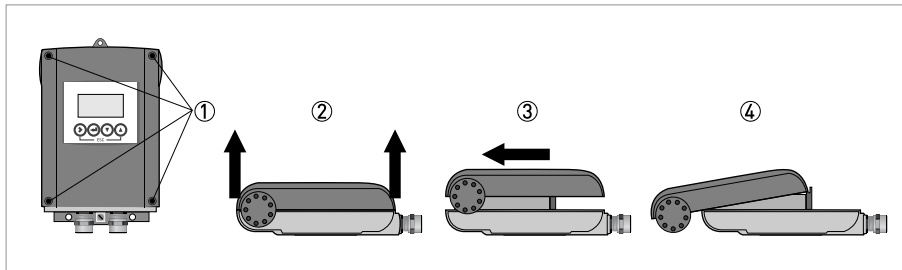

Figure 4-7: Opening and closing the aluminium housing



- ① Loosen the 4 screws with a suitable tool.
 - ② Lift the housing at the top and bottom at the same time.
 - ③ Slide the housing cover upward.
 - ④ The housing cover is guided and held by the inside hinge.
- ➡ There is now access to the terminal compartment for connection.

After completion of work, close the transmitter housing.

Opening and closing the stainless steel housing

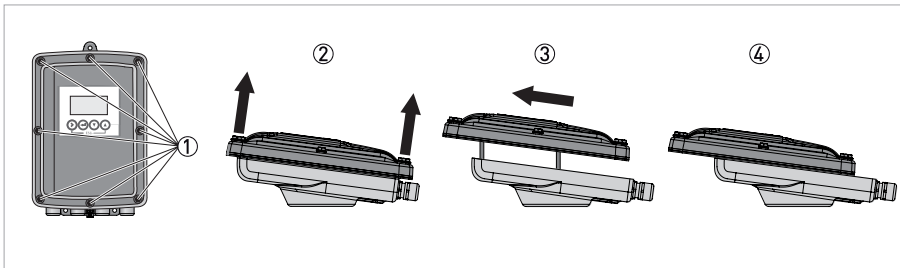

Figure 4-8: Opening and closing the stainless steel housing



- ① Loosen the 8 hexagon screws with a 10 mm spanner socket.
- ② Lift the housing at the top and bottom at the same time.
- ③ Slide the housing cover backward.
- ④ The housing cover is guided and held by the inside hinge.
- ➡ There is now access to the terminal compartment for connection.

After completion of work, close the transmitter housing. To achieve a proper sealing of the device tighten the screws in the following order with a torque of 5 Nm.

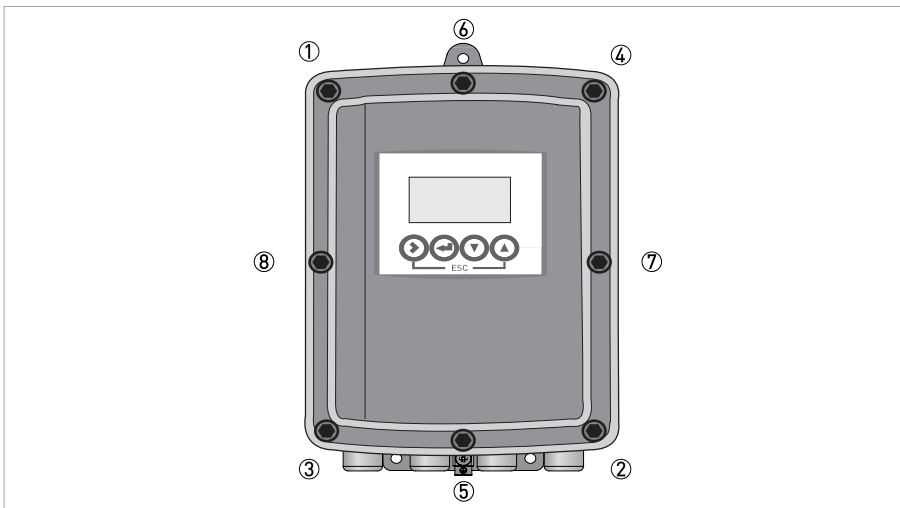

Figure 4-9: Tighten the screws

Connecting the signal and field current cables

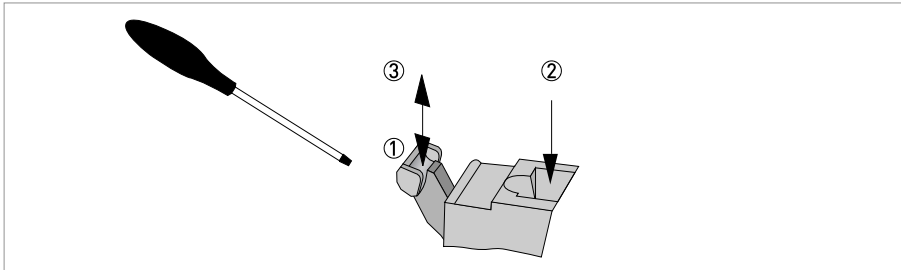

Figure 4-10: Function of the electrical connection terminal



Connect the electrical conductors as follows:

- ① Push the lever downwards with a screwdriver in good condition (blade: 3.5 mm wide and 0.5 mm thick).
- ② Insert the electrical conductor into the plug.
- ③ The conductor will be clamped as soon as the lever is released.

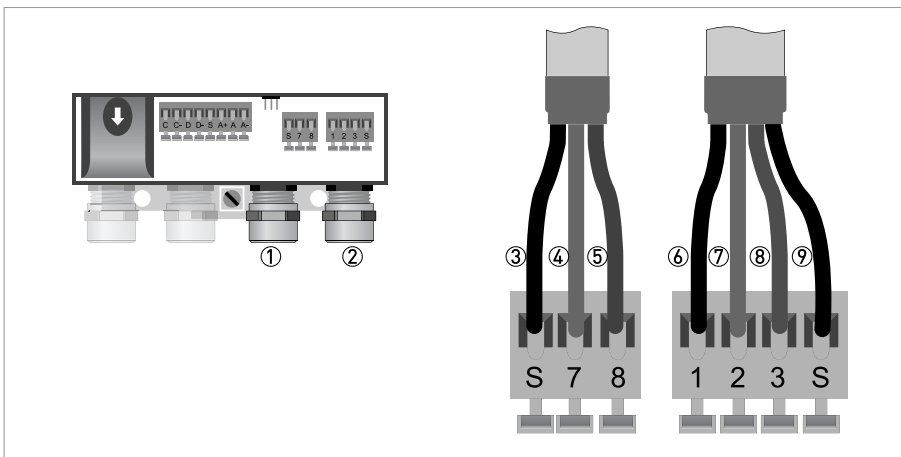

Figure 4-11: Connecting the signal and field current cables

- ① Cable entry for field current cable
- ② Cable entry for signal cable
- ③ Connecting the field current cable shield
- ④ Electrical conductor (7)
- ⑤ Electrical conductor (8)
- ⑥ Stranded drain wire (1) of the inner shield (10) of the signal cable
- ⑦ Electrical conductor (2)
- ⑧ Electrical conductor (3)
- ⑨ Stranded drain wire (S) of the outer shield (60)

4.5.2 Connection diagram for signal and field current cable



DANGER!

The device must be grounded in accordance with regulations in order to protect personnel against electric shocks.

- A shielded 2-wire copper cable is used as the field current cable. The shielding **MUST** be connected in the housing of the flow tube and transmitter.
- The outer shield (60) is connected in the terminal compartment of the flow tube directly via the shield and a clip.
- Bending radius of signal and field current cable: $\geq 50 \text{ mm} / 2''$
- The following illustration is schematic. The positions of the electrical connection terminals may vary depending on the housing version.

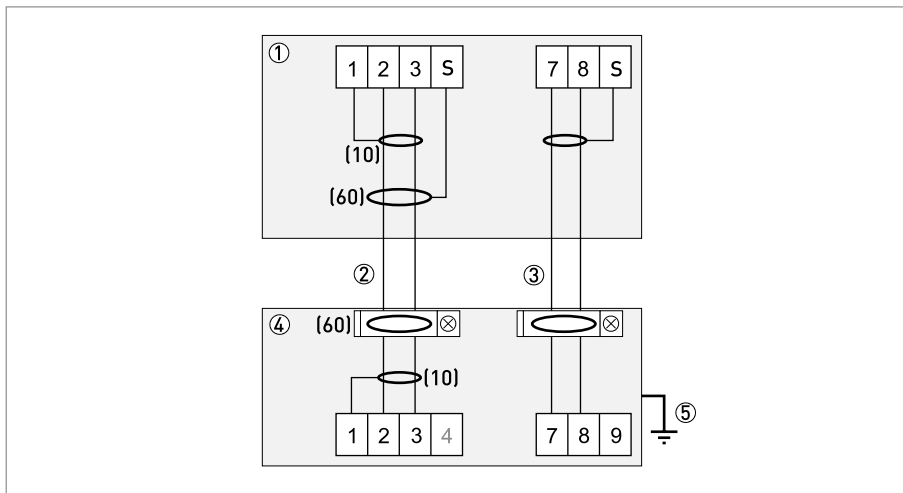

Figure 4-12: Connection diagram for signal and field current cable

- ① Electrical terminal compartment in the transmitter
- ② Signal cable A
- ③ Field current cable C
- ④ Electrical terminal compartment in the flow tube
- ⑤ Functional ground FE

4.6 Grounding the flow tube

4.6.1 Classical method

**CAUTION!**

There should be no difference in potential between the flow tube and the housing or protective earth of the transmitter!

- The flow tube must be properly grounded.
- The grounding cable should not transmit any interference voltages.
- Do not use the grounding cable to connect any other electrical devices to ground at the same time.
- The flow tubes are connected to ground by means of a functional grounding conductor FE.
- Special grounding instructions for the various flow tubes are provided in the separate documentation for the flow tube.
- The documentation for the flow tube also contain descriptions on how to use grounding rings and how to install the flow tube in metal or plastic pipes or in pipes which are coated on the inside.

4.7 Connecting the power supply



DANGER!

The device must be grounded in accordance with regulations in order to protect personnel against electric shocks.

- The housings of the devices, which are designed to protect the electronic equipment from dust and moisture, should be kept well closed at all times. Creepage distances and clearances are dimensioned to VDE 0110 and IEC 60664 for pollution severity 2. Supply circuits are designed for overvoltage category III and the output circuits for overvoltage category II.
- Fuse protection ($I_N \leq 16\text{ A}$) for the infeed power circuit, and also a separator (switch, circuit breaker) to isolate the transmitter must be provided.

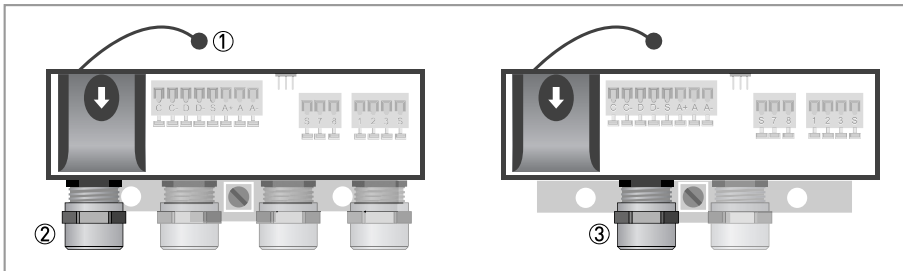

Figure 4-13: Terminal compartment for power supply

- ① Retaining band of the cover
- ② Cable entry for power supply, remote version
- ③ Cable entry for power supply, compact version

Version	Non-Ex	Ex
100...230 VAC	Standard	Optional
24 VDC	Standard	-
24 VAC/DC	Standard	Optional

Table 4-3: Version overview



- Open the cover of the electrical terminal compartment by pressing down and pulling forwards at the same time.

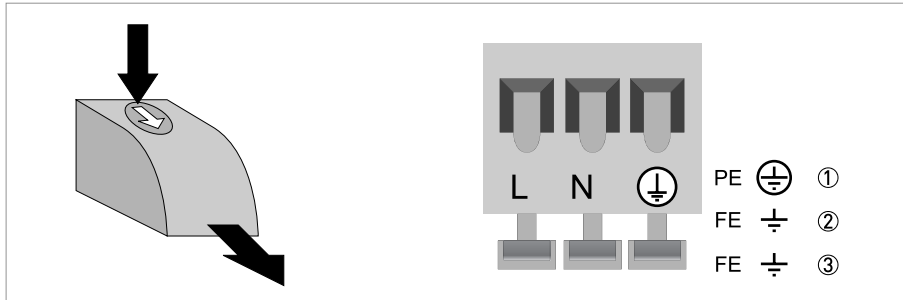

Figure 4-14: Power supply connection

- ① 100...230 VAC (-15% / +10%), 8 VA
- ② 24 VDC (-55% / +30%), 4 W
- ③ 24 VAC/DC (AC: -15% / +10%; DC: -25% / +30%), 7 VA or 4 W



- Close the cover after the power has been connected.

100...230 VAC (tolerance range for 100 VAC: -15% / +10%)

- Note the power supply voltage and frequency (50...60 Hz) on the nameplate.



NOTICE!

240 VAC + 5% is included in the tolerance range.

24 VDC (tolerance range: -55% / +30%)

- Note the data on the nameplate!
- When connecting to functional extra-low voltages, provide a facility for protective separation (PELV) (according to VDE 0100 / VDE 0106 and/or IEC 60364 / IEC 61140 or relevant national regulations).



NOTICE!

12 VDC - 10% is included in the tolerance range.

24 VAC/DC (tolerance range: AC: -15% / +10%; DC: -25% / +30%)

- AC: Note the power supply voltage and frequency (50...60 Hz) on the nameplate.
- AC/DC: When connecting to functional extra-low voltages, provide a facility for protective separation (PELV) (according to VDE 0100 / VDE 0106 and/or IEC 60364 / IEC 61140 or relevant national regulations).



NOTICE!

12 V is **not** included in the tolerance range.

4.8 Inputs and outputs, overview

4.8.1 Description of the CG number

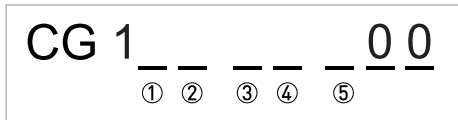

Figure 4-15: Marking (CG number) of the electronics module and output variants

- ① ID number: 0
- ② ID number: 0 = standard; 9 = special
- ③ Power supply
- ④ Display (language versions)
- ⑤ Input/output version (I/O)

4.8.2 Fixed, non-alterable input/output versions

This transmitter is available with various input/output combinations.

- The grey boxes in the tables denote unassigned or unused connection terminals.
- In the table, only the final digits of the CG no. are depicted.

CG no.	Connection terminals							
	C	C-	D	D-	S	A+	A	A-
1 0 0	S _p / C _p ①		P _p / S _p passive ①		②		I _p + HART® passive ③	
						I _a + HART® active ③		

Table 4-4: Fixed, non-alterable input/output versions

- ① Function change by software
- ② Shielding
- ③ Function changed by reconnecting

I _a	I _p	Current output active or passive
P _p		Pulse/frequency output passive
S _p		Status output / limit switch passive
C _p		Control input passive

Table 4-5: Description of used abbreviations

4.9 Description of the inputs and outputs

4.9.1 Current output

- All outputs are electrically isolated from each other and from all other circuits.
- All operating data and functions can be adjusted.
- Passive mode:
External power $U_{\text{ext}} \leq 32 \text{ VDC}$ at $I \leq 22 \text{ mA}$
- Active mode:
Load impedance $R_L \leq 750 \Omega$ at $I \leq 22 \text{ mA}$
- Self-monitoring: interruption or load impedance too high in the current output loop
- Error message possible via status output, error indication on LC display.
- Current value error detection can be adjusted.
- Automatic range conversion via threshold. The setting range for the threshold is between 5 and 80% of $Q_{100\%}$, $\pm 0...5\%$ hysteresis (corresponding ratio from smaller to larger range of 1:20 to 1:1.25).
Signaling of the active range possible via a status output (adjustable).
- Forward/reverse flow measurement (F/R mode) is possible.

**NOTICE!**

For further information refer to Connection diagrams of outputs on page 43.

**DANGER!**

For devices used in hazardous areas, additional safety notes apply; please refer to the Ex documentation.

4.9.2 Pulse output and frequency output

- All outputs are electrically isolated from each other and from all other circuits.
- All operating data and functions can be adjusted.
- Passive mode:
External power supply required: $U_{\text{ext}} \leq 32 \text{ VDC}$

$I \leq 20 \text{ mA}$ at $f \leq 10 \text{ kHz}$ (over range up to $f_{\text{max}} \leq 12 \text{ kHz}$)

$I \leq 100 \text{ mA}$ at $f \leq 100 \text{ Hz}$

- Scaling:
Frequency output: in pulses per time unit (e.g. 1000 pulses/s at $Q_{100\%}$);
Pulse output: quantity per pulse.
- Pulse width:
symmetric (pulse duty factor 1:1, independent of output frequency)
automatic (with fixed pulse width, duty factor approx. 1:1 at $Q_{100\%}$)
fixed (pulse width adjustable as required from 0.05 ms...2 s)
- Forward/reverse flow measurement (F/R mode) is possible.
- The pulse output and frequency output can also be used as a status output / limit switch.

**NOTICE!**

For further information refer to Connection diagrams of outputs on page 43.

**DANGER!**

For devices used in hazardous areas, additional safety notes apply; please refer to the Ex documentation.

4.9.3 Status output and limit switch

- The status outputs / limit switches are electrically isolated from each other and from all other circuits.
- The output stages of the status outputs / limit switches behave like relay contacts.
- All operating data and functions can be adjusted.
- Passive mode:
External power supply required: $U_{\text{ext}} \leq 32 \text{ VDC}$; $I \leq 100 \text{ mA}$
- For information on the adjustable operating states refer to *Function tables* on page 58.

**NOTICE!**

For further information refer to Connection diagrams of outputs on page 43.

**DANGER!**

For devices used in hazardous areas, additional safety notes apply; please refer to the Ex documentation.

4.9.4 Control input

**NOTICE!**

Which I/O version and inputs/outputs are installed in your transmitter are indicated on the sticker in the cover of the terminal compartment.

- All control inputs are electrically isolated from each other and from all other circuits.
- All operating data and functions can be adjusted.
- Passive mode:
External power supply required: $U_{\text{ext}} \leq 32 \text{ VDC}$
- For information on the adjustable operating states refer to *Function tables* on page 58.

**NOTICE!**

*For further information refer to *Connection diagrams of outputs* on page 43 and refer to *Technical data* on page 87.*

4.10 Electrical connection of the outputs



NOTICE!

Assembly materials and tools are not part of the delivery. Use the assembly materials and tools in compliance with the applicable occupational health and safety directives.

4.10.1 Electrical connection of the outputs



DANGER!

All work on the electrical connections may only be carried out with the power disconnected. Take note of the voltage data on the nameplate!

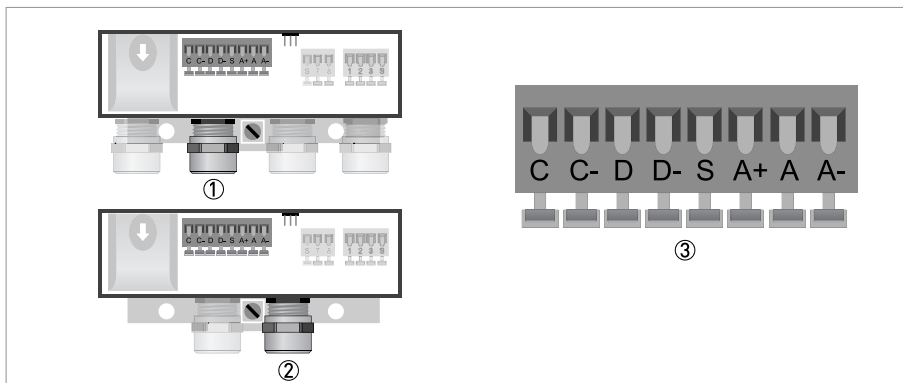

Figure 4-16: Connection of outputs

- ① Cable entry, remote version
- ② Cable entry, compact version
- ③ Terminal S for shield



- Open the housing cover
- Push the prepared cables through the cable entries and connect the necessary conductors.
- Connect the shield.
- Close the housing cover.



NOTICE!

Ensure that the housing gasket is properly fitted, clean and undamaged.

4.10.2 Laying electrical cables correctly

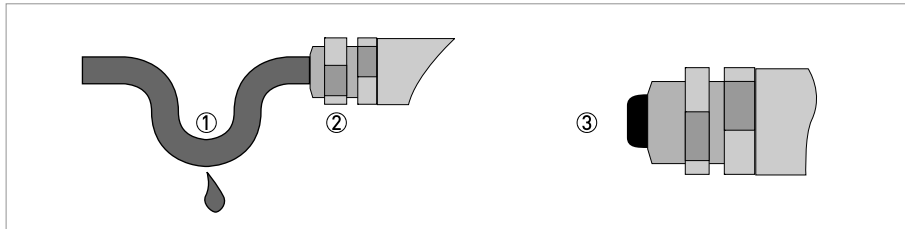

Figure 4-17: Protect housing from dust and water



- ① For compact versions with nearly horizontally-oriented cable entries, lay the necessary electric cables with a drip loop as shown in the illustration.
- ② Tighten the screw connection of the cable entry securely.
- ③ Seal cable entries that are not needed with a plug.

4.11 Connection diagrams of outputs

4.11.1 Important notes

- All groups are electrically isolated from each other and from all other output circuits.
- Passive mode: An external power supply is necessary to operate (activation) the subsequent devices (U_{ext}).
- Active mode: The transmitter supplies the power for operation (activation) of the subsequent devices, observe max. operating data.
- Terminals that are not used should not have any conductive connection to other electrically conductive parts.



DANGER!

For devices used in hazardous areas, additional safety notes apply; please refer to the Ex documentation.

I_a	I_p	Current output active or passive
P_p		Pulse/frequency output passive
S_p		Status output / limit switch passive
C_p		Control input passive

Table 4-6: Description of the used abbreviations

4.11.2 Description of the electrical symbols



	mA meter 0...20 mA or 4...20 mA and other R_L is the internal resistance of the measuring point including the cable resistance
	DC voltage source (U_{ext}), external power supply, any connection polarity
	DC voltage source (U_{ext}), observe connection polarity according to connection diagrams
	Internal DC voltage source
	Controlled internal power source in the device
	Electronic or electromagnetic counter At frequencies above 100 Hz, shielded cables must be used to connect the counters. R_i Internal resistance of the counter
	Button, N/O contact or similar

Table 4-7: Description of the electrical symbols

4.11.3 Basic inputs/outputs

**CAUTION!**

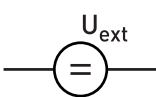
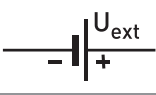
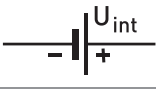
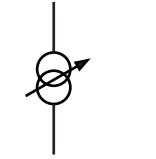
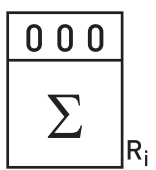
Observe connection polarity.

**NOTICE!**

For further information refer to *Description of the inputs and outputs on page 38* and refer to *HART connection on page 50*.

Current output active (HART®)

- $U_{\text{int, nom}} = 20 \text{ VDC}$
- $I \leq 22 \text{ mA}$
- $R_L \leq 750 \Omega$
- HART® at connection terminals A

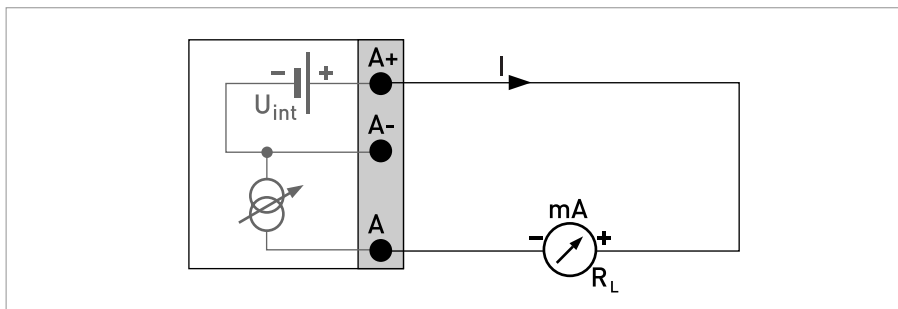

Figure 4-18: Current output active I_a

Current output passive (HART®)

- $U_{\text{int, nom}} = 20 \text{ VDC}$
- $U_{\text{ext}} \leq 32 \text{ VDC}$
- $I \leq 22 \text{ mA}$
- $U_0 \geq 2 \text{ V}$ at $I = 22 \text{ mA}$
- $R_L \leq (U_{\text{ext}} - U_0) / I_{\text{max}}$
- HART® at connection terminals A

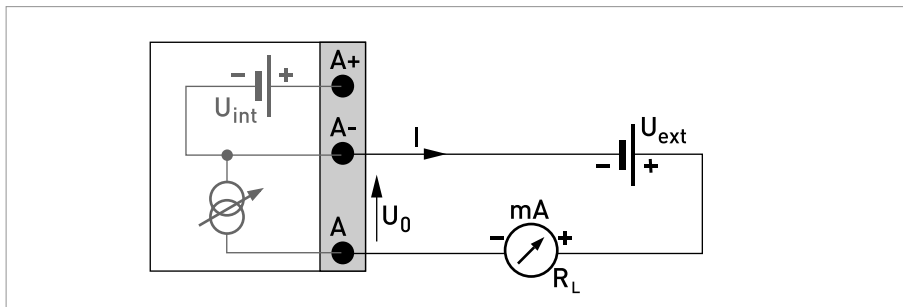

Figure 4-19: Current output passive I_p

**NOTICE!**

- Shielding takes place at the electrical connection (S) of the output terminal block.
- Any connection polarity.

Pulse/frequency output passive

- $U_{\text{ext}} \leq 32 \text{ VDC}$
- f_{max} in the operating menu set to $f_{\text{max}} \leq 100 \text{ Hz}$:
 $I \leq 100 \text{ mA}$
 $R_L \leq 47 \text{ k}\Omega$
 closed:
 $U_0 \leq 0.2 \text{ V}$ at $I = 10 \text{ mA}$
 $U_0 \leq 2 \text{ V}$ at $I = 100 \text{ mA}$
 open:
 $I \leq 0.05 \text{ mA}$ at $U_{\text{ext}} = 32 \text{ V}$
- f_{max} in operating menu set to $100 \text{ Hz} < f_{\text{max}} \leq 10 \text{ kHz}$:
 (over range up to $f_{\text{max}} \leq 12 \text{ kHz}$)
 $I \leq 20 \text{ mA}$
 $R_L \leq 10 \text{ k}\Omega$ for $f \leq 1 \text{ kHz}$
 $R_L \leq 1 \text{ k}\Omega$ for $f \leq 10 \text{ kHz}$
 closed:
 $U_0 \leq 1.5 \text{ V}$ at $I = 1 \text{ mA}$
 $U_0 \leq 2.5 \text{ V}$ at $I = 10 \text{ mA}$
 $U_0 \leq 5 \text{ V}$ at $I = 20 \text{ mA}$
 open:
 $I \leq 0.05 \text{ mA}$ at $U_{\text{ext}} = 32 \text{ V}$
- The minimum load impedance $R_{L, \text{min}}$ is calculated as follows:

$$R_{L, \text{min}} = (U_{\text{ext}} - U_0) / I_{\text{max}}$$
- Can also be set as status output; for the electrical connection refer to status output connection diagram.
- The output is open if the device is de-energised.

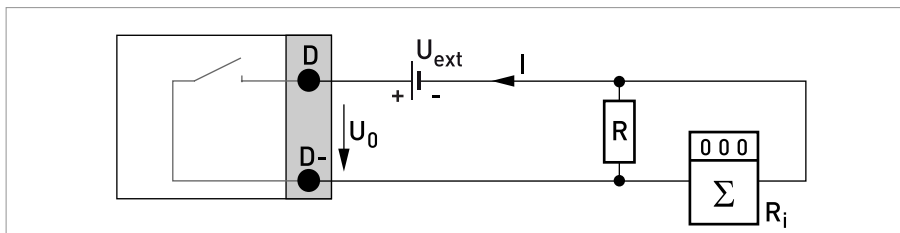
Figure 4-20: Pulse/frequency output passive P_p

**NOTICE!**

Any connection polarity.

Status output / limit switch passive

- $U_{\text{ext}} \leq 32 \text{ VDC}$
- $I \leq 100 \text{ mA}$
- $R_L = 47 \text{ k}\Omega$
closed:
 $U_0 \leq 0.2 \text{ V}$ at $I = 10 \text{ mA}$
 $U_0 \leq 2 \text{ V}$ at $I = 100 \text{ mA}$
open:
 $I \leq 0.05 \text{ mA}$ at $U_{\text{ext}} = 32 \text{ V}$
- The output is open if the device is de-energised.

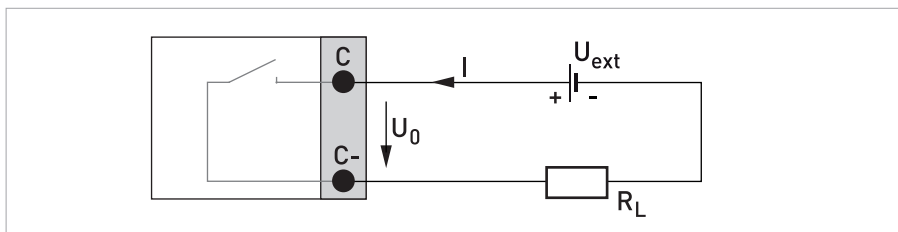

Figure 4-21: Status output / limit switch passive S_p

**NOTICE!**

- Any connection polarity.

Control input passive

- $U_{\text{ext}} \leq 32 \text{ VDC}$
- $I_{\text{nom}} = 6.5 \text{ mA}$ at $U_{\text{ext}} = 24 \text{ VDC}$
 $I_{\text{nom}} = 8.2 \text{ mA}$ at $U_{\text{ext}} = 32 \text{ VDC}$
- Switching point for identifying "contact open or closed":
 Contact open (off): $U_0 \leq 2.5 \text{ V}$ at $I_{\text{nom}} = 0.4 \text{ mA}$
 Contact closed (on): $U_0 \geq 8 \text{ V}$ at $I_{\text{nom}} = 2.8 \text{ mA}$
- Can also be set as a status output; for the electrical connection refer to status output connection diagram.

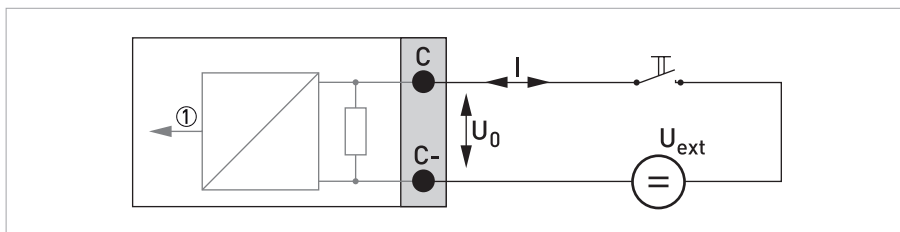

Figure 4-22: Control input passive C_p

① Signal

4.11.4 HART connection

**NOTICE!**

The current output always has HART[®] capability.

- Basic I/O: connection terminals A+/A-/A

All HART[®] connections (point-to-point and multi-drop operation) both work actively and passively.

Example for active HART[®] connection (point-to-point)

Figure 4-23: HART[®] connection active [I_a]

① HART[®] communicator

The parallel resistance to the HART[®] communicator must be $R \geq 230 \Omega$.

Example for passive HART[®] connection (multi-drop mode)

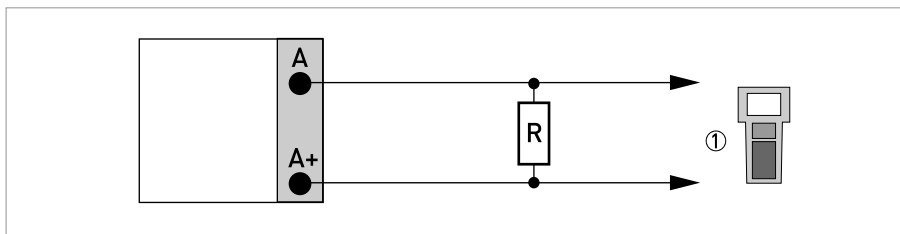
- $I: I_{0\%} \geq 4 \text{ mA}$
- Multi-drop mode $I: I_{\text{fix}} \geq 4 \text{ mA} = I_{0\%}$
- $U_{\text{ext}} \leq 32 \text{ VDC}$
- $R \geq 230 \Omega$

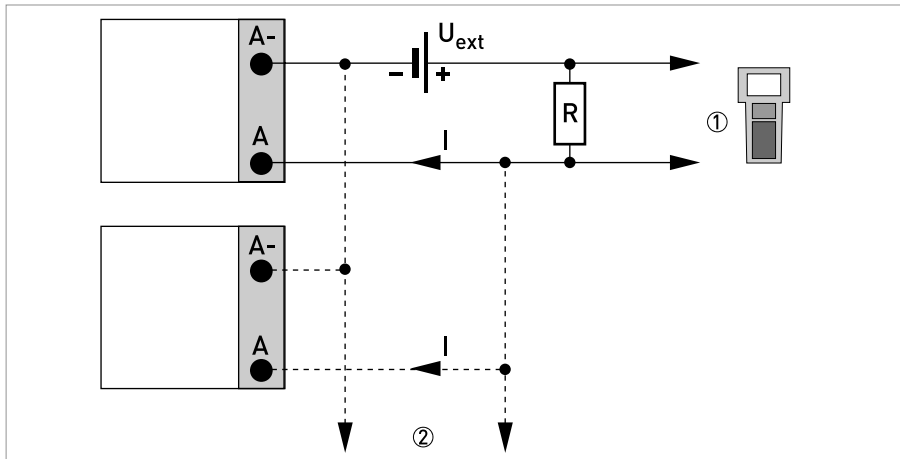

Figure 4-24: HART[®] connection passive [I_p]

- ① HART[®] communicator
- ② Other devices with HART[®] capability

5.1 Switching on the power

Before connecting to power, please check that the system has been correctly installed. This includes:

- The device must be mechanically safe and mounted in compliance with the regulations.
- The power connections must have been made in compliance with the regulations.
- The electrical terminal compartments must be secured and the covers have been screwed on.
- Check that the electrical operating data of the power supply are correct.



- Switching on the power.

5.2 Starting the transmitter

The measuring device, consisting of the flow tube and the transmitter, is supplied ready for operation. All operating data have been set at the factory in accordance with your order specifications.

When the power is switched on, a self test is carried out. After that the device immediately begins measuring, and the current values are displayed.

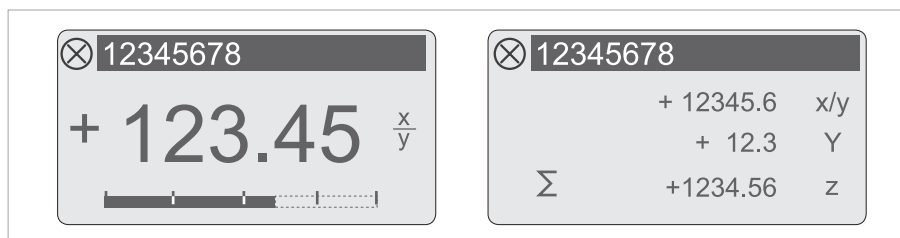

Figure 5-1: Displays in measuring mode (examples for 2 or 3 measured values)
x, y and z denote the units of the measured values displayed

It is possible to change between the two measured value windows, the trend display and the list with the status messages by pressing the keys \uparrow and \downarrow . For information about possible status messages, their meaning and cause refer to *Status messages and diagnostic information* on page 78.

6.1 Display and operating elements

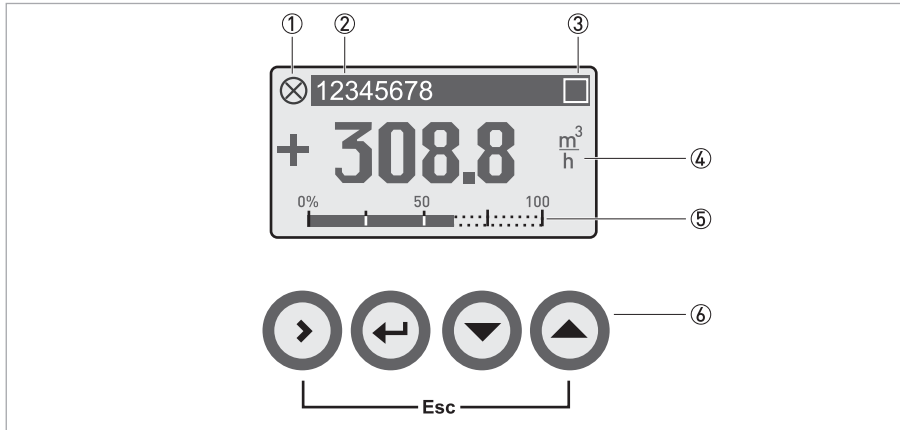

Figure 6-1: Display and operating elements (Example: flow indication with 2 measuring values)

- ① Indicates a possible status message in the status list
- ② Tag number (is only indicated if this number was entered previously by the operator)
- ③ Indicates when a key has been pressed
- ④ 1st measured variable in large representation
- ⑤ Bargraph indication
- ⑥ Keys (see table below for function and representation in text)



NOTICE!

- After 5 minutes of inactivity, there is an automatic return to measuring mode. Previously changed data is not saved.

Key	Measuring mode	Menu mode	Submenu or function mode	Parameter and data mode
>	Switch from measuring mode to menu mode; press key for 2.5 s, "A quick setup" menu is then displayed	Access to displayed menu, then 1st submenu is displayed	Access to displayed submenu or function	For numerical values, move cursor (highlighted in blue) one position to the right
←	Reset of display	Return to measuring mode but prompt whether the data should be saved	Press 1 to 3 times, return to menu mode, data saved	Return to submenu or function, data saved
↓ or ↑	Switch between display pages: measured value 1 + 2, trend page and status page	Select menu	Select submenu or function	Use cursor highlighted in blue to change number, unit, property and to move the decimal point
Esc (> + ↑)	-	-	Return to menu mode without acceptance of data	Return to submenu or function without acceptance of data

Table 6-1: Description of key functionality

6.1.1 Display in measuring mode with 2 or 3 measured values

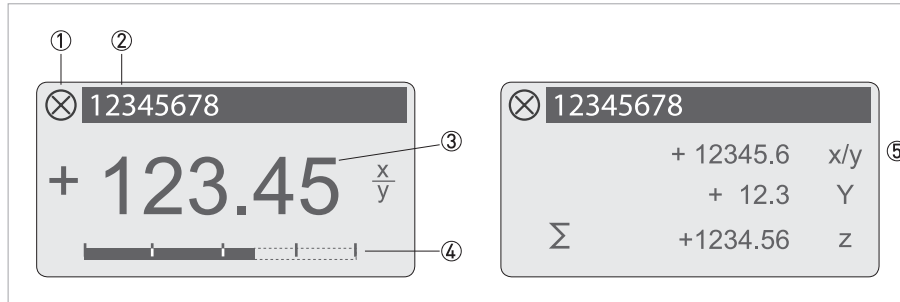

Figure 6-2: Example for display in measuring mode with 2 or 3 measured values

- ① Indicates a possible status message in the status list
- ② Tag number (is only indicated if this number was entered previously by the operator)
- ③ 1st measured variable in large representation
- ④ Bargraph indication
- ⑤ Depiction with 3 measured values

6.1.2 Display for selection of submenu and functions, 3 lines

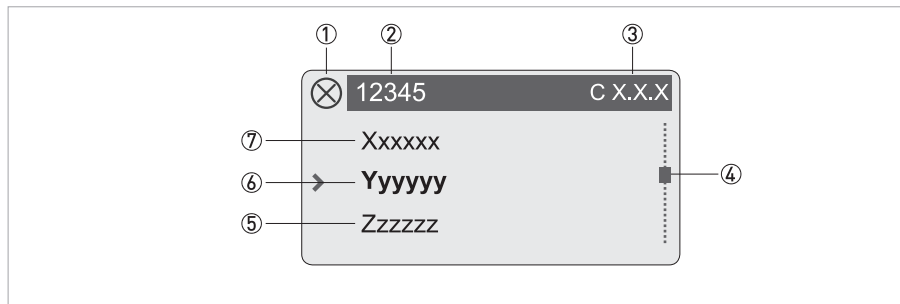

Figure 6-3: Display for selection of submenu and functions, 3 lines

- ① Indicates a possible status message in the status list
- ② Menu, submenu or function name
- ③ Number relating to ⑥
- ④ Indicates position within menu, submenu or function list
- ⑤ Next menu(s), submenu or function
[__ _ signalise in this line the end of the list]
- ⑥ Current menu(s), submenu or function
- ⑦ Previous menu(s), submenu or function
[__ _ signalise in this line the beginning of the list]

6.1.3 Display when setting parameters, 4 lines

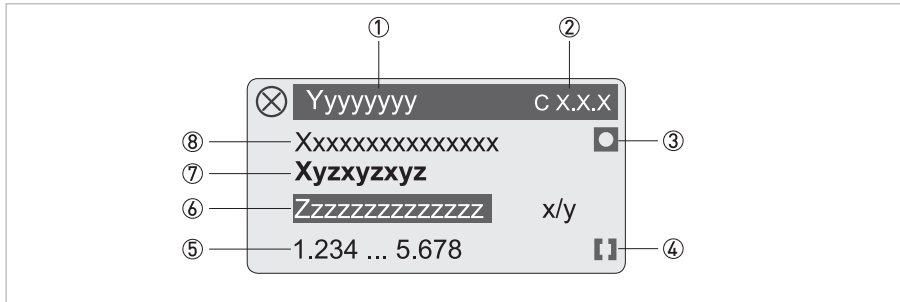

Figure 6-4: Display when setting parameters, 4 lines

- ① Current menu(s), submenu or function
- ② Number relating to ⑦
- ③ Denotes factory setting
- ④ Denotes permissible value range
- ⑤ Permissible value range for numeric values
- ⑥ Currently set value, unit or function (when selected, appears with white text, blue background)
This is where the data is changed.
- ⑦ Current parameter
- ⑧ Factory setting of parameter

6.1.4 Display when previewing parameters, 4 lines

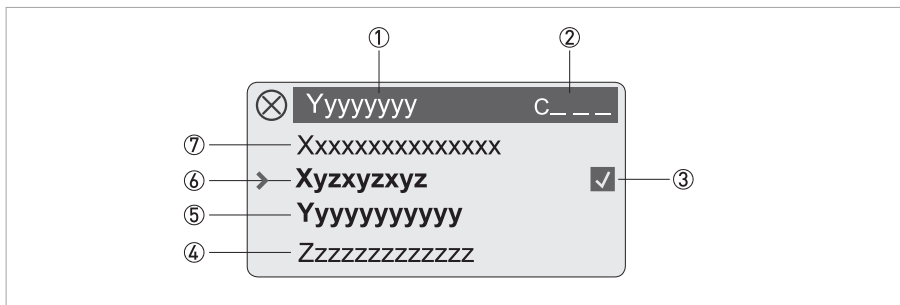

Figure 6-5: Display when previewing parameters, 4 lines

- ① Current menu(s), submenu or function
- ② Number relating to ⑥
- ③ Denotes a changed parameter (simple check of changed data when browsing through lists)
- ④ Next parameter
- ⑤ Currently set data from ⑥
- ⑥ Current parameter (for selection press key >; then see previous chapter)
- ⑦ Factory setting of parameter

6.2 Menu structure



NOTICE!

- The menu structure for the standard device (HART®) is described.
- Note the key function within and between the columns.

Measuring mode	Select menu	Select menu and/or submenu	Select function and set data
←	Press > 2.5 s		
	A quick setup	> A1 language <← > A2 tag <← > A3 reset <← > A4 analogue outputs <← > A5 digital outputs <← > A7 process input <←	> - <← > - <← > A3.1 reset errors A3.2 counter 1 A3.3 counter 2 > A4.1 measurement <← A4.2 unit A4.3 range A4.4 low flow cutoff A4.5 time constant > A5.1 measurement <← A5.2 pulse value unit A5.3 value p. pulse A5.4 low flow cutoff > A7.1 device serial no. <← A7.2 zero calibration A7.3 size A7.5 GKL A7.6 coil resistance Rsp A7.7 calib. coil temp. A7.8 target conduct. A7.9 EF electr. factor A7.10 field frequency A7.11 flow direction
←	B test	> B1 simulation <← B2 actual values B3 information	> Submenus on page 60 <←
	↓↑	↓↑	↓↑ >

Table 6-2: Menu structure "A quick setup" and "B test"

Measuring mode		Select menu	Select menu and/or submenu	Select function and set data
		↓ ↑	↓ ↑	↓ ↑ >
←	Press > 2.5 s			
	C setup	> ←	C1 process input	> ←
			C1.1 calibration	
			C1.2 filter	
			C1.3 self test	
			C1.4 information	
			C1.5 simulation	
←		> ←	C2 I/O (Input/Output)	> ←
			C2.1 hardware	
			C2._ current output X	
			C2._ frequency out X	
			C2._ pulse output X	
			C2._ status output X	
			C2._ control input X	
			C2._ limit switch X	
←		> ←	C3 I/O counter	> ←
			C3.1 counter 1	
			C3.2 counter 2	
←		> ←	C4 I/O HART	> ←
			C4.1 PV is	
			C4.2 SV is	
			C4.3 TV is	
			C4.4 4V is	
			C4.5 HART units	
←		> ←	C5 device	> ←
			C5.1 device info	
			C5.2 display	
			C5.3 1. meas. page	
			C5.4 2. meas. page	
			C5.5 graphic page	
			C5.6 special functions	
			C5.7 units	
			C5.8 HART	
			C5.9 quick setup	
	↓↑		↓↑	↓↑>

Table 6-3: Menu structure "C setup"

6.3 Function tables



NOTICE!

- The following tables describe the functions of the standard device with HART[®] connection.
- Depending on the device version, not all functions are available.

6.3.1 Menu "A quick setup"

Function	Setting / Description
----------	-----------------------

A1 language

A1 language	Language selection depends on the device version.
-------------	---

A2 tag

A2 tag	Measuring point identifier (Tag no.) appears in the LC display header (up to 8 digits).
--------	---

A3 reset?

A3 reset?	Reset error or counter.
A3.1 reset errors	Query: reset errors? Select: no / yes
A3.2 reset counter 1	Query: reset counter? Select: no / yes (available if activated in C5.9.1)
A3.3 reset counter 2	Query: reset counter? Select: no / yes (available if activated in C5.9.2)

A4 analogue outputs

A4 analogue outputs	Applicable to current output (terminal A or C), frequency output (terminal D), limit switch (terminal C and/or D) and the 1st display page / line 1
A4.1 measurement	Select: volume flow / mass flow / diagnosis value / flow speed / coil temperature / conductivity
	Query: Use at all outputs? (also use this setting for A4.2...A4.5!) Select: no (applies only to the main current output) / yes (applies to all analogue outputs)
A4.2 units	Selection of the unit from a list, depending on the "measurement".
A4.3 range	Setting for main current output (range: 0...100%). Setting: 0...x.xx (format and unit, depending on "measurement", see A4.1 and A4.2 above)
	Query: Use for all outputs? Make setting, see A4.1 above!
A4.4 low flow cutoff	Setting for main current output (sets output value to "0"). Setting: x.xxx ± x.xxx L/h (range: 0.0...20 L/h) (1st value = switching point / 2nd value = hysteresis), condition: 2nd value ≤ 1st value
	Query: Use for all outputs? Make setting, see A4.1 above!
A4.5 time constant	Setting for main current output (applicable to all flow measurements). Setting: xxx.x s (range: 000.1...100 s)
	Query: Use for all outputs? Make setting, see A4.1 above!

Function	Setting / Description
----------	-----------------------

A5 digital outputs

A5 digital outputs	Valid for pulse output (terminal D) and counter 1.
A5.1 measurement	Select: volume flow / mass flow Query: Use for all outputs? (also use this setting for A5.2...A5.4!) Select: no (only for pulse output D) / yes (for all digital outputs)
A5.2 pulse value unit	Selection of the unit from a list, depending on the "measurement".
A5.3 value p. pulse	Setting for pulse output D (volume or mass value per pulse). Setting: xxx.xxx in L or kg or in the unit selected in A5.2 Query: Use for all outputs? Make setting, see A5.1 above!
A5.4 low flow cutoff	Setting for pulse output D (sets output value to "0"). Setting: x.xxx ± x.xxx L/h (range: 0.0...20 L/h) [1st value = switching point / 2nd value = hysteresis], condition: 2nd value ≤ 1st value Query: Use for all outputs? Make setting, see A5.1 above!

A7 process input

A7.1 device serial no.	Shows the serial number of the system.
The following process input parameters are only available, if the quick access has been activated in the menu "setup / device / quick setup".	
A7.2 zero calibration	Display of actual zero calibration value. Query: calibrate zero? For settings refer to C1.1.1.
A7.3 size	Select from the size table.
A7.5 GKL	Set value acc. to information on nameplate; range: 0.5...20
A7.6 coil resistance Rsp	Field coil resistance at +20°C / +68°F; range: 10.00...220 Ω
A7.7 calib. coil temp.	The coil temperature is derived from the coil resistance at the reference temperature. For settings refer to C1.1.8.
A7.8 target conduct.	Reference value for on-site calibration; range: 1.000...50000 µS/cm
A7.9 EF electr. factor	For calculation of the conductivity based on the electrode impedance. For settings refer to C1.1.11.
A7.10 field frequency	Setting as on flow tube nameplate = line frequency x value (from the following list): 1/2; 1/4; 1/6; 1/8; 1/12; 1/18; 1/36; 1/50
A7.11 flow direction	Define the polarity of the flow direction. Select: normal direction (according to the arrow on the flow tube) / reverse direction (in the opposite direction to the arrow)

Table 6-4: Menu "A quick setup"

6.3.2 Menu "B test"

Function	Setting / Description
B1 simulation	
B1 simulation	The displayed values are simulated.
B1.1 flow speed	Simulation of the flow speed. Select: break (exit function without simulation) / set value (range: -12...+12 m/s; unit selection in C5.7.7) Query: start simulation? Select: no (exit function without simulation) / yes (start simulation)
B1.2 volume flow	Simulation of volume flow, sequence and settings similar to B1.1, see above!
B1._ current out X	_ stands for B1.3...1.6 Simulation X X stands for one of the connection terminals A, C or D Sequence and settings similar to B1.1, see above! For the pulse output the set number of pulses are displayed once in a second!
B1._ pulse output X	
B1._ frequency out X	
B1._ control input X	
B1._ limit switch X	
B1._ status output X	
B1._ status output X	
B2 actual values	
B2 actual values	Display of actual values. Exit the displayed function with the ← key.
B2.1 operating hours	Display the actual operating hours. Exit the displayed function with the ← key.
B2.2 act. flow speed	Display the actual flow speed. Exit the displayed function with the ← key.
B2.3 act. coil temp.	Refer also to C1.1.7...C1.1.8.
B2.4 electr. temperature	Display the actual electronics temperature. Exit the displayed function with the ← key.
B2.5 act. conductivity	Refer also to C1.3.1...C1.3.2.
B2.6 act. electr. noise	Refer also to C1.3.13...C1.3.15.
B2.8 act. coil resistance	Display the actual resistance of the field coils depending on the current coil temperature.
B3 information	
B3 information	LC display (this format description is only valid for B3.2....3.5 and B3.8) 1st line: ID number of the circuit board; 2nd line: software version; 3rd line: production date
B3.1 C number	CG number, cannot be changed (input/output version).
B3.2 process input	Process input part of the electronics.
B3.3 SW.REV.MS	Information about the main software.
B3.4 SW.REV.UIS	Information about the user interface software of the measuring device.
B3.6 device serial no.	Serial number of the system.
B3.7 electronic serial no.	Serial number of the electronics.
B3.8 Electronic Revision ER	Reference identification number, electronic revision and production date of the device; includes all hardware and software changes

Table 6-5: Menu "B test"

6.3.3 Menu "C setup"

Function	Setting / Description
C1 process input	
C1.1 calibration	
C1.1 calibration	Grouping of all functions related to flow tube calibration.
C1.1.1 zero calibration	Display of actual zero calibration value. Query: calibrate zero? Select: break (return with ← key) / standard (factory setting) / manual (display last value, set new value, range: -1.00...+1 m/s) / automatic (shows the current value as the new zero calibration value)
C1.1.2 size	Select from the size table.
C1.1.5 GKL	Set value acc. to the information on the nameplate. Range: 0.5...20
C1.1.7 coil resistance Rsp	Field coil resistance at +20°C / +68°F. Range: 10.00...220 Ω
C1.1.8 calib. coil temp.	The coil temperature is derived from the coil resistance at the reference temperature. Set coil temperature. Select: break (return with ← key) / standard (=+20°C / +68°F) / automatic (set current temperature) Range: -40.0...+200°C Set coil resistance. Select: break (return with ← key) / standard (= setting of C1.1.7) / automatic (= calibration with the current resistance)
C1.1.9 density	Calculation of the mass flow with constant product density. Range: 0.1...5 kg/L
C1.1.10 target conduct.	Reference value for on-site calibration. Range: 1.000...50000 µS/cm
C1.1.11 EF electr. factor	Factor for the calculation of the conductivity based on the electrode impedance. Query: calibrate EF? Select: break (return with ← key) / standard (with factory setting) / manual (set desired value) / automatic (determines EF according to the setting in C1.1.10)
C1.1.13 field frequency	Setting as on flow tube nameplate = line frequency x value (from the following list): 1/2; 1/4; 1/6; 1/8; 1/12; 1/18; 1/36; 1/50
C1.1.14 select settling	Mode of the settling time (special function). Select: standard (fixed allocation) / manual (manual time setting for the settling time for the field current)
C1.1.15 settling time	Only available if "manual" is selected in C1.1.14. Range: 1.0...250 ms
C1.1.16 line frequency	Setting the line frequency to one value. Select: 50 Hz or 60 Hz
C1.1.17 act. coil resistance	Display of the actual resistance of the field coil.

C1.2 filter

C1.2 filter	Grouping of all functions related to filter of flow tube electronics.
C1.2.1 limitation	Limitation of all flow values, before smoothing by time constant; affects all outputs.
	Settings: -xxx.x / +xxx.x m/s; condition: 1st value < 2nd value
	Range 1st value: -100.0 m/s ≤ value ≤ -0.001 m/s
	Range 2nd value: +0.001 m/s ≤ value ≤ +100 m/s
C1.2.2 flow direction	Define the polarity of the flow direction.
	Select: normal direction (according to the arrow on the flow tube) / reverse direction (in the opposite direction to the arrow)
C1.2.3 time constant	For all flow measurements and outputs.
	xxx.x s; range: 0.0...100 s
C1.2.4 pulse filter	Suppresses noise due to solids, air/gas bubbles and sudden changes in pH.
	Select: off (without pulse filter) / on (with pulse filter) / automatic (with new pulse filter)
	Pulse filter "on" : The change from one measurement value to the next one is limited to the value "pulse limitation" for the total time "pulse width". This filter allows a faster signal tracking for slowly changing flow values.
	Pulse filter "automatic" : The raw flow values are collected into a buffer, covering two times the "pulse width" values. This filter is called "median" filter. This filter allows a better suppression of pulse shaped disturbances (particles or air bubbles in very noisy environment).
C1.2.5 pulse width	Length of interference and delays to be suppressed on sudden changes in flow.
	Only available, if pulse filter (C1.2.4) is "on" or "automatic".
	xx.x s; range for "on": 0.01...10 s or for "automatic": 0.1...20 s
C1.2.6 pulse limitation	Dynamic limitation from one measured value to the next; only if pulse filter (C1.2.4) is "on".
	xx.x s; range: 0.01...100 m/s
C1.2.7 noise filter	Suppresses noise at low conductivity, high solids content, air and gas bubbles, and chemically inhomogeneous media.
	Select: off (without noise filter) / on (with noise filter)
C1.2.8 noise level	Range within which changes are evaluated as noise, and outside of which changes are evaluated as flow (only if the noise filter is set to "on" in C1.2.7).
	xx.xx m/s; range: 0.01...10 m/s
C1.2.9 noise suppression	Set noise suppression (only if the noise filter is set to "on" in C1.2.7).
	Range: 1...10; noise suppression factor [min = 1...max = 10]
C1.2.10 low flow cutoff	Sets low flow values to "0"; affects all outputs.
	x.xxx ± x.xxx L/h; range: 0.0...20 L/h
	[1st value = switching point / 2nd value = hysteresis], condition: 2nd value ≤ 1st value
C1.2.11 conductivity	Setting the time constant for the conductivity measurement. Only available, if the conductivity measurement is activated in C1.3.1.

C1.3 self test

C1.3 self test	Grouping of all functions related to self test of flow tube electronics.
C1.3.1 empty pipe	Switch conductivity measurement off and on (measurement of the electrode resistance with or without empty pipe detection).
	Select: off / conductivity (only conductivity measurement) / cond. + empty pipe (F) (conductivity measurement and empty pipe indication, error category [F] application) / cond. + empty pipe (S) (conductivity measurement and empty pipe indication, error category [S] measurement out of specification) / cond. + empty pipe (I) (conductivity measurement and empty pipe indication, error category [I] information)
	Flow indication "= 0" when "empty pipe"
C1.3.2 limit empty pipe	Only available if "empty pipe [..]" is activated in C1.3.1.
	Range: 0.0...9999 μ S (set about 50% of the lowest occurring conductivity in operation. Conductivity below this value means a signal as "empty pipe".
C1.3.3 act. conductivity	Only available if "empty pipe [..]" is activated in C1.3.1.
	Actual conductivity is indicated. Activation takes place only after setting mode is exited!
C1.3.13 electrode noise	Switch the automatic test off or on.
	Select: off / on
C1.3.14 limit electr. noise	Only available if electrode noise is activated in C1.3.13.
	Range: 0.000...12 m/s
	Noise above this threshold generates an error of category [S].
C1.3.15 act. electr. noise	Only available if electrode noise is activated in C1.3.13. Activation takes place only after setting mode is exited!
C1.3.16 settling of field	Automatic test switched off / on.
	Select: off / on
C1.3.17 diagnosis value	Select diagnosis value for testing the various analogue outputs.
	Select: off (no diagnosis) / electrode noise (activate in C1.3.13) / terminal 2 DC (electrode DC voltage at electrode terminal 2) / terminal 3 DC (electrode DC voltage at electrode terminal 3)

C1.4 information

C1.4 information	Grouping of all functions related to information with respect to flow tube and flow tube electronics.
C1.4.1 liner	Shows the material of the liner.
C1.4.2 electr. material	Shows the material of the electrodes.
C1.4.3 calibration date	Shows the date on which the flow tube was calibrated.
C1.4.4 serial no. sensor	Shows the serial number of the flow tube.
C1.4.5 V no. sensor	Shows the order number of the flow tube.
C1.4.6 sensor electr. info	Shows the serial number of the circuit board, the software version number and the calibration date of the circuit board.

C1.5 simulation

C1.5 simulation	Grouping of all functions for simulating flow tube values.
	These simulations have effect on all outputs, including counters and display.
C1.5.1 flow speed	For sequence refer to B1.1.
C1.5.2 volume flow	For sequence refer to B1.2.

Table 6-6: Menu C1

Function	Setting / Description
----------	-----------------------

C2 I/O (Inputs/Outputs)**C2.1 hardware**

C2.1 hardware	Configuration of connection terminals.
	Selection depends on transmitter version.
C2.1.1 terminals A	Select: off (switched off) / current output
C2.1.3 terminals C	Select: off (switched off) / current output / status output / limit switch / control input
C2.1.4 terminals D	Select: off (switched off) / frequency output / pulse output / status output / limit switch

C2._ current out X

C2._ current out X	X stands for connection terminals A
	_ stands for C2.2 (A)
C2._1 range 0%...100%	Current range for the selected "measurement", e.g. 4...20 mA, corresponds to 0...100%
	xx.x...xx.x mA; range: 0.00...20 mA Condition: $0 \text{ mA} \leq 1\text{st value} \leq 2\text{nd value} \leq 20 \text{ mA}$
C2._2 extended range	Min. and max. limits of current values. If the current range is exceeded, the current is set to these limits.
	xx.x ... xx.x mA; range: 03.5...21.5 mA Condition: $0 \text{ mA} \leq 1\text{st value} \leq 2\text{nd value} \leq 21.5 \text{ mA}$ and out of current range

Function	Setting / Description
C2._3 error current	Specify error current.
	xx.x mA; range: 3...22 mA Condition: outside of extended range
C2._4 error condition	Set the error conditions.
	Select: error in device [error category [F]] / application error [error category [F]] / out of specification [error category [F] & [S]]
C2._5 measurement	Measurements for activating the output.
	Select: volume flow / mass flow / diagnosis value / flow speed / coil temperature / conductivity
C2._6 range	0...100% of the "measurement" set in C2._5.
	x.xx...xx.xx __ __ (format and unit depend on the "measurement", see above)
C2._7 polarity	Set polarity; please note flow direction in C1.2.2!
	Select: both polarities (plus and minus values are displayed) / positive polarity [display for negative values = 0] / negative polarity [display for positive values = 0] / absolute value [always displays positive, with both negative and positive values]
C2._8 limitation	Limitation before applying the time constant.
	±xxx ... ±xxx%; range: -150...+150%
C2._9 low flow cutoff	Sets the measurement to "0" for low values.
	x.xxx ± x.xxx L/h; range: 0.0...20 L/h
	{1st value = switching point / 2nd value = hysteresis}; condition: 2nd value ≤ 1st value
C2._10 time constant	Range: 000.1...100 s
C2._11 special function	Select: off (switched off) / automatic range (range is changed automatically, extended lower range; the magnifying function in the extended lower range, only makes sense in combination with a status output)
C2._12 threshold	Appears only if "C2._11 threshold" is activated between extended and normal range. The automatic range function always changes from the extended to the normal range when the 100% current is reached. The upper 100% value of the hysteresis is then = 0. The threshold is then the hysteresis value, instead of "threshold ± hysteresis" as shown in the display.
	Range: 5.0...80%
	{1st value = switching point / 2nd value = hysteresis}; condition: 2nd value ≤ 1st value
C2._13 information	Serial number of the I/O board, software version number and production date of the circuit board.
C2._14 simulation	For sequence refer to "B1._ current output X".
C2._15 4mA trimming	Trimming of the current at 4 mA.
	Reset to 4 mA restores the factory calibration.
	Used for HART® setting.
C2._16 20mA trimming	Trimming of the current at 20 mA.
	Reset to 20 mA restores the factory calibration.
	Used for HART® setting.

C2._ frequency out X

C2._ frequency out X	X stands for connection terminals D _ stands for C2.5 (D)
C2._1 pulse shape	Specify the pulse shape. Select: symmetric (about 50% on and 50% off) / automatic (constant pulse with about 50% on and 50% off at 100% pulse rate) / fixed (fixed pulse rate; for setting refer to "C2._3 100% pulse rate")
C2._2 pulse width	Only available if set to "fixed" in C2._1. Range: 0.05...2000 ms Note: max. setting value T_p [ms] \leq 500 / max. pulse rate [1/s], gives the pulse width = time where the output is activated
C2._3 100% pulse rate	Pulse rate for 100% of the measuring range. Limitation is at 120% of this pulse rate or at $1/(1.5 * \text{pulse width})$ whatever is lower. Range: 1...10000 Hz
C2._4 measurement	Measurements for activating the output. Select: volume flow / mass flow / diagnosis value / flow speed / coil temperature / conductivity
C2._5 range	0...100% of the "measurement" set in C2._4 x.xx...xx.xx _ _ _ (format and unit depend on the "measurement", see above)
C2._6 polarity	Set polarity; please note flow direction in C1.2.2! Select: both polarities (plus and minus values are displayed) / positive polarity (display for negative values = 0) / negative polarity (display for positive values = 0) / absolute value (always displays positive, with both negative and positive values)
C2._7 limitation	Limitation before applying the time constant. \pm xxx ... \pm xxx%; range: -150...+150%
C2._8 low flow cutoff	Sets the measurement to "0" for low values. x.xxx \pm x.xxx L/h; range: 0.0...20 L/h [1st value = switching point / 2nd value = hysteresis]; condition: 2nd value \leq 1st value
C2._9 time constant	Range: 000.1...100 s
C2._10 invert signal	Select: off (activated output: switch closed) / on (activated output: switch open)
C2._12 information	Serial number of the I/O board, software version number and production date of the circuit board.
C2._13 simulation	For sequence refer to "B1._ frequency out X".

C2._ pulse output X

C2._ pulse output X	X stands for connection terminals D _ stands for C2.5 (D)
C2._1 pulse shape	Specify the pulse shape. Select: symmetric (about 50% on and 50% off) / automatic (constant pulse with about 50% on and 50% off at max. pulse rate) / fixed (fixed pulse rate, for setting refer to "C2._3 max. pulse rate")
C2._2 pulse width	Only available if set to "fixed" in C2._1. Range: 0.05...2000 ms Note: max. setting value T_p [ms] ≤ 500 / max. pulse rate [1/s], gives the pulse width = time where the output is activated For pulse widths below 0.5 seconds the max. pulse rate has to be adjusted to $1/(2 * \text{pulse width})$ to prevent overrange messages.
C2._3 max. pulse rate	Maximum pulse rate. Limitation is at 120% of this pulse rate or at $1/(1.5 * \text{pulse width})$ whatever is lower. Range: 1...10000 Hz
C2._4 measurement	Measurements for activating the output. Select: volume flow / mass flow
C2._5 pulse value unit	Selection of the unit from a list, depending on the "measurement".
C2._6 value p. pulse	Set value for volume or mass per pulse. xxx.xxx; measured value in L or kg depending on setting in C2._5
C2._7 polarity	Set polarity; please note flow direction in C1.2.2! Select: both polarities (plus and minus values are displayed) / positive polarity (display for negative values = 0) / negative polarity (display for positive values = 0) / absolute value (always displays positive, with both negative and positive values)
C2._8 low flow cutoff	Sets the measurement to "0" for low values. x.xxx \pm x.xxx L/h; range: 0.0...20 L/h [1st value = switching point / 2nd value = hysteresis]; condition: 2nd value \leq 1st value
C2._9 time constant	Range: 000.1...100 s
C2._10 invert signal	Select: off (activated output: switch closed) / on (activated output: switch open)
C2._12 information	Serial number of the I/O board, software version number and production date of the circuit board.
C2._13 simulation	For sequence refer to "B1._ pulse output X".

C2._ status output X

C2._ status output X	X (Y) stands for one of the connection terminals C or D _ stands for C2.4 (C) / C2.5 (D)
C2._1 mode	The output shows the following measuring conditions: Select: out of specification (output set, signals status of category "error in device" or "application error" or "out of specification" refer to <i>Status messages and diagnostic information</i> on page 78) / application error (output set, signals status of the category "error in device" or "application error" refer to <i>Status messages and diagnostic information</i> on page 78) / polarity flow (polarity of the current flow) / over range flow (over range of the flow) / counter 1 preset (activates when counter X preset value is reached) / counter 2 preset (activates when counter X preset value is reached) / output A (activated by the status of output Y, additional output data see below) / output C (activated by the status of output Y, additional output data see below) / output D (activated by the status of output Y, additional output data see below) / off (switched off) / empty pipe (when pipe empty, output activated) / error in device (output set, signals status of the category "error in device" refer to <i>Status messages and diagnostic information</i> on page 78)
C2._2 current output Y	Only appears if output A or C is set under "mode" and this output is a "current output". Select: polarity (is signalled) / over range (is signalled) / automatic range (signals lower range)
C2._2 frequency out Y and pulse output Y	Only appears if output D is set under "mode" and this output is a "frequency output" or "pulse output". Select: polarity (is signalled) / over range (is signalled)
C2._2 status output Y	Only appears if output C or D is set under "mode" and this output is a "status output". Select: same signal (like other connected status output, signal can be inverted, see below)
C2._2 limit switch Y	Only appears if output C or D is set under "mode" and this output is a "limit switch". Select: status off (is always selected here if "status output X" is connected with a limit switch)
C2._2 off	Only appears if output A, C or D is set under "mode" and this output is switched off.
C2._3 invert signal	Select: off (activated output: switch closed) / on (activated output: switch open)
C2._4 information	Serial number of the I/O board, software version number and production date of the circuit board.
C2._5 simulation	For sequence refer to "B1._ status output X".

C2._ limit switch X

C2._ limit switch X	X stands for one of the connection terminals C or D _ stands for C2.4 (C) / C2.5 (D)
C2._1 measurement	Select: volume flow / mass flow / diagnosis value / flow speed / coil temperature / conductivity
C2._2 threshold	Switching level, set threshold with hysteresis. xxx.x ±x.xxx (format and unit depending on the "measurement", see above) [1st value = threshold / 2nd value = hysteresis]; condition: 2nd value ≤ 1st value
C2._3 polarity	Set polarity; please note flow direction in C1.2.2! Select: both polarities (plus and minus values are displayed) / positive polarity (display for negative values = 0) / negative polarity (display for positive values = 0) / absolute value (always displays positive, with both negative and positive values)
C2._4 time constant	Range: 000.1...100 s
C2._5 invert signal	Select: off (activated output: switch closed) / on (activated output: switch open)
C2._6 information	Serial number of the I/O board, software version number and production date of the circuit board.
C2._7 simulation	For sequence refer to "B1._ limit switch X".

C2.4 control input C

C2.4.1 mode	Definition of the control input. off (control input switched off) / hold all outputs (hold current values, not display and counters) / output X (hold current values) / all outputs to zero (current values = 0%, not display and counters) / output X to zero (current value = 0%) / reset all counters (reset all counters to "0") / reset counter X (only counter X (1 or 2) is reset to "0") / stop all counters / stop counter X (stop only counter X (1 or 2) / zero outp.+stop Cnt. (all outputs to "0", stop all counters, not the display) / error reset (all resettable errors are deleted)
C2.4.2 invert signal	Select: off (control input is activated when a current is applied at the input (by voltage to passive inputs or a low-value resistor to active inputs)) / on (control input is activated when no current is applied at the input (low voltage to passive inputs or a high-value resistor to active inputs))
C2.4.3 information	Serial number of the I/O board, software version number and production date of the circuit board.
C2.4.4 simulation	For sequence refer to "B1._ control input X".

Table 6-7: Menu C2

Function	Setting / Description
C3 I/O counter (HART®)	
C3.1 counter 1	Set function of counter.
C3.2 counter 2	<p>_ stands for 1, 2 (= counter 1, 2)</p> <p>The basic version (standard) has only 2 counters! These functions are only available for HART® devices.</p>
C3._1 function	Select: sum counter (counts positive + negative values) / + counter (counts only the positive values) / - counter (counts only the negative values) / off (counter is switched off)
C3._2 measurement	<p>Selection of the "measurement" for counter _.</p> <p>Select: volume flow / mass flow</p>
C3._3 low flow cutoff	<p>Sets low flow values to "0".</p> <p>Range: 0.0...20%</p> <p>(1st value = switching point / 2nd value = hysteresis); condition: 2nd value ≤ 1st value</p>
C3._4 time constant	Range: 000.1... 100 s
C3._5 preset value	<p>If this value is reached, positive or negative, a signal is generated that can be used for a status output. For this status output the "counter X preset" has to be set.</p> <p>Preset value (max. 8 digits) x.xxxxx in selected unit; refer to C5.7.10 and C5.7.13</p>
C3._6 reset counter	For sequence refer to A3.2 and A3.3.
C3._7 set counter	<p>Set counter _ to the desired value.</p> <p>Select: break (exit function) / set value (opens the editor to make the entry)</p> <p>Query: set counter?</p> <p>Select: no (exit function without setting the value) / yes (sets the counter and exits the function)</p>
C3._8 stop counter	<p>Counter _ stops and holds the current value.</p> <p>Select: no (exit the function without stopping the counter) / yes (stop the counter and exits the function)</p>
C3._9 start counter	<p>Start counter _ after that counter is stopped.</p> <p>Select: no (exits the function without starting the counter) / yes (starts the counter and exits the function)</p>
C3._10 information	Serial number of the I/O board, software version number and production date of the circuit board.

Table 6-8: Menu C3

Function	Setting / Description
----------	-----------------------

C4 I/O HART

C4 I/O HART	<p>Selection or display of the 4 dynamic variables (DV) for HART®.</p> <p>The HART® current output (terminal A for basic I/O) always has a fixed link to the primary variables (PV).</p> <p>Fixed links of the other DVs (1-3) are only possible if one additional analogue output (frequency output) is available. If not, the "measurement" can be freely selected from the following list. Select: flow speed / volume flow / mass flow / diagnosis value / coil temperature / conductivity / counter 1 / counter 2 / operating hours</p> <p>X stands for connection terminals A, C and D</p> <p>_ stands for 1, 2, 3 or 4</p>
C4.1 PV is	Current output (primary variable)
C4.2 SV is	(secondary variable)
C4.3 TV is	(tertiary variable)
C4.4 4V is	(4th variable)
C4.5 HART units	<p>Function to make the change of the units for the DVs (dynamic variables) possible.</p> <p>Select: break (return with ← key) / HART® display (copies the settings for the display units to the settings for the DVs) / load defaults (resets the DVs to the factory defaults)</p>
C4._1 current output X	Shows the current analogue measured value of the linked current output. The "measurement" cannot be changed!
C4._1 frequency out X	Shows the current analogue measured value of the linked frequency output. The "measurement" cannot be changed!
C4._1 HART dynamic var.	<p>Measurements of the dynamic variables for HART®.</p> <p>Select: flow speed / volume flow / mass flow / diagnosis value / coil temperature / conductivity / counter 1 / counter 2 / operating hours</p>

Table 6-9: Menu C4

Function	Setting / Description
----------	-----------------------

C5 device

C5.1 device info

C5.1 device info	Grouping of all functions that have no direct effect on the measurement or any output.
C5.1.1 Tag	Settable characters (max. 8 digits): A...Z; a...z; 0...9; / - , .
C5.1.2 C number	CG number, cannot be changed; describes the transmitter version.
C5.1.3 device serial no.	Serial number of the system; cannot be changed.
C5.1.4 electronic serial no.	Serial number of the electronic assembly; cannot be changed.
C5.1.5 SW.REV.MS	Serial number of the circuit board, version number of the main software, production date of the circuit board.
C5.1.6 Electronic Revision ER	Reference identification number, electronic revision and production date of the device; includes all hardware and software changes.

C5.2 display

C5.2 display	-
C5.2.1 language	Language selection depends on the device version.
C5.2.2 contrast	At extreme temperatures the contrast on the display can be adjusted.
	Setting: -9...0...+9
	This change takes place immediately, not just when setting mode is exited!
C5.2.3 default display	Specification of the default display page that is returned to after a short delay period.
	Select: none (current page is always active) / 1. meas. page (shows this page) / 2. meas. page (shows this page) / status page (shows only status messages) / graphic page (trend of the 1st measurement)
C5.2.5 SW.REV.UIS	Serial number of the circuit board, version number of user interface software, production date of the circuit board.

C5.3 1. meas. page & C5.4 2. meas. page

C5.3 1. meas. page	_ stands for 3 = 1. meas. page and 4 = 2. meas. page
C5.4 2. meas. page	
C5._1 function	Specify the number of measured value lines (font size). Select: one line / two lines / three lines
C5._2 measurement 1.line	Specify the "measurement" for the 1st line. Select: volume flow / mass flow / diagnosis value / flow speed / coil temperature / conductivity
C5._3 range	0...100% of the "measurement" set in C5._2. x.xx...xx.xx _ _ _ (format and unit depending on the "measurement")
C5._4 limitation	Limitation before applying the time constant. ±xxx...±xxx%; range: -120...+120%
C5._5 low flow cutoff	Sets low flow values to "0". x.xxx ± x.xxx %; range: 0.0...20 % (1st value = switching point / 2nd value = hysteresis); condition: 2nd value ≤ 1st value
C5._6 time constant	Range: 0.1...100 s
C5._7 format 1.line	Specify decimal places. Select: automatic (adaptation is automatic) / X (= none) ...X.XXXXXXXXX (max. 8 digits)
C5._8 measurement 2.line	Specify "measurement 2.line" (only available if this 2nd line is activated) Select: bargraph (for the measurement selected in 1st line) / volume flow / mass flow / diagnosis value / flow speed / counter 1 / counter 2 / conductivity / coil temperature / operating hours
C5._9 format 2.line	Specify position after decimal point (only available if this 2nd line is activated). Select: automatic (adaptation is automatic) / X (= none) ...X.XXXXXXXXX (max. 8 digits)
C5._10 measurement 3.line	Specify "measurement 3.line" (only available if this 3rd line is activated). Select: volume flow / mass flow / diagnosis value / flow speed / counter 1 / counter 2 / conductivity / coil temperature / operating hours
C5._11 format 3.line	Specify position after decimal point (only available if this 3rd line is activated). Select: automatic (adaptation is automatic) / X (= none) ...X.XXXXXXXXX (max. 8 digits)

C5.5 graphic page

C5.5 graphic page	This page always shows trend curve of the "measurement" of the 1. meas. page / 1.line (refer to C5.3.2).
C5.5.1 select range	Select: manual (set range in C5.5.2) / automatic (automatic depiction based on the measured values) Reset only after parameter change or after switching off and on.
C5.5.2 range	Set the scaling for the Y axis. Only available if "manual" is set in C5.5.1. $\pm xxx \pm xxx\%$; range: -100...+100% (1st value = lower limit / 2nd value = upper limit); condition: 1st value \leq 2nd value
C5.5.3 time scale	Set the time scaling for the X axis (trend curve). xxx min; range: 0...100 min

C5.6 special functions

C5.6 special functions	-
C5.6.1 reset errors	Query: reset errors? Select: no / yes
C5.6.2 save settings	Save current settings. Select: break (exit function without saving) / backup 1 (saves the settings in the backup 1 storage place) / backup 2 (saves the settings in the backup 2 storage place) Query: go on with copy? (cannot be undone) Select: no (exit function without saving) / yes (copy current settings to storage backup 1 or backup 2)
C5.6.3 load settings	Load saved settings. Select: break (exit function without loading) / factory settings (reload factory settings) / backup 1 (loads the settings from the backup 1 storage place) / backup 2 (loads the settings from the backup 2 storage place) / load sensor data (restore factory setting of the values for the flow tube. Display and I/O settings are retained!) Query: go on with copy? (cannot be undone) Select: no (exit function without saving) / yes (load data from the selected storage place)
C5.6.4 password quick set	Password required to change data in the menu "quick setup". 0000 (= to this menu without password) xxxx (password required); range (4 digits): 0001...9999
C5.6.5 password setup	Password required to change data in the menu "setup". 0000 (= to this menu without password) xxxx (password required); range (4 digits): 0001...9999

C5.7 units

C5.7 units	-
C5.7.1 volume flow	m ³ /h; m ³ /min; m ³ /s; L/h; L/min; L/s (L = litres); cf/h; cf/min; cf/s; gal/h; gal/min; gal/s; IG/h; IG/min; IG/s; free unit (set factor and text in the next two functions, sequence see below)
C5.7.2 Text free unit	For text to be specified refer to <i>Set free units</i> on page 76:
C5.7.3 [m ³ /s]*factor	Specification of the conversion factor, based on m ³ /s: For text to be specified refer to <i>Set free units</i> on page 76:
C5.7.4 mass flow	kg/s; kg/min; kg/h; t/min; t/h; g/s; g/min; g/h; lb/s; lb/min; lb/h; ST/min; ST/h (ST = Short Ton); LT/h (LT = Long Ton); free unit (set factor and text in the next two functions, sequence see below)
C5.7.5 Text free unit	For text to be specified refer to <i>Set free units</i> on page 76:
C5.7.6 [kg/s]*factor	Specification of the conversion factor, based on kg/s: xxx.xxx refer to <i>Set free units</i> on page 76
C5.7.7 flow speed	m/s; ft/s
C5.7.8 conductivity	μS/cm; S/m
C5.7.9 temperature	°C; °F; K
C5.7.10 volume	m ³ ; L; hL; mL; gal; IG; in ³ ; cf; yd ³ ; free unit (set factor and text in the next two functions, sequence see below)
C5.7.11 Text free unit	For text to be specified refer to <i>Set free units</i> on page 76:
C5.7.12 [m ³]*factor	Specification of the conversion factor, based on m ³ : xxx.xxx refer to <i>Set free units</i> on page 76
C5.7.13 mass	kg; t; mg; g; lb; ST; LT; oz; free unit (set factor and text in the next two functions, sequence see below)
C5.7.14 Text free unit	For text to be specified refer to <i>Set free units</i> on page 76:
C5.7.15 [kg]*factor	Specification of the conversion factor, based on kg: xxx.xxx refer to <i>Set free units</i> on page 76
C5.7.16 density	kg/L; kg/m ³ ; lb/cf; lb/gal; free unit (set factor and text in the next two functions, sequence see below)
C5.7.17 Text free unit	For text to be specified refer to <i>Set free units</i> on page 76:
C5.7.18 [kg/m ³]*factor	Specification of the conversion factor, based on kg/m ³ : xxx.xxx refer to <i>Set free units</i> on page 76

C5.8 HART

C5.8 HART	This function is only available for devices with a HART® interface!
C5.8.1 HART	Switch the HART® communication on or off. Select: on (HART® activated); possible current range for current output 4...20 mA / off (HART® not activated); possible current range for current output 0...20 mA
C5.8.2 address	Set address for HART® operation. Select: 00 (point-to-point operation, current output has normal function) / 01...15 (Multi-Drop operation, current output is set to the 0% value)
C5.8.3 message	Set required text: A...Z ; a...z ; 0...9 ; / - + , . *
C5.8.4 description	Set required text: A...Z ; a...z ; 0...9 ; / - + , . *

C5.9 quick setup

C5.9 quick setup	Activate quick access in the menu "quick setup". Default: "quick setup" is active (yes) Select: yes (activated) / no (not activated)
C5.9.1 reset counter 1	Reset of counter 1 can be activated or deactivated. Select: yes (activated) / no (not activated)
C5.9.2 reset counter 2	Reset of counter 2 can be activated or deactivated. Select: yes (activated) / no (not activated)
C5.9.4 process input	Activate quick access to the important process input parameters. Select: yes (activated) / no (not activated)

Table 6-10: Menu C5

6.3.4 Set free units

Free units	Sequences to set texts and factors
Texts	
Volume flow, mass flow and density	3 digits before and after the slash xxx/xxx (max. 6 characters plus a "/")
Permissible characters	A...Z; a...z; 0...9; / - + , . *; @ \$ % ~ {} [] _
Conversion factors	
Desired unit	= [unit see above] * conversion factor
Conversion factor	Max. 9 digits
Shift decimal point	↑ to the left and ↓ to the right

Table 6-11: Sequences to set texts and factors

6.4 Description of functions

6.4.1 Reset counter in the menu "quick setup"



NOTICE!

It may be necessary to activate resetting of the counter in the menu "quick setup".

Key	Function	Description
>	A quick setup	Press and hold for 2.5 s, then release the key.
>	A1 language	-
2 x ↓	A3 reset	-
>	A3.1 reset errors	-
↓	A3.2 counter 1	Select desired counter.
↓	A3.3 counter 2	
>	Query: reset counter? Select: no	-
↓ or ↑	Query: reset counter? Select: yes	-
↵	A3.2 counter 1 or A3.3 counter 2	Counter has been reset.
3 x ↵	Measuring mode	-

Table 6-12: Reset counter in the menu "quick setup"

6.4.2 Deleting error messages in the menu "quick setup"

Key	Function	Description
>	A quick setup	Press and hold for 2.5 s, then release the key.
>	A1 language	-
2 x ↓	A3 reset	-
>	A3.1 reset errors	-
>	Query: reset errors? Select: no	-
↓ or ↑	Query: reset errors? Select: yes	-
↵	A3.1 reset errors	Error has been reset.
3 x ↵	Measuring mode	-

Table 6-13: Deleting error messages in the menu "quick setup"

6.5 Status messages and diagnostic information



NOTICE!

As status message always the name of the relevant status group and the status signal is displayed.

Each status message (= status signal) has a specific symbol, determined by NAMUR, which is displayed with the message. The length of each message is limited to one line.



Symbol	Symbol background colour	Letter	Status signal	Description and consequence
	white	F (bold)	Error in device	No measurement possible.
	blue	F	Application error	No measurement possible due to process/application conditions. The device is still OK.
	blue	S	Out of specification	Measurements are available but are no longer sufficiently accurate and should be checked.
	blue	C	Checks in progress	A test function is active. The displayed or transferred measured value does not correspond to the actual measured value.
-	-	I	Information	No direct influence on the measurements.

Table 6-14: Symbols for status messages

Messages on the display	Description	Actions
Status: F _ _ _ _ _	Operational fault in device, mA output \leq 3.6 mA or set fault current (depending on the seriousness of the fault), status output open, pulse / frequency output: no pulses	Repair necessary.
F error in device	Error or failure of device. Parameter or hardware error. No measurement possible.	Group message, when one of the following or some other severe error occurs.
F IO 1	Error, operational fault in IO 1. Parameter or hardware error. No measurement possible.	Load settings (C4.6.3) (backup 1, backup 2 or factory settings). If status message still does not disappear, replace electronic unit.
F parameter	Error, operational fault of data manager, electronic unit, parameter or hardware error. Parameters no longer usable.	
F configuration	Invalid configuration: display software, bus parameter or main software do not match existing configuration.	If device configuration unchanged: defective, replace electronic unit.
F display	Error, operational fault in the display. Parameter or hardware error. No measurement possible.	Defective, replace electronic unit.
F sensor electronic	Error, operational fault in the flow tube electronics. Parameter or hardware error. No measurement possible.	Defective, replace electronic unit.
F sensor global	Data error in the global data of the flow tube electronic equipment.	Load settings (C5.6.3) (backup 1, backup 2 or factory settings). If status message still does not disappear, replace electronic unit.
F sensor local	Data error in the local data of the flow tube electronic equipment.	Defective, replace electronic unit.
F field current local	Data error in the local data of the field current supply.	Defective, replace electronic unit.
F current output A	Error, operational fault in current output. Parameter or hardware error. No measurement possible.	Defective, replace electronic unit.
F current output C		
F software user interface	Fault revealed by CRC check of operation software.	Replace electronic unit.
F hardware settings	The set hardware parameters do not match the identified hardware. A dialogue appears in the display.	Answer queries in dialogue mode, follow directions. Defective, replace electronic unit.
F hardware detection	Existing hardware cannot be identified.	Defective, replace electronic unit.
F RAM/ROM error IO1	A RAM or ROM error is detected during the CRC check.	Defective, replace electronic unit.

Table 6-15: Operational faults in device

Messages on the display	Description	Actions
Status: F _ _ _ _ _	Application-dependent fault, device OK, but measured values affected.	Application test or operator action necessary.
F application error	Application-dependent fault, but device is okay.	Group message, when errors as described below or other application errors occur.
F empty pipe	1 or 2 measuring electrodes are not in contact with the medium; measured value is set to zero. No measurement possible.	Measuring pipe not filled, function dependent on C1.3.2. Check installation. Or electrodes completely insulated e.g. by oil film. Clean!
F flow exceeding limit	Measuring range exceeded, filter setting limits measured values. No message if empty pipe. If this limit occurs sporadically in processes with air pockets, solid contents or low conductivity, then either the limit has to be increased or a pulse filter used so as to quell the error messages and also reduce the measurement errors.	Limitation C1.2.1, increase values.
F field frequency too high	Field frequency is not reaching steady state, a measured flow value is still being supplied but may have errors. Measured values are still supplied, but they are always too low. No message if coil broken or bridged.	If "C1.1.14 settling time" is on "manual", increase the value in C1.1.15. If "standard" is set, set the field frequency in C1.1.13 according to the transmitter nameplate.
F DC offset	ADC over-ranged by DC offsets. No measurement can be performed, the flow is set to zero. No message if empty pipe.	For remote transmitters, check the connection of the signal cable.
F open circuit A	Load on current output A too high, effective current too low.	Current not correct, mA output cable has open circuit or load too high. Check cable, reduce load (set < 750 Ω).
F open circuit C		
F over range A	The current or the corresponding measured value is limited by a filter setting.	Check with "C2.1 hardware" or the sticker in the terminal compartment, which output is connected to the terminal. If current output: extend "C2.x.6 range" and "C2.x.8 limitation". If frequency output: extend values in "C2.x.5" and "C2.x.7".
F over range C		
F over range D	The pulse rate or the corresponding measured value is limited by a filter setting. Or the demanded pulse rate is too high.	
F active settings	Error during the CRC check of the active settings.	Upload backup 1 or backup 2 settings, check and adjust if necessary.
F factory settings	Error during the CRC check of the factory settings.	-
F backup 1 settings	Error during the CRC check of the backup 1 or 2 settings.	Save active settings in backup 1 or 2.
F backup 2 settings		

Table 6-16: Application error

Messages on the display	Description	Actions
Status: S _ _ _ _ _	Out of specification, measurement continues, accuracy possibly less.	Maintenance required.
S uncertain measurement	Device maintenance necessary; measured values only conditionally usable.	Group message, when errors as described below or other influences occur.
S empty pipe	1 or 2 measuring electrodes are not in contact with the medium; measured value is set to zero. No measurement possible.	Measuring pipe not filled, function dependent on C1.3.2. Check installation. Or electrodes completely insulated e.g. by oil film. Clean!

Messages on the display	Description	Actions
Status: S _ _ _ _ _	Out of specification, measurement continues, accuracy possibly less.	Maintenance required.
S electrode noise	Noise on the electrodes too high. Measured values are still supplied. No message if empty pipe.	a) Electrodes extremely soiled; b) Conductivity too low: activate noise or pulse filter C1.2.4, C1.2.7; c) Gas bubbles, solids or chem. reactions in medium: activate noise or pulse filter C1.2.4, C1.2.7; d) Electrode corrosion (if message also appears when flow is zero): use flow tube with suitable electrode material.
S field coil broken	Field coil resistance too high.	Check field coil connections to the electronic module (for remote versions: field current cable) for open circuit / short circuit
S field coil bridged	Field coil resistance too low.	
S electronic temperature	Upper limit for the permissible electronic temperature has been exceeded.	Ambient temperature too high, direct solar radiation or, for C version, process temperature too high.
S coil temperature	Upper limit for the permissible coil temperature has been exceeded. No message if coil broken/bridged.	Process and ambient temperature too high.
S overflow counter 1	This is counter 1. Counter has overrun and started again at zero.	-
S overflow counter 2	This is counter 2. Counter has overrun and started again at zero.	-
S backplane invalid	The data record on the backplane is invalid. The CRC check has revealed a fault.	No data can be loaded from the backplane when replacing electronics. Save the data to the backplane again (Service).
S field frequency too high	The field frequency is set so high that the field current cannot settle. The measured values displayed are too low.	Set field frequency lower; refer to C1.1.13.

Table 6-17: Measurements out of specification

Messages on the display	Description	Actions
Status: C _ _ _ _ _	Output values partially simulated or fixed	Maintenance required.
C checks in progress	Test mode of the device. Measured values are possibly simulated values or values with fixed settings.	Message depending on the situation via HART® or FDT.
C test sensor	Test function of the flow tube electronics is active.	-

Table 6-18: Simulation of the measured values

Messages on the display	Description	Actions
Status: I _ _ _ _ _	Information (current measurement OK)	If counter to continue counting, activate "yes" in "C2.y.9 start counter".
I counter 1 stopped	This is counter 1. The counter has stopped.	
I counter 2 stopped	This is counter 2. The counter has stopped.	

Messages on the display	Description	Actions
Status: I _ _ _ _ _	Information (current measurement OK)	
I power fail	The device was not in operation for an unknown period of time, because the power was switched off. This message is for information only.	Temporary power failure. Counters did not run during it.
I over range display 1	1st line on page 1 (2) of display limited by filter setting.	Menu display C4.3 and/or C4.4, select 1st or 2nd meas. page and increase values in "C4.z.3 range" and/or "C4.z.4 limitation".
I over range display 2		
I over range conductivity	The limits for the conductivity measurement have been exceeded (>10000 $\mu\text{S}/\text{cm}$) or are lower than permitted (<0.1 $\mu\text{S}/\text{cm}$).	If the flow tube has been properly connected and filled with medium, this does not affect the flow measurement. The conductivity measured values cannot be used.
I control input C act.	This message appears when the control input is active.	-
I backplane sensor	The data on the backplane are not usable because they have been generated with an incompatible version.	-
I backplane settings	The global settings on the backplane are not usable because they have been generated with an incompatible version.	-
I backplane difference	The data on the backplane differ from the data in the display. If the data are usable, a dialogue is indicated in the display.	-
I write cycles overfl.	The maximum number of write cycles of the EEPROM has been exceeded.	-
I conductivity off	Conductivity measurement switched off.	Changing of settings in C1.3.1.
I empty pipe	1 or 2 measuring electrodes are not in contact with the medium; measured value is set to zero. No measurement possible.	Measuring pipe not filled, function dependent on C1.3.2. Check installation. Or electrodes completely insulated e.g. by oil film. Clean!
I diagnosis channel off	Diagnosis value switched off.	Changing of settings in C1.3.17.

Table 6-19: Information

7.1 Spare parts availability

The manufacturer adheres to the basic principle that functionally adequate spare parts for each device or each important accessory part will be kept available for a period of 3 years after delivery of the last production run for the device.

This regulation only applies to spare parts which are subject to wear and tear under normal operating conditions.

7.2 Availability of services

The manufacturer offers a range of services to support the customer after expiration of the warranty. These include repair, maintenance, technical support and training.



NOTICE!

For more precise information, please contact your local sales office.

7.3 Returning the device to the manufacturer

7.3.1 General information

This device has been carefully manufactured and tested. If installed and operated in accordance with these operating instructions, it will rarely present any problems.



WARNING!

Should you nevertheless need to return a device for inspection or repair, please pay strict attention to the following points:

- *Due to statutory regulations on environmental protection and safeguarding the health and safety of the personnel, the manufacturer may only handle, test and repair returned devices that have been in contact with products without risk to personnel and environment.*
- *This means that the manufacturer can only service this device if it is accompanied by the following certificate (see next section) confirming that the device is safe to handle.*



WARNING!

If the device has been operated with toxic, caustic, radioactive, flammable or water-endangering products, you are kindly requested:

- *to check and ensure, if necessary by rinsing or neutralising, that all cavities are free from such dangerous substances,*
- *to enclose a certificate with the device confirming that it is safe to handle and stating the product used.*

7.3.2 Preapproval form - Customer returned process-wetted products

**LEGAL NOTICE!**

In compliance with U.S. Federal OSHA Standard 29CFR1910.1200 process information must be reviewed previous to receiving authorization to return material to Schneider Electric Systems USA, Inc.

NO PRODUCT EXPOSED TO HYDROFLUORIC ACID OR MERCURY WILL BE ACCEPTED!

Date: _____

Customer information

Customer's name:

Address:

Phone no:

Fax no.:

Contact's name:

Rep information

Rep's name:

Address:

Phone no:

Fax no.:

Contacts' name:

Product being returned:

Model No.:

Serial no.:

Under warranty?

YES

NO

Copies of MSDS sheets for all processes including cleaning solutions may be required.

Type of process (what chemicals/materials were processed through the unit):

Explain what steps were taken to decontaminate the unit: (was unit steam cleaned, rinsed out with water, chemically cleaned etc.)

Form completed by:

Print name

Signature

Date: _____

CLEANING STATEMENT

(Note: Your item will not be serviced unless the following cleaning statement has been signed):

I certify that the above referenced item has been properly purged and cleaned, complies with U.S. Department of Transportation shipping requirements and DOES NOT present a health and/or safety hazard (as defined by OSHA) to our Customer Repair personnel.

Print name: _____

Signature: _____

Print title: _____

Date: _____

Please fax the completed form to the Customer Satisfaction Center +1-508-549-4999

7.4 Disposal



LEGAL NOTICE!

Disposal must be carried out in accordance with legislation applicable in your country.

Separate collection of WEEE (Waste Electrical and Electronic Equipment) in the European Union:



According to the directive 2012/19/EU, the monitoring and control instruments marked with the WEEE symbol and reaching their end-of-life **must not be disposed of with other waste**. The user must dispose of the WEEE to a designated collection point for the recycling of WEEE or send them back to our local organisation or authorised representative.

8.1 Measuring principle

An electrically conductive fluid flows inside an electrically insulated pipe through a magnetic field. This magnetic field is generated by a current, flowing through a pair of field coils.

Inside of the fluid, a voltage U is generated:

$$U = v * k * B * D$$

in which:

v = mean flow velocity

k = factor correcting for geometry

B = magnetic field strength

D = inner diameter of flowmeter

The signal voltage U is picked off by electrodes and is proportional to the mean flow velocity v and thus the flow rate Q . A signal transmitter is used to amplify the signal voltage, filter it and convert it into signals for totalizing, recording and output processing.

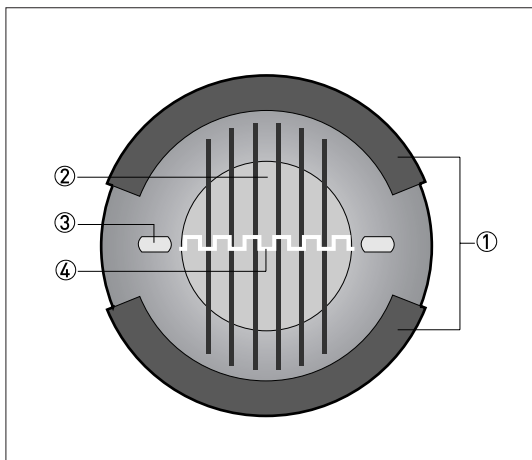

Figure 8-1: Measuring principle

- ① Field coils
- ② Magnetic field
- ③ Electrodes
- ④ Induced voltage (proportional to flow velocity)

8.2 Technical data



NOTICE!

- *The following data is provided for general applications. If you require data that is more relevant to your specific application, please contact us or your local sales office.*
- *Additional information (certificates, special tools, software,...) and complete product documentation can be downloaded free of charge from the website.*

Measuring system

Measuring principle	Faraday's law of induction
Application range	Continuous measurement of current volume flow, flow velocity, conductivity, mass flow (at constant density), coil temperature of the flow tube

Design

Modular construction	The measuring system consists of a flow tube and a transmitter.
Flow tube	
8400A	DN10...150 / 3/8...6"
8500A	DN2.5...100 / 1/10...4"
9500A	DN25...1200 / 1...48"
9600A	DN2.5...150 / 1/10...6"
9700A	DN2.5...1200 / 1/10...48"
	With the exception of the 8400A all flow tubes are also available in an Ex version.
Transmitter	
Compact (integral) version (C)	IMT31A-4 (0°) & IMT31A-6 (45°)
Wall-mounted remote version (W)	IMT31A-N
Options	
Outputs	Current output (including HART®), pulse output, frequency output, status output and/or limit switch
Counter	2 internal counters with a max. of 10 counter places (e.g. for counting volume and/or mass units)
Verification	Integrated verification, diagnostic functions: measuring device, empty pipe detection, stabilisation
Communication interfaces	HART® as standard

Display and user interface	
Graphic display	LC display, backlit white.
	Size: 128 x 64 pixels, corresponds to 59 x 31 mm = 2.32" x 1.22"
	Ambient temperatures below -25°C / -13°F may affect the readability of the display.
Operating elements	4 push buttons for operator control of the transmitter without opening the housing.
Remote control	PACTware™ (including Device Type Manager (DTM))
	HART® Communicator
	AMS®
	All DTMs and drivers are available free of charge from the manufacturer's website.
Display functions	
Operating menu	Setting the parameters using 2 measuring pages, 1 status page, 1 graphic page (measured values and graphics are freely adjustable)
Language display texts (as language package)	Standard: English, French, German, Dutch, Portuguese, Swedish, Spanish, Italian
	Eastern Europe: English, Slovenian, Czech, Hungarian
	Northern Europe: English, Danish, Polish, Finnish, Norwegian
	China: English, German, Chinese (check www.BuyAutomation.com for availability)
	Russia: English, German, Russian
Units	Metric, British and US units selectable as required from lists for volume / mass flow and counting, flow velocity, electrical conductivity, temperature

Measuring accuracy

Max. measuring accuracy	Standard: ±0.3% of the measured value ± 1 mm/s; depending on the flow tube
	Option (optimised accuracy with extended calibration): ±0.2% of the measured value ± 1.5 mm/s; depending on the flow tube
	For detailed information and accuracy curves refer to <i>Measuring accuracy</i> on page 103.
	Special calibrations are available on request.
	Current output electronics: ±10 µA; ±100 ppm/°C (typically: ±30 ppm/°C)
Repeatability	±0.1%

Operating conditions

Temperature	
Process temperature	Refer to technical data for the flow tube.
Ambient temperature	Depending on the version and combination of outputs.
	It is a good idea to protect the transmitter from external heat sources such as direct sunlight as higher temperatures reduce the life cycle of all electronic components.
	Ambient temperatures below -25°C / -13°F may affect the readability of the display.
Storage temperature	-40...+70°C / -40...+158°F
Pressure	
Medium	Refer to technical data for the flow tube.
Ambient pressure	Atmospheric
Chemical properties	
Electrical conductivity	All media except for water: $\geq 5 \mu\text{S}/\text{cm}$ (also refer to the technical data for the flow tube)
	Water: $\geq 20 \mu\text{S}/\text{cm}$
State of aggregation	Conductive, liquid media
Solid content (volume)	$\leq 10\%$
Gas content (volume)	$\leq 3\%$
Flow rate	For detailed information, refer to chapter "Flow tables".
Other conditions	
Ingress protection according to IEC 60529	Standard version with aluminium housing: IP66/67 (according to NEMA 4/4X)
	Optional version with stainless steel housing: IP69

Installation conditions

Installation	For detailed information, refer to chapter "Installation".
Inlet / outlet sections	Refer to technical data for the flow tube.
Dimensions and weight	For detailed information refer to chapter "Dimensions and weight".

Materials

Transmitter housing	Standard: Aluminum with a polyester topcoat
	Option: Stainless steel 1.4404 / AISI 316L
Flow tube	For housing materials, process connections, liners, grounding electrodes and gaskets, refer to technical data for the flow tube.

Electrical connection

General	Electrical connection is carried out in conformity with the VDE 0100 directive "Regulations for electrical power installations with line voltages up to 1000 V" or equivalent national specifications.
Power supply	100...230 VAC (-15% / +10%), 50/60 Hz; 240 VAC + 5% is included in the tolerance range.
	24 VDC (-55% / +30%); 12 VDC - 10% is included in the tolerance range.
	24 VAC/DC (AC: -15% / +10%; DC: -25% / +30%); 12 V is not included in the tolerance range.
Power consumption	AC: 7 VA
	DC: 4 W
Signal cable	Only necessary for remote versions.
	DS 300 (type A) Max. length: 600 m / 1968 ft (depending on electrical conductivity and flow tube version)
Cable entries	Standard: M20 x 1.5 (8...12 mm)
	Option: 1/2 NPT, PF 1/2

Inputs and outputs

General	All outputs are electrically isolated from each other and from all other circuits.
	All operating data and output values can be adjusted.
Description of abbreviations	U_{ext} = external voltage; R_L = load + resistance; U_0 = terminal voltage; I_{nom} = nominal current

Current output	
Output data	Volume flow, mass flow, diagnostic value, flow velocity, coil temperature, conductivity
Settings	Without HART®
	Q = 0%: 0...20 mA; Q = 100%: 10...21.5 mA
	Error identification: 20...22 mA
	With HART®
	Q = 0%: 4...20 mA; Q = 100%: 10...21.5 mA
	Error identification: 3...22 mA
Operating data	
Active	U _{int, nom} = 20 VDC
	I ≤ 22 mA R _L ≤ 750 Ω
	HART® at terminals A
Passive	U _{ext} ≤ 32 VDC
	I ≤ 22 mA U ₀ ≥ 2 V at I = 22 mA
	R _L ≤ (U _{ext} - U ₀) / I _{max}
	HART® at terminals A
HART®	
Description	HART® protocol via active and passive current output
	HART® version: V5
	Universal Common Practice HART® parameter: completely supported
Load	≥ 230 Ω at HART® test point; Note maximum load for current output!
Multi-drop mode	Yes, current output = 4 mA
	Multi-drop address adjustable in operation menu 1...15
Device drivers	Available for HART® Communicator, AMS®, FDT/DTM
Registration (HART Communication Foundation)	Yes

Pulse output / frequency output	
Output data	Pulse output: volume flow, mass flow
	Frequency output: volume flow, mass flow, diagnostic value, flow velocity, coil temperature, conductivity
Function	Can be set as a pulse output or frequency output
Pulse rate/frequency	0.25...10000 Hz
Settings	Pulses per volume or mass unit or max. frequency for 100% flow
	Pulse width: adjustable as automatic, symmetric or fixed (0.05...2000 ms)
Operating data	
Passive	$U_{\text{ext}} \leq 32 \text{ VDC}$ f_{max} in operating menu set to $f_{\text{max}} \leq 100 \text{ Hz}$: $I \leq 100 \text{ mA}$ open: $I \leq 0.05 \text{ mA}$ at $U_{\text{ext}} = 32 \text{ VDC}$ closed: $U_{0, \text{max}} = 0.2 \text{ V}$ at $I \leq 10 \text{ mA}$ $U_{0, \text{max}} = 2 \text{ V}$ at $I \leq 100 \text{ mA}$
	f_{max} in operating menu set to $100 \text{ Hz} < f_{\text{max}} \leq 10 \text{ kHz}$: $I \leq 20 \text{ mA}$ open: $I \leq 0.05 \text{ mA}$ at $U_{\text{ext}} = 32 \text{ VDC}$ closed: $U_{0, \text{max}} = 1.5 \text{ V}$ at $I \leq 1 \text{ mA}$ $U_{0, \text{max}} = 2.5 \text{ V}$ at $I \leq 10 \text{ mA}$ $U_{0, \text{max}} = 5.0 \text{ V}$ at $I \leq 20 \text{ mA}$
Low flow cut off	
Function	Switching point and hysteresis separately adjustable for each output, counter and the display
Switching point	Set in increments of 0.1%.
	0...20% (current output, frequency output) or 0...±9.999 m/s (pulse output)
Hysteresis	Set in increments of 0.1%.
	0...5% (current output, frequency output) or 0...5 m/s (pulse output)
Time constant	
Function	The time constant corresponds to the elapsed time until 67% of the end value has been reached according to a step function.
Settings	Set in increments of 0.1 seconds.
	0...100 seconds

Status output / limit switch	
Function and settings	Adjustable as automatic measuring range conversion, display of flow direction, counter overflow, error, switching point or empty pipe detection
	Valve control with activated dosing function
	Status and/or control: ON or OFF
Operating data	
Passive	$U_{ext} \leq 32 \text{ VDC}$ $I \leq 100 \text{ mA}$ open: $I \leq 0.05 \text{ mA}$ at $U_{ext} = 32 \text{ VDC}$ closed: $U_{0, max} = 0.2 \text{ V}$ at $I \leq 10 \text{ mA}$ $U_{0, max} = 2 \text{ V}$ at $I \leq 100 \text{ mA}$
Control input	
Function	Hold value of the outputs (e.g. for cleaning work), set value of the outputs to "zero", counter and error reset, range change.
	Start of dosing when dosing function is activated.
Operating data	
Passive	$U_{ext} \leq 32 \text{ VDC}$ $I_{nom} = 6.5 \text{ mA}$ at $U_{ext} = 24 \text{ VDC}$ $I_{nom} = 8.2 \text{ mA}$ at $U_{ext} = 32 \text{ VDC}$ Contact open (off): $U_0 \leq 2.5 \text{ V}$ at $I_{nom} = 0.4 \text{ mA}$ Contact closed (on): $U_0 \geq 8 \text{ V}$ at $I_{nom} = 2.8 \text{ mA}$

Approvals and certificates

CE	This device fulfils the statutory requirements of the relevant EU directives. The manufacturer certifies successful testing of the product by applying the CE mark. For full information of the EU directives & standards and the approved certifications, please refer to the EU declaration or the manufacturer website.
Non-Ex	Standard
Hazardous areas	
ATEX	Option (only 9500A & 9700A)
	II 2 G Ex e [ia] mb IIC T4 (DN10...20; DN200...300; DN350...3000)
	II 2 G Ex d e [ia] mb IIC T4 (DN25...150)
	II 2 G Ex e [ia] mb q T4/T3 (DN25...150; DN200...300)
	II 2 D Ex tD A21 IP64 T120°C (all nominal sizes)
	Option (Wall-mounted version only)
	II 2 G Ex e [ia] mb IIC T4
II 2 D Ex tD A21 IP64 T135°C	

IECEX	Option (only 9500A & 9700A)
	Ex e [ia] mb IIC T4 (DN10...20; DN200...300; DN350...3000)
	Ex d e [ia] mb IIC T4 (DN25...150)
	Ex tD A21 IP64 T120°C (all nominal sizes)
	Option (Wall-mounted version only)
	Ex e [ia] mb IIC T4
	Ex tD A21 IP64 T135°C
FM/CSA	Option (only 9500A & 9700A)
	Class I, Div 2, Group A, B, C and D
	Option (Wall-mounted version only)
	Class I, Div 2, Group A, B, C and D
	Ordinary location
Other standards and approvals	
Electromagnetic compatibility (EMC)	2004/108/EU in conjunction with EN 61326-1 (A1, A2)
Shock and vibration resistance	IEC 68-2-27, IEC 68-2-64
NAMUR	NE 21, NE 43, NE 53

8.3 Dimensions and weight

8.3.1 Housing

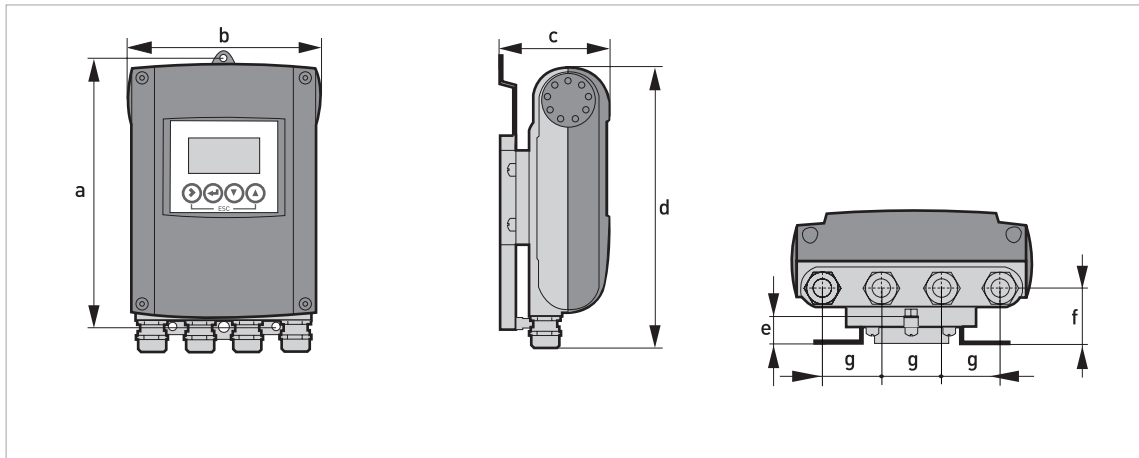

Figure 8-2: Dimensions of the wall-mounted version, aluminium housing

	Dimensions [mm]							Weight [kg]
	a	b	c	d	e	f	g	
Wall-mounted version	241	161	95.2	257	19.3	39.7	40	1.9

Table 8-1: Dimensions and weight in mm and kg

	Dimensions [inch]							Weight [lb]
	a	b	c	d	e	f	g	
Wall-mounted version	9.50	6.34	3.75	10.12	0.76	1.56	1.57	4.2

Table 8-2: Dimensions and weight in inch and lb

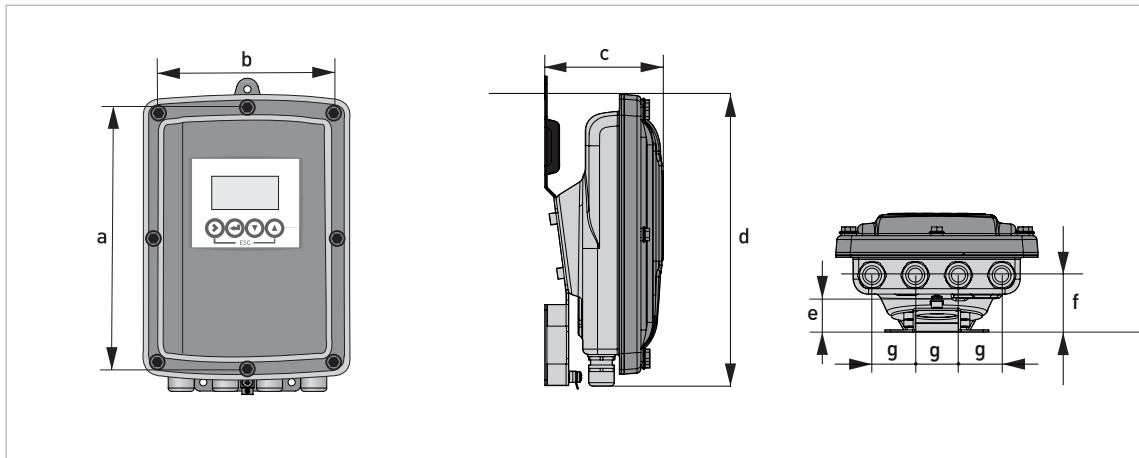

Figure 8-3: Dimensions of wall-mounted and compact 10° version, stainless steel housing

	Dimensions [mm]							Weight [kg]
	a	b	c	d	e	f	g	
Wall-mounted version	268	187	110	276	29	53	40	Approx. 3.5

Table 8-3: Dimensions and weight in mm and kg

	Dimensions [inch]							Weight [lb]
	a	b	c	d	e	f	g	
Wall-mounted version	10.55	7.36	4.33	10.87	1.14	2.09	1.57	Approx. 7.2

Table 8-4: Dimensions and weight in inch and lb



NOTICE!
The compact 10° version is without mounting plate.

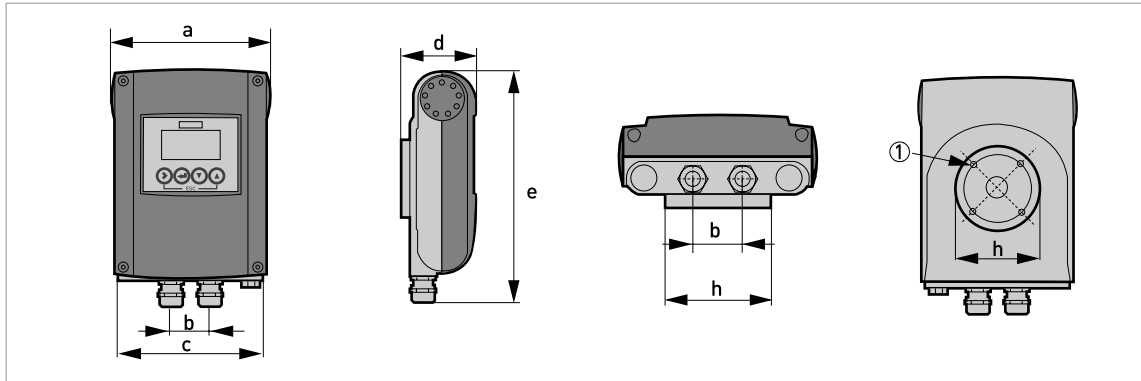

Figure 8-4: Dimensions of compact 0° version, aluminium housing

① 4 x M 6

	Dimensions [mm]								Weight [kg]
	a	b	c	d	e	f	g	h	
0° version	161	40	155	81.5	257	-	-	Ø72	Std: 1.9 Ex: 2.4

Table 8-5: Dimensions and weight in mm and kg

	Dimensions [inch]								Weight [lb]
	a	b	c	d	e	f	g	h	
0° version	6.34	1.57	6.1	3.21	10.12	-	-	Ø2.83	Std: 4.2 Ex: 5.3

Table 8-6: Dimensions and weight in inch and lb

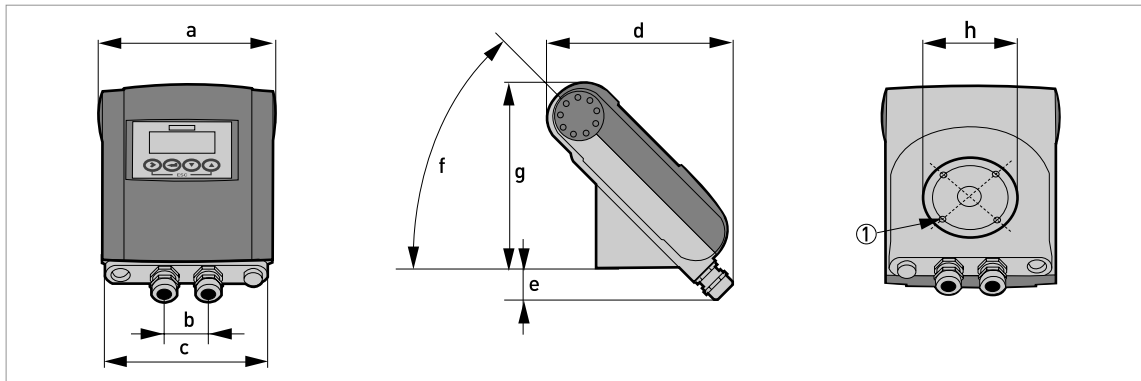

Figure 8-5: Dimensions of compact 45° version, aluminium housing

① 4 x M 6

	Dimensions [mm]								Weight [kg]
	a	b	c	d	e	f	g	h	
45° version	161	40	155	184	27.4	45°	186	Ø72	Std: 2.1 Ex: 2.6

Table 8-7: Dimensions and weight in mm and kg

	Dimensions [inch]								Weight [lb]
	a	b	c	d	e	f	g	h	
45° version	6.34	1.57	6.10	7.24	1.08	45°	7.32	Ø2.83	Std: 4.6 Ex: 5.7

Table 8-8: Dimensions and weight in inch and lb

8.3.2 Mounting plate of wall-mounted version, aluminium housing

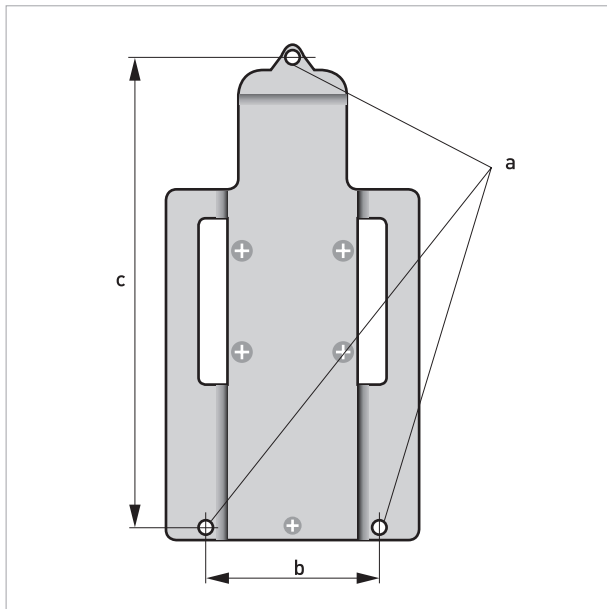

Figure 8-6: Dimensions of mounting plate of wall-mounted version, aluminium housing

	[mm]	[inch]
a	Ø6.5	Ø0.26
b	87.2	3.4
c	241	9.5

Table 8-9: Dimensions in mm and inch

8.3.3 Mounting plate of wall-mounted version, stainless steel housing

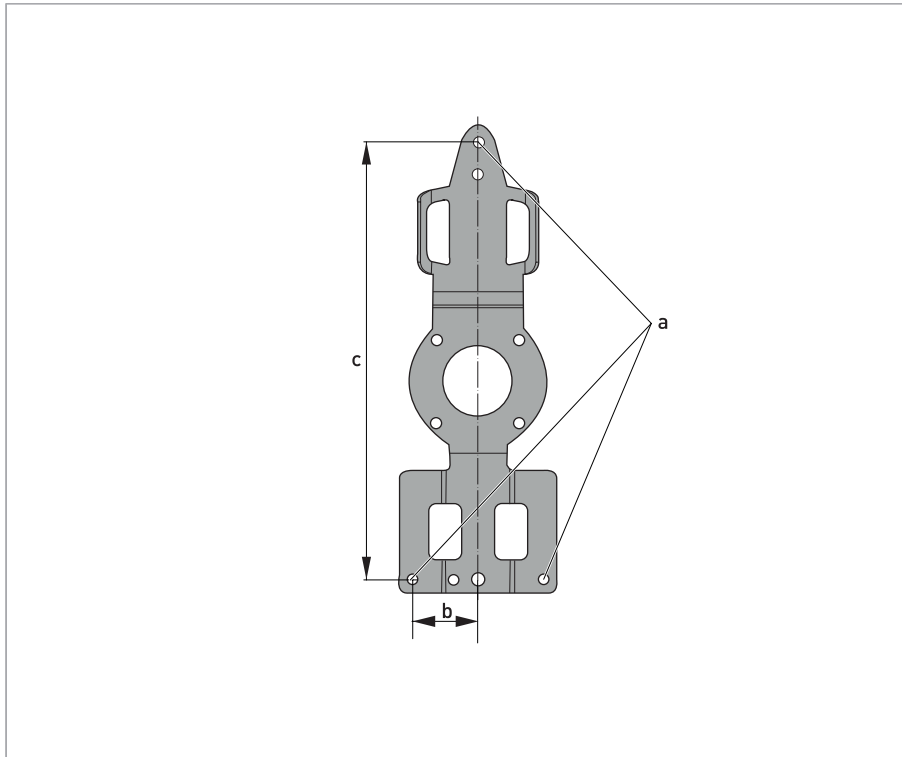

Figure 8-7: Dimensions of mounting plate of wall-mounted version, stainless steel housing

	[mm]	[inch]
a	Ø6.5	Ø0.26
b	40	1.6
c	267.9	10.55

Table 8-10: Dimensions in mm and inch

8.4 Flow tables

v [m/s]	Q _{100 %} in m ³ /h			
	0.3	1	3	12
DN [mm]	Minimum flow	Nominal flow		Maximum flow
2.5	0.005	0.02	0.05	0.21
4	0.01	0.05	0.14	0.54
6	0.03	0.10	0.31	1.22
10	0.08	0.28	0.85	3.39
15	0.19	0.64	1.91	7.63
20	0.34	1.13	3.39	13.57
25	0.53	1.77	5.30	21.21
32	0.87	2.90	8.69	34.74
40	1.36	4.52	13.57	54.29
50	2.12	7.07	21.21	84.82
65	3.58	11.95	35.84	143.35
80	5.43	18.10	54.29	217.15
100	8.48	28.27	84.82	339.29
125	13.25	44.18	132.54	530.15
150	19.09	63.62	190.85	763.40
200	33.93	113.10	339.30	1357.20
250	53.01	176.71	530.13	2120.52
300	76.34	254.47	763.41	3053.64
350	103.91	346.36	1039.08	4156.32
400	135.72	452.39	1357.17	5428.68
450	171.77	572.51	1717.65	6870.60
500	212.06	706.86	2120.58	8482.32
600	305.37	1017.90	3053.70	12214.80
700	415.62	1385.40	4156.20	16624.80
800	542.88	1809.60	5428.80	21715.20
900	687.06	2290.20	6870.60	27482.40
1000	848.22	2827.40	8482.20	33928.80
1200	1221.45	3421.20	12214.50	48858.00

Table 8-11: Flow rate in m/s and m³/h

	Q ₁₀₀ % in US gallons/min			
v [ft/s]	1	3.3	10	40
DN [inch]	Minimum flow	Nominal flow		Maximum flow
1/10	0.02	0.09	0.23	0.93
1/6	0.06	0.22	0.60	2.39
1/4	0.13	0.44	1.34	5.38
3/8	0.37	1.23	3.73	14.94
1/2	0.84	2.82	8.40	33.61
3/4	1.49	4.98	14.94	59.76
1	2.33	7.79	23.34	93.36
1.25	3.82	12.77	38.24	152.97
1.5	5.98	19.90	59.75	239.02
2	9.34	31.13	93.37	373.47
2.5	15.78	52.61	159.79	631.16
3	23.90	79.69	239.02	956.09
4	37.35	124.47	373.46	1493.84
5	58.35	194.48	583.24	2334.17
6	84.03	279.97	840.29	3361.17
8	149.39	497.92	1493.29	5975.57
10	233.41	777.96	2334.09	9336.37
12	336.12	1120.29	3361.19	13444.77
14	457.59	1525.15	4574.93	18299.73
16	597.54	1991.60	5975.44	23901.76
18	756.26	2520.61	7562.58	30250.34
20	933.86	3112.56	9336.63	37346.53
24	1344.50	4481.22	13445.04	53780.15
28	1829.92	6099.12	18299.20	73196.79
32	2390.23	7966.64	23902.29	95609.15
36	3025.03	10082.42	30250.34	121001.37
40	3734.50	12447.09	37346.00	149384.01
48	5377.88	17924.47	53778.83	215115.30

Table 8-12: Flow rate in ft/s and US gallons/min

8.5 Measuring accuracy

Every electromagnetic flowmeter is calibrated by direct volume comparison. The wet calibration validates the performance of the flowmeter under reference conditions against accuracy limits.

The accuracy limits of electromagnetic flowmeters are typically the result of the combined effect of linearity, zero point stability and calibration uncertainty.

Reference conditions

- Medium: water
- Temperature: +5...+35°C / +41...+95°F
- Operating pressure: 0.1...5 barg / 1.5...72.5 psig
- Inlet section: ≥ 5 DN; outlet section: ≥ 2 DN

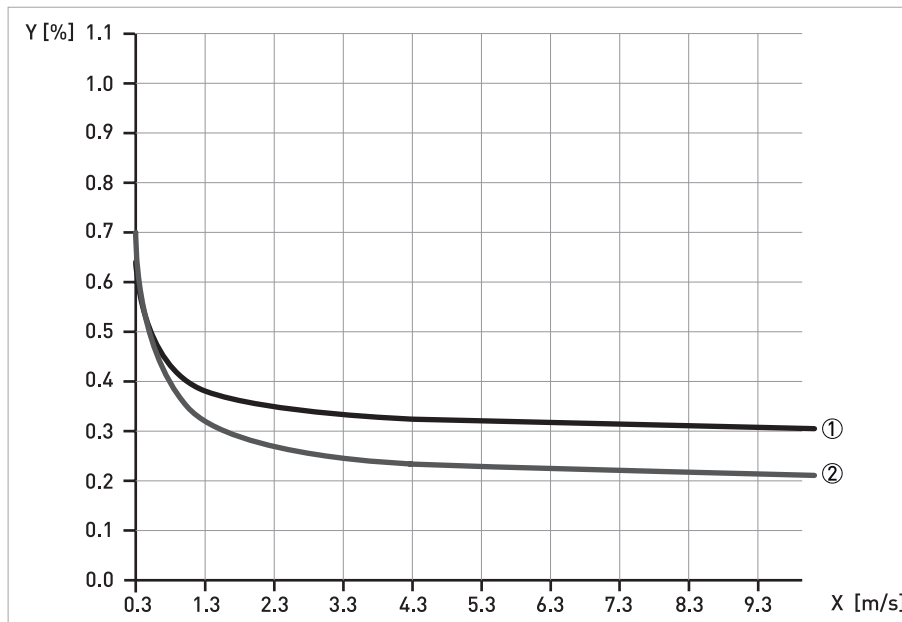

Figure 8-8: Measuring accuracy

X [m/s]: flow velocity

Y [%]: deviation from the actual measured value (mv)

	DN [mm]	DN [inch]	Standard accuracy ①	Optimised accuracy ②
8400A	10...150	3/8...6	±0.4% of mv ± 1 mm/s; as ① + 0.1%	-
8500A / 9600A / 9700A	2.5...6	1/10...1/4		
8500A / 9500A / 9600A / 9700A	10...1200	3/8...48	±0.3% of mv ± 1 mm/s	only 9500A / 9700A: ±0.2% of mv ± 1.5 mm/s Extended calibration at 2 points

Table 8-13: Measuring accuracy

9.1 General description

The open HART[®] protocol, which can be used freely, is integrated into the transmitter for communication.

Devices which support the HART[®] protocol are classified as either operating devices or field devices. When it comes to operating devices (Master), both manual control units (Secondary Master) and PC-supported workstations (Primary Master) are used in, for example, a control centre.

HART[®] field devices include flow tubes, transmitters and actuators. The field devices range from 2-wire to 4-wire to intrinsically safe versions for use in hazardous areas.

The HART[®] data are superimposed over the analogue 4...20 mA signal via FSK modem. This way, all of the connected devices can communicate digitally with one another via the HART[®] protocol while simultaneously transmitting the analogue signals.

When it comes to the field devices and secondary masters, the FSK or HART[®] modem is integrated, whereas with a PC communication takes place via an external modem which must be connected to the serial interface. There are, however, other connection variants which can be seen in the following connection diagrams.

9.2 Software history



NOTICE!

In the table below, "x" is a placeholder for possible multi-digit alphanumeric combinations, depending on the available version.

Release date	Electronic Revision	SW.REV.UIS	SW.REV.MS	HART [®]	
				Device Revision	DD Revision
2008-02-29	2.0.x	2.0.x	2.0.x	2	1
2010-01-04	2.1.x	2.1.x	3.0.x	3	1
2011-12-12	3.0.x	3.0.x	4.0.x	3	1
2014-08-01	3.1.x	3.1.x	4.0.x	4	1

Table 9-1: Software history

Manufacturer ID:	20 (0x14)
Device:	27 (0x1B)
HART® Universal Revision:	5
FC 375/475 system SW.Rev.:	≥ 1.8
AMS® version:	≥ 7.0
FDT version:	≥ 1.2

Table 9-2: HART® identification codes and revision numbers

9.3 Connection variants

The transmitter is a 4-wire device with 4...20 mA current output and HART® interface. Depending on the version, the settings and the wiring, the current output can operate as passive or active output.

- **Multi-drop mode is supported**
In a multi-drop communication system, more than 2 devices are connected to a common transmission cable.
- **Burst mode is not supported**
In the Burst mode a slave device transfers cyclic pre-defined response telegrams, to get a higher rate of data transfer.



NOTICE!

For detailed information about the electrical connection of the transmitter for HART®, refer to the section "Electrical connection".

There are two ways of using the HART® communication:

- as Point-to-Point connection and
- as multi-drop connection, with 2-wire connection or as multi-drop connection, with 3-wire connection.

9.3.1 Point-to-Point connection - analogue / digital mode

Point-to-Point connection between the transmitter and the HART[®] Master.

The current output of the device may be active or passive.

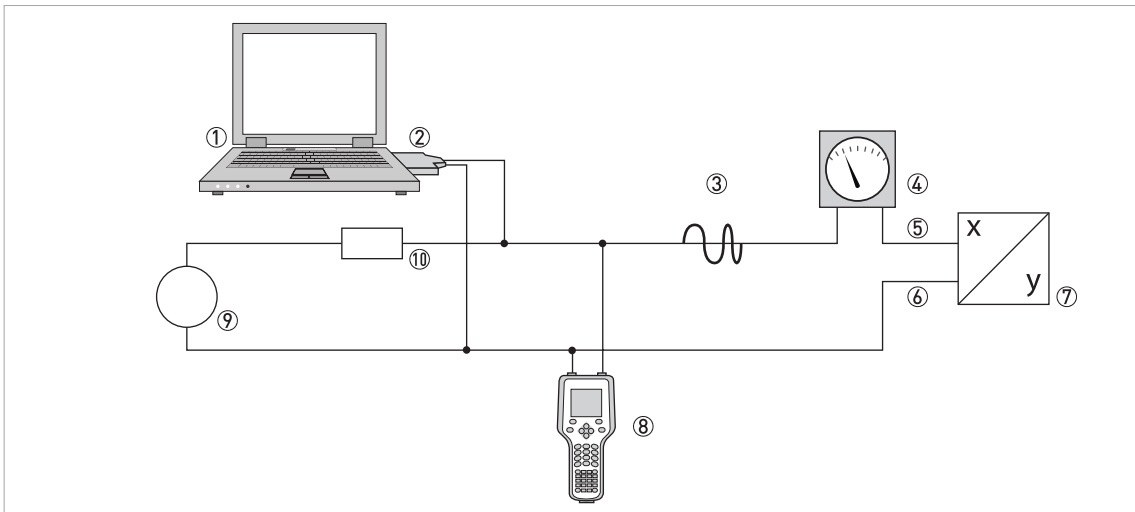

Figure 9-1: Point-to-Point connection

- ① Primary master
- ② FSK modem or HART[®] modem
- ③ HART[®] signal
- ④ Analog indication
- ⑤ Transmitter terminals A (C)
- ⑥ Transmitter terminals A- (C-)
- ⑦ Transmitter with address = 0 and passive or active current output
- ⑧ Secondary Master
- ⑨ Power supply for devices (slaves) with passive current output
- ⑩ Load $\geq 230 \Omega$

9.3.2 Multi-drop connection (2-wire connection)

In the case of a multi-drop connection, up to 15 devices may be installed in parallel (this transmitter and other HART[®] devices).

The current outputs of the devices must be passive!

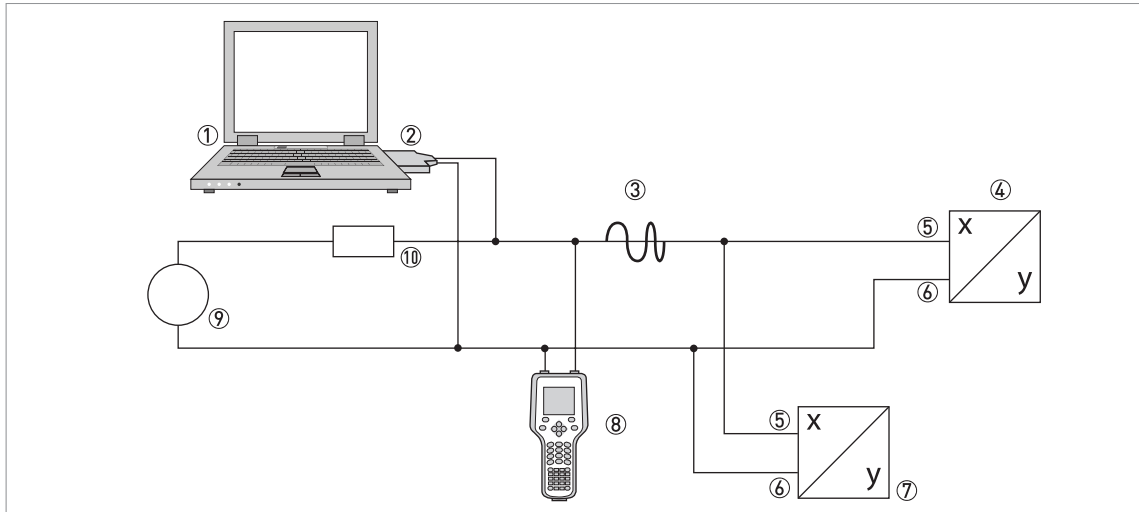

Figure 9-2: Multi-Drop connection (2-wire connection)

- ① Primary Master
- ② HART[®] modem
- ③ HART[®] signal
- ④ Other HART[®] devices or this transmitter (refer also to ⑦)
- ⑤ Transmitter terminals A (C)
- ⑥ Transmitter terminals A- (C-)
- ⑦ Transmitter with address ≥ 0 and passive current output, connection of max. 15 devices (slaves) with 4...20 mA
- ⑧ Secondary Master
- ⑨ Power supply
- ⑩ Load $\geq 230 \Omega$

9.3.3 Multi-drop connection (3-wire connection)

Connection of 2-wire and 4-wire devices in the same network. In order that the current output of the transmitter is working continuously active, an additional third wire must be connected to the devices in the same network. These devices must be powered via a 2-wire loop.

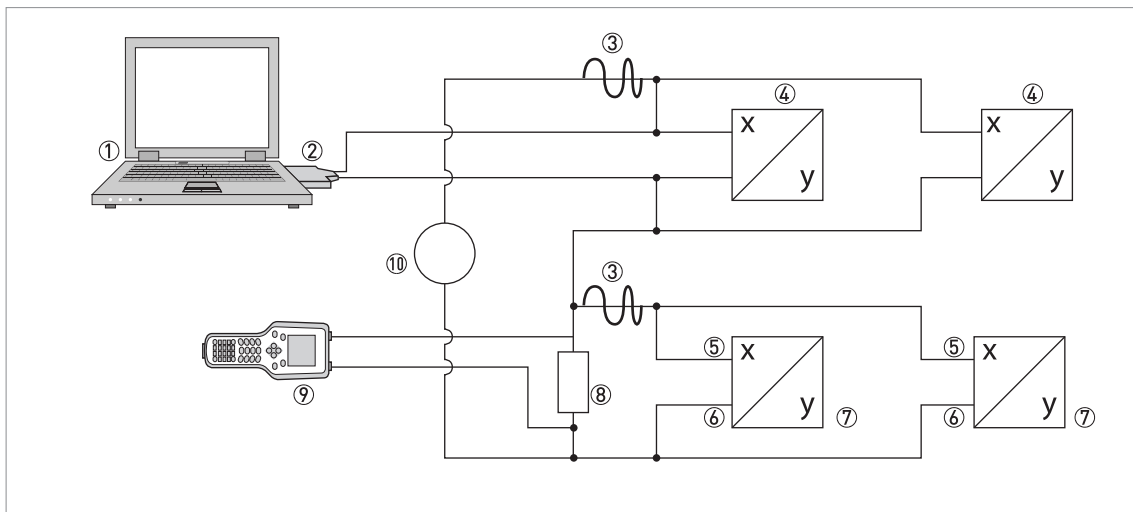

Figure 9-3: Multi-Drop connection (3-wire connection)

- ① Primary Master
- ② HART[®] modem
- ③ HART[®] signal
- ④ 2-wire external devices (slaves) with 4...20 mA, addresses > 0, powered by current loop
- ⑤ Transmitter terminals A (C)
- ⑥ Transmitter terminals A- (C-)
- ⑦ Connection of active or passive 4-wire devices (slaves) with 4...20 mA, addresses ≥ 0
- ⑧ Load ≥ 230 Ω
- ⑨ Secondary Master
- ⑩ Power supply

9.4 Inputs/outputs and HART dynamic variables and device variables

The transmitter is available with various input/output combinations.

The connection of the terminals A and D to the HART[®] dynamic variables PV, SV, TV and 4V depends on the device version.

PV = Primary Variable; SV = Secondary Variable; TV = Third Variable; 4V = Fourth Variable

Transmitter version	HART [®] dynamic variable			
	PV	SV	TV	4V
Basic I/O, connection terminals	A	D	-	-

Table 9-3: Connection of the terminals to the HART[®] dynamic variables

The transmitter can provide up to 8 measurement-related values. The measured values are accessible as so-called HART[®] device variables and can be connected to the HART[®] dynamic variables. The availability of these variables depends on the device versions and the settings.

Code = device variable code

HART [®] device variable	Code	Type	Explanations
flow speed	20	Linear	-
volume flow	21	Linear	
mass flow	22	Linear	
conductivity	24	Linear	
coil temperature	23	Linear	
counter 1	6	Counter	-
counter 2	14	Counter	
diagnosis value	25	Linear	Function and availability depends on diagnosis value setting.
operating hours	1	Counter	-

Table 9-4: Description of the HART[®] device variables

For the dynamic variables connected to the linear analogue outputs for current and/or frequency, the assignment of the device variables takes place by selecting the linear measurement for these outputs under the appropriate function of the transmitter. It follows that the dynamic variables connected to current or frequency outputs can only be assigned to the linear HART® device variables.

The HART® dynamic variable PV is always connected to the HART® current output which is, for example, assigned to the volume flow.

A totaliser device variable can thus not be assigned to the dynamic variable PV because the PV is always connected to the HART® current output.

Such correlations do not exist for dynamic variables not connected to linear analogue outputs. Both linear and totaliser device variables can be assigned.

The totaliser device variables can only be assigned to the dynamic variables SV, TV and 4V if the connected output is not a current or frequency output.

9.5 Parameter for the basic configuration

There are parameters, such as counter 1 or 2, and a selection of the diagnosis values, that require a warm start for the device following data changes in order to update dependent unit parameters, for example, before other parameters are written.

Depending on the characteristic of the HART® host system, e.g. online/offline mode, these parameters are treated differently. See the following section for more detailed information.

9.6 HART Communicator

The HART Communicator is a hand terminal that is designed to configure HART® devices. Device Descriptions (DDs) are used to integrate different devices into the HART Communicator.

9.6.1 Installation

The HART® Device Description for the transmitter must be installed on the HART Communicator. Otherwise only the functions of a generic DD are available to the user and the entire device control is not possible. A "Field Communicator Easy Upgrade Programming Utility" is required to install the DDs on the HART Communicator.

The HART Communicator must be equipped with a system card with "Easy Upgrade Option". For details consult the HART Communicator User's Manual.

9.6.2 Operation

**NOTICE!**

For more detailed information see Appendix A, Menu tree for Basic DD.

Operating the transmitter via the HART Communicator is very similar to manual device control using the keyboard.

Limitation: The service menu parameters for the device are not supported and a simulation is only possible for current outputs. The online help for each parameter contains its function number as a reference to the local device display.

Parameter protection for custody transfer is the same as on the device's local display. Other specific protective functions such as the passwords for the quick setup menu and the setup menu are not supported with HART®.

The HART Communicator always saves a complete configuration for the exchange with AMS®, see Appendix A. However, in the offline configuration and when sending to the device, the HART Communicator only takes into account a partial parameter set (like the standard configuration of the old HART Communicator 275).

9.6.3 Parameter for the basic configuration

In online mode, counter measurements and the diagnosis value can be set using special methods, see Appendix A. In offline mode, these parameters are read-only. However, when transferring the offline configuration, this data is also written to the device.

9.7 Asset Management Solutions (AMS)

The Asset Management Solutions Device Manager (AMS[®]) is a PC program which is designed to configure and manage HART[®] devices. Device Descriptions (DDs) are used to integrate different devices into the AMS[®].

9.7.1 Installation

If the transmitter Device Description has not yet been installed on the AMS[®] system, a so-called Installation Kit HART[®] AMS[®] is required. It is available for download from the website.

9.7.2 Operation

**NOTICE!**

For more detailed information see Appendix B, Menu tree for AMS[®].

Due to AMS[®] requirements and conventions, there are differences when operating the transmitter with AMS[®] and operating using the local keyboard. The service menu parameters are not supported and simulation is only possible for current outputs. The online help for each parameter contains its function number as a reference to the local device display.

Parameter protection for custody transfer is the same as on the device's local display. Other specific protective functions such as the passwords for the "quick setup" menu and the "setup" menu are not supported with HART[®].

9.7.3 Parameter for the basic configuration

In online mode, the measurements for counters and diagnosis values can be changed by using the appropriate methods in the basic configuration menu. These parameters are read-only in offline mode.

9.8 Field Device Tool / Device Type Manager (FDT / DTM)

A Field Device Tool (FDT) Container or Frame is basically a PC program used to configure HART® devices. To adapt to different devices, an FDT container/frame uses a so-called Device Type Manager (DTM).

9.8.1 Installation

If the Device Type Manager for the transmitter has not yet been installed on the Field Device Tool Container/Frame, setup is required and is available for download from the website. See the supplied documentation for information on how to install and set up the DTM.

9.8.2 Operation

Operating the transmitter via DTM is very similar to manual device control using the keyboard. See also local device display.

9.9 Appendix A: HART menu tree for Basic-DD

**NOTICE!**

The numbering in the following table may change depending on the version of the transmitter!

Abbreviations of the following tables:

- ^{Opt} Optional, depending on device version and configuration
- Rd Read only
- ^{Cust} Custody lock protection
- ^{Loc} Local, affects only DD host views

9.9.1 Overview Basic-DD menu tree (positions in menu tree)

1 dynamic var.	1 measurement	
	2 IO (Inputs/Outputs)	
2 quick setup	1 language	
	2 tag	
	3 reset	
	4 analogue outputs	
	5 digital outputs	
3 test	1 simulation	
	2 information	
4 setup	1 process input	1 calibration
		2 filter
		3 self test
		4 information
		5 sensor limits
	2 I/O	1 hardware
		2 terminals A
		3 terminals C
		4 terminals D
	3 I/O counter	1 counter 1
		2 counter 2
	4 I/O HART	1 PV is Rd
		2 SV is
		3 TV is
		4 4V is
		5 D/A trim
		6 apply values
		7 HART units
	5 device	1 device info
		2 display
		3 1. meas. page
		4 2. meas. page
		5 graphic page
		6 special functions
		7 units (device)
		8 HART

Table 9-5: Overview Basic-DD menu tree (positions in menu tree)

9.9.2 Basic-DD menu tree (details for settings)

1 dynamic var.

1 measurement	1 volume flow / 2 mass flow / 3 flow speed / 4 conductivity / 5 coil temperature / 6 counter 1 ^{Opt} / 7 counter 2 ^{Opt} / 8 diagnosis value ^{Opt}
2 I/O (Inputs/Outputs)	1 A ^{Opt} / 2 % range A ^{Opt} / 3 D ^{Opt} / 4 % range D ^{Opt}

2 quick setup

1 language	-
2 tag	-
3 reset	1 reset errors / 2 reset counter 1 ^{Cust} / 3 reset counter 2 ^{Cust}
4 analogue outputs	1 measurement A ^{Cust} / 2 unit ^{Cust} / 3 range min A ^{Cust} / 4 range max A ^{Cust} / 5 lfc threshold ^{Cust} / 6 lfc hysteresis ^{Cust} / 7 time constant ^{Cust}
5 digital outputs	1 measurement D ^{Opt, Cust} / 2 pulse value unit ^{Opt, Cust} / 3 value p. pulse D ^{Opt, Cust} / 4 lfc threshold ^{Opt, Cust} / 5 lfc hysteresis ^{Opt, Cust}

3 test

1 simulation	1 simul. current A ^{Opt} / 2 simul. frequency D ^{Opt}
2 information	1 C number / 2 info process input / 3 SW.REV.MS / 4 SW.REV.UIS

4 setup

1 process input	1 calibration	1 autom. zero calib. ^{Cust} / 2 zero calibration ^{Cust} / 3 size ^{Cust} / 4 GKL ^{Opt, Cust} / 5 coil resistance Rsp ^{Cust} / 6 density ^{Cust} / 7 target conduct. ^{Cust} / 8 EF electr. factor ^{Cust} / 9 field frequency ^{Cust} / 10 select settling ^{Cust} / 11 settling time ^{Opt Cust} / 12 line frequency ^{Cust}
	2 filter	1 limitation min ^{Cust} / 2 limitation max ^{Cust} / 3 flow direction ^{Cust} / 4 time constant / 5 pulse filter ^{Cust} / 6 pulse width ^{Opt, Cust} / 7 pulse limitation ^{Opt, Cust} / 8 noise filter ^{Cust} / 9 noise level ^{Opt, Cust} / 10 noise suppression ^{Opt, Cust} / 11 lfc threshold ^{Cust} / 12 lfc hysteresis ^{Cust}
	3 self test	1 empty pipe ^{Cust} / 2 limit empty pipe ^{Opt, Cust} / 3 electrode noise ^{Cust} / 4 limit electr. noise ^{Opt, Cust} / 5 settling of field ^{Cust} / 6 diagnosis value Rd / 7 select diagnosis

	4 information	1 liner / 2 electr. material / 3 serial no. sensor Rd / 4 V no. sensor Rd / 5 sensor electr. info					
	5 sensor limits	<table border="1"> <tr> <td>1 volume flow</td> <td rowspan="5">1 upper snsr limitRd / 2 lower snsr limitRd / 3 minimum spanRd</td> </tr> <tr> <td>2 mass flow</td> </tr> <tr> <td>3 flow speed</td> </tr> <tr> <td>4 conductivity</td> </tr> <tr> <td>5 coil temperature</td> </tr> </table>	1 volume flow	1 upper snsr limit Rd / 2 lower snsr limit Rd / 3 minimum span Rd	2 mass flow	3 flow speed	4 conductivity
1 volume flow	1 upper snsr limit Rd / 2 lower snsr limit Rd / 3 minimum span Rd						
2 mass flow							
3 flow speed							
4 conductivity							
5 coil temperature							
2 I/O	1 hardware	1 terminals A ^{Cust} / 2 terminals C ^{Cust} / 3 terminals D ^{Cust}					
	2 A 3 C 4 D	<p>current output Opt: 1 range 0%^{Cust} / 2 range 100%^{Cust} / 3 extended range min^{Cust} / 4 extended range max^{Cust} / 5 error current^{Cust} / 6 error condition^{Cust} / 7 measurement^{Cust} / 8 range min^{Cust} / 9 range max^{Cust} / 10 polarity^{Cust} / 11 limitation min^{Cust} / 12 limitation max^{Cust} / 13 lfc threshold^{Cust} / 14 lfc hysteresis^{Cust} / 15 time constant^{Cust} / 16 special function^{Cust} / 17 rc threshold^{Opt, Cust} / 18 rc hysteresis^{Opt, Cust} / 19 information</p> <p>frequency output Opt: 1 pulse shape^{Cust} / 2 pulse width^{Cust} / 3 100% pulse rate^{Cust} / 4 measurement^{Cust} / 5 range min^{Cust} / 6 range max^{Cust} / 7 polarity^{Cust} / 8 limitation min^{Cust} / 9 limitation max^{Cust} / 10 lfc threshold^{Cust} / 11 lfc hysteresis^{Cust} / 12 time constant^{Cust} / 13 invert signal^{Cust} / 14 special function^{Opt, Cust} / 15 information</p> <p>pulse output Opt: 1 pulse shape^{Cust} / 2 pulse width^{Cust} / 3 max. pulse rate^{Cust} / 4 measurement^{Cust} / 5 pulse value unit / 6 value p. pulse / 7 polarity^{Cust} / 8 lfc threshold^{Cust} / 9 lfc hysteresis^{Cust} / 10 time constant / 11 invert signal^{Cust} / 12 special function^{Opt, Cust} / 13 information</p> <p>status output Opt: 1 mode / 2 output A^{Opt} / 2 output C^{Opt} / 2 output D^{Opt} / 3 invert signal / 4 information</p> <p>limit switch Opt: 1 measurement / 2 threshold / 3 hysteresis / 4 polarity / 5 time constant / 6 invert signal / 7 information</p> <p>control input Opt: 1 mode^{Cust} / 2 invert signal / 3 information</p>					
	3 I/O counter	1 counter 1	1 funct. of counter ^{Cust} / 2 measurement ^{Cust, Rd} / 3 select measurement ^{Opt, Cust} / 4 lfc threshold ^{Opt, Cust} / 5 lfc hysteresis ^{Opt, Cust} / 6 time constant ^{Opt, Cust} / 7 preset value ^{Opt, Cust} / 8 reset counter ^{Opt, Cust} / 9 set counter ^{Opt, Cust} / 10 information				
		2 counter 2					
	4 I/O HART	1 PV is Rd / 2 SV is / 3 TV is / 4 4V is / 5 D/A trim ^{Cust} / 6 apply values ^{Cust} / 7 HART units					

5 device	1 device info	1 tag / 2 C number Rd / 3 device serial no. Rd / 4 electronic serial no. Rd / 5 SW.REV.MS / 6 circuit board info		
	2 display	1 language / 2 default display ^{Cust} / 3 SW.REV.UIS		
	3 1. meas. page 4 2. meas. page	1 function ^{Cust} / 2 measurement 1.line ^{Cust} / 3 range min ^{Cust} / 4 range max ^{Cust} / 5 limitation min / 6 limitation max / 7 lfc threshold / 8 lfc hysteresis / 9 time constant / 10 format 1.line / 11 measurement 2.line ^{Cust} / 12 format 2.line ^{Cust} / 13 measurement 3.line ^{Cust} / 14 format 3.line ^{Cust}		
	5 graphic page	1 select range / 2 range centre / 3 range +/- / 4 time scale		
	6 special functions	1 list errors / 2 reset errors / 3 warmstart		
	7 units (device)	1 volume flow ^{Cust} / 2 mass flow ^{Cust} / 3 flow speed ^{Cust} / 4 conductivity ^{Cust} / 5 temperature ^{Cust} / 6 volume ^{Cust} / 7 mass ^{Cust} / 8 density ^{Cust}		
	8 HART	1 address		
		2 message		
		3 description		
		4 units (HART)	1 volume flow	
		5 formats (HART)	2 mass flow	
			3 flow speed	
			4 conductivity	
			5 temperature	
			6 counter 1	
7 counter 2				
8 diagnosis value				
6 device info		1 manufacturer Rd		
		2 model Rd		
		3 device ID Rd		
	4 tag			
	5 date			
	6 write protect Rd			
	7 final assembly no.			
	8 sensor serial no.			
9 revision no.	1 universal rev. Rd			
	2 device rev. Rd			
	3 software rev. Rd			
	4 hardware rev. Rd			
7 preambles	1 request preams Rd			
	2 response preams			
8 master reset				
9 prepare download				

Table 9-6: Basic-DD menu tree (details for settings)

9.10 Appendix B: HART menu tree for AMS

Abbreviations of the following tables:

- ^{Opt} Optional, depending on device version and configuration
- Rd Read only
- ^{Cust} Custody lock protection
- ^{Loc} Local AMS®, affects only AMS® views

9.10.1 Overview AMS menu tree (positions in menu tree)

Configure	quick setup		
	sensor		
	input calibration		
	input filter		
	self test / info		
	I/O terminals A/C/D	current output	
		frequency output	
		pulse output	
		status output	
		limit switch	
	counter	counter 1	
		counter 2	
	device		
	1. meas. page / graphic page / 2. meas. page		
HART			
HART units			
Compare			
Clear Offline			
Status	Overview		
	Failure (device)		
	Failure (application)		
	Out of specification		
	Check request & Information		
Process Variables	process values		
	counter		
	outputs		
	device		
	HART		
Scan Device			
Calibration Management			

Diagnostics and Test
Calibrate
Reset
Basic Configuration
Rename
Unassign
Assign / Replace
Audit Trail
Record Manual Event
Drawings / Notes
Help...

Table 9-7: Overview AMS® menu tree (positions in menu tree)

9.10.2 AMS menu tree (details for settings)

Configure

quick setup	device	language / tag	
	current output A	measurement A ^{Cust} / unit A ^{Cust} / time constant A ^{Cust} / range max A ^{Cust} / range min A ^{Cust} / lfc threshold ^{Cust} / lfc hysteresis ^{Cust}	
	pulse output D	measurement D ^{Opt, Cust} / pulse value unit ^{Opt, Cust} / value p. pulse ^{Opt, Cust} / lfc threshold ^{Opt, Cust} / lfc hysteresis ^{Opt, Cust}	
sensor	limits for...	volume flow	upper snsr limit Rd / lower snsr limit Rd / minimum span Rd
		mass flow	
		flow speed	
		conductivity	
		coil temperature	
input calibration	zero calibration ^{Cust} / size ^{Cust} / GKL ^{Opt, Cust} / coil resistance Rsp ^{Cust} / density ^{Cust} / target conduct. ^{Cust} / EF electr. factor ^{Cust} / field frequency ^{Cust} / select settling ^{Cust} / settling time ^{Opt, Cust} / line frequency ^{Cust}		
input filter	limitation min ^{Cust} / limitation max ^{Cust} / flow direction ^{Cust} / time constant / pulse filter ^{Cust} / pulse width ^{Cust} / pulse limitation ^{Cust} / noise filter ^{Cust} / noise level ^{Cust} / noise suppression ^{Opt, Cust} / lfc threshold ^{Cust} / lfc hysteresis ^{Cust}		
self test / info	self test	empty pipe ^{Cust} / limit empty pipe ^{Opt, Cust} / electrode noise ^{Cust} / limit electr. noise ^{Opt, Cust} / settling of field ^{Cust} / diagnosis value Rd	
	information	liner / electr. material / serial no. sensor Rd / V no. sensor Rd /	

I/O terminals A/C/D	current output ^{Opt}	range 0% ^{Cust} / range 100% ^{Cust} / extended range min ^{Cust} / extended range max ^{Cust} / error current ^{Cust} / error condition ^{Cust} / measurement ^{Cust} / range min ^{Cust} / range max ^{Cust} / polarity ^{Cust} / limitation min ^{Cust} / limitation max ^{Cust} / lfc threshold ^{Cust} / lfc hysteresis ^{Cust} / time constant ^{Cust} / special function ^{Cust} / rc threshold ^{Opt, Cust} / rc hysteresis ^{Opt, Cust}
	frequency output ^{Opt}	pulse shape ^{Cust} / pulse width ^{Cust} / 100% pulse rate ^{Cust} / measurement ^{Cust} / range min ^{Cust} / range max ^{Cust} / polarity ^{Cust} / limitation min ^{Cust} / limitation max ^{Cust} / lfc threshold ^{Cust} / lfc hysteresis ^{Cust} / time constant / invert signal ^{Cust} / special function ^{Opt, Cust}
	pulse output ^{Opt}	pulse shape ^{Cust} / pulse width ^{Cust} / max. pulse rate ^{Cust} / measurement ^{Cust} / pulse value unit / value p. pulse / polarity ^{Cust} / lfc threshold ^{Cust} / lfc hysteresis ^{Cust} / time constant / invert signal ^{Cust} / special function ^{Opt, Cust}
	status output ^{Opt}	mode ^{Cust} / output A ^{Opt} / output C ^{Opt} / output D ^{Opt} / invert signal
	limit switch ^{Opt}	measurement ^{Cust} / threshold / hysteresis / polarity / time constant / invert signal
	control input ^{Opt}	mode ^{Cust} / invert signal
counter	counter 1	function ^{Cust} / measurement ^{Opt, Cust} /
	counter 2	lfc threshold ^{Opt, Cust} / lfc hysteresis ^{Opt, Cust} / time constant ^{Opt, Cust} / preset value ^{Opt, Cust}
device	device info	tag / C number Rd / device serial no. Rd / electronic serial no. Rd
	display	language / default display ^{Cust}
	units	volume flow ^{Cust} / mass flow ^{Cust} / flow speed ^{Cust} / conductivity ^{Cust} / temperature ^{Cust} / volume ^{Cust} / mass ^{Cust} / density ^{Cust}
1. and 2. meas. page graphic page	1. and 2. meas. page	function ^{Cust} / measurement 1.line ^{Cust} / range min ^{Cust} / range max ^{Cust} / limitation min / limitation max / lfc threshold / lfc hysteresis / time constant / format 1.line / measurement 2.line ^{Cust} / format 2.line ^{Cust} / measurement 3.line ^{Cust} / format 3.line ^{Cust}
	graphic page	select range / range centre / range +/- / time scale

HART	identification	manufacturer Rd / model Rd / device ID Rd / address / tag / date / message / description / write protect Rd / final assembly no. / serial no. sensor
	revision numbers	universal rev. Rd / device rev. Rd / software rev. Rd / hardware rev. Rd
	preambles	request preams Rd / response preams
	dynamic var.	PV is Rd / SV is / TV is / 4V is
HART units	display formats	volume flow ^{Loc} / mass flow ^{Loc} / flow speed ^{Loc} / conductivity ^{Loc} / temperature ^{Loc} / counter 1 ^{Loc} / counter 2 ^{Loc} / diagnosis value ^{Opt, Loc}
	units	volume flow / mass flow / flow speed / conductivity / temperature / counter 1 / counter 2 /

Compare and Clear Offline

Status

Overview	Standard	Primary variable out of limits
		Non-primary variable out of limits
		Primary variable analogue output saturated
		Primary variable analogue output fixed
		Cold start
		Field device malfunction
		Configuration changed
Failure (device)	F error in device / F IO 1 / F parameter / F configuration / F display / F sensor electronic / F sensor global / F sensor local / F field current local / F current output A / F software user interface / F hardware settings / F hardware detection / F RAM/ROM error IO1	
Failure (application)	F application error / F empty pipe / F flow rate too high / F field frequency too high / F DC offset / F open circuit A / F over range A (current) / F over range D (pulse) / F active settings / F factory settings / F backup 1 settings / F backup 2 settings	
Out of specification	S out of specification / S pipe not full / S empty pipe / S linearity / S flow profile / S electrode noise / S gain error / S electrode symmetry / S field coil broken / S field coil bridged / S field current deviation / S field frequency too high / S electronic temperature / S coil temperature / S overflow counter 1 / S overflow counter 2 / S Backplane Invalid	
Check request & Information	check request	C checks in progress / C test sensor
	information	I counter 1 stopped / I counter 2 stopped / I power fail / I over range display 1 / I over range display 2 / I backplane sensor / I backplane settings / I backplane difference / I optical interface

Process Variables

process values	volume flow / mass flow / flow speed / conductivity / coil temperature / diagnosis value Opt
counter	counter 1 ^{Opt} / counter 2 ^{Opt}
outputs	A ^{Opt} / % range A ^{Opt} / D ^{Opt} / % range D ^{Opt}
device	tag Rd / description Rd
HART	polling address Rd / device ID Rd

Scan Device

Calibration Management

Diagnostics and Test

	simulation A ^{Opt, Cust} / simulation D ^{Opt, Cust} / circuit board info
--	--

Calibrate

	autom. zero calibration ^{Cust} / D/A trim ^{Cust} / apply values ^{Cust}
--	---

Reset

	reset errors / reset configuration changed flag / master reset / warmstart / reset counter 1 ^{Cust} / set counter 1 ^{Cust} / reset counter 2 ^{Cust} / set counter 2 ^{Cust}
--	---

Basic Configuration

	select measurement counter 1 / select measurement counter 2 / select diagnosis value
--	--

Rename

Unassign

Assign / Replace

Audit Trail

Record Manual Event

Drawings / Notes

Help...

Table 9-8: AMS[®] menu tree (details for settings)



Schneider Electric Systems USA, Inc. Global Customer Support
38 Neponset Avenue Inside U.S.: 1-866-746-6477
Foxboro, MA 02035 Outside U.S.: 1-508-549-2424
United States of America <https://pasupport.schneider-electric.com>
<http://www.se.com>

Copyright 2020 Schneider Electric Systems USA, Inc.
All rights reserved.

The Schneider Electric brand and any trademarks of
Schneider Electric SE or its subsidiaries are the property
of Schneider Electric SE or its subsidiaries.
All other trademarks are the property of their respective
owners.

