

PC191 Pneumatic Selector Relays
PS953 Pneumatic Change over and Lock-In Relays



These Pneumatic Relays (Selection, Change Over and Lock-In) are designed for valve positioner hook up system and for safety (fail modus) definition. These Relays are a concentrate of several decade of experience in designing and producing “best in class” pneumatic instruments.

SELECTOR RELAYS

- Minimum selection
- Maximum selection

LOCK-IN RELAYS

- Single acting
- Double acting

CHANGE OVER RELAYS

- By exceeding set point
- By below set point
- Change Over from 0 to a given pressure
- Change Over between two given pressures
- With or without self-latch function

For all Relays

- EAC (CU TR) certified

*Equipment should be installed, operated, serviced, and maintained only by qualified personnel.
No responsibility is assumed by Schneider Electric for any consequences arising from the use of this material.*

PC191 Pneumatic Selector Relays

Version	Function diagram	Application	Model Code PC191
Min.-selector relay 2 inputs Input E1, E2		Selection of lowest input pressure	-101
Max.-selector relay 2 inputs Input E1, E2		Selection of highest input pressure and simultaneously increase in airflow rate	-102

PS953 Pneumatic Lock-In Relays

Version	Symbol	Function diagram	Application	Model Code
single acting			If the supply air pressure drops below the mechanically adjusted setpoint (safety limit), the output line to the final control element is sealed off.	-200
double acting			If the supply air pressure drops below the mechanically adjusted setpoint (safety limit), both output lines to the final control element is sealed off.	-210

PS953 Pneumatic Change-Over Relays

Version	Symbol	Function diagram	Application	Model Code
Signal selector relay mechanical set-point change-over if setpoint is exceeded			Signal pressure passes to output when mechanically adjusted setpoint is exceeded by pilot pressure	-100
Signal selector relay, mechanical setpoint, change-over if pilot pressure drops below set-point.			Signal pressure passes to output while pilot pressure remains below mechanically adjusted set-point	-101
Three-way signal selector relay, mechanical set-point, change-over if setpoint is exceeded, reversing if setpoint pilot pressure drops below setpoint			Change-over takes place when mechanically adjusted setpoint is exceeded, reversing when pilot pressure falls below set-point	-111
Three-way signal selector relay, mechanical set-point (0.2 to 1 bar), with self-latch, change-over if setpoint is exceeded, reversing manual	without electr. switch 		Changeover takes place when mechanically adjusted setpoint is exceeded. Reversing takes place on venting by a push-button valve Optional Feature -A	-112
Three-way signal selector relay for pressure difference, mechanical setpoint (0 - 1 bar) with self-latch, change-over if setpoint is exceeded, reversing manual			For single pressure difference. When pressure difference E2 - E1 exceeds the mechanically adjusted setpoint K, the output switched over from E4 to E3. Reversion takes place on venting by push-button valve optional feature -A.	-114
Change-over relay			Changeover of output results when pilot pressure E1 jumps from min. range 0 to 0.2 bar up to max. range 1 to 1.4 bar. The reverse effect takes place with a sharply dropping pressure change.	-613

Version	Application	Model Code
Push-button valve	for venting pneumatic signal lines	Option -A

**PC191-101 Minimum Pressure Selection
1 out of 2 inputs**

Min. pressure difference
between E1 and E2 ± 4 mbar
Weight 0.3 kg
Input Pressure 1 and 2 max 6 bar (90 psi)
Supply air max 6 bar (90 psi)
Air consumption 10 l/h
Air delivery 3 000 l/h
Air exhaust 1 800 l/h at $\Delta p = 1$ bar

**PC191-102 Maximum Pressure Selection
1 out of 2 inputs**

Min. pressure difference
between E1 and E2 ± 4 mbar
Weight 0.5 kg
Input Pressure 1 and 2 max 6 bar (90 psi)
Supply air max 6 bar (90 psi)
Air consumption 10 l/h
Air delivery 3 000 l/h
Air exhaust 1 800 l/h at $\Delta p = 1$ bar

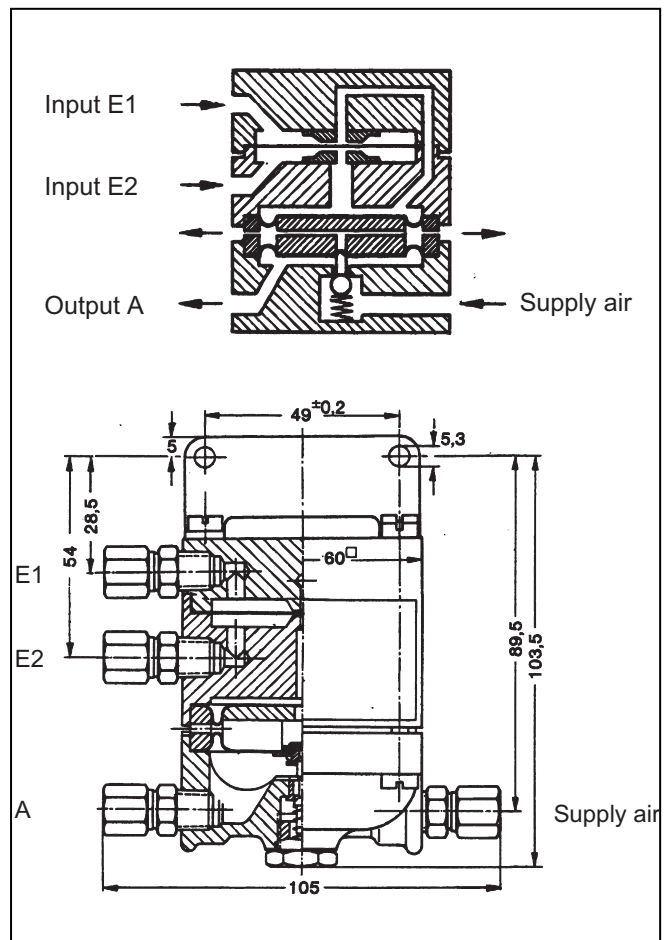
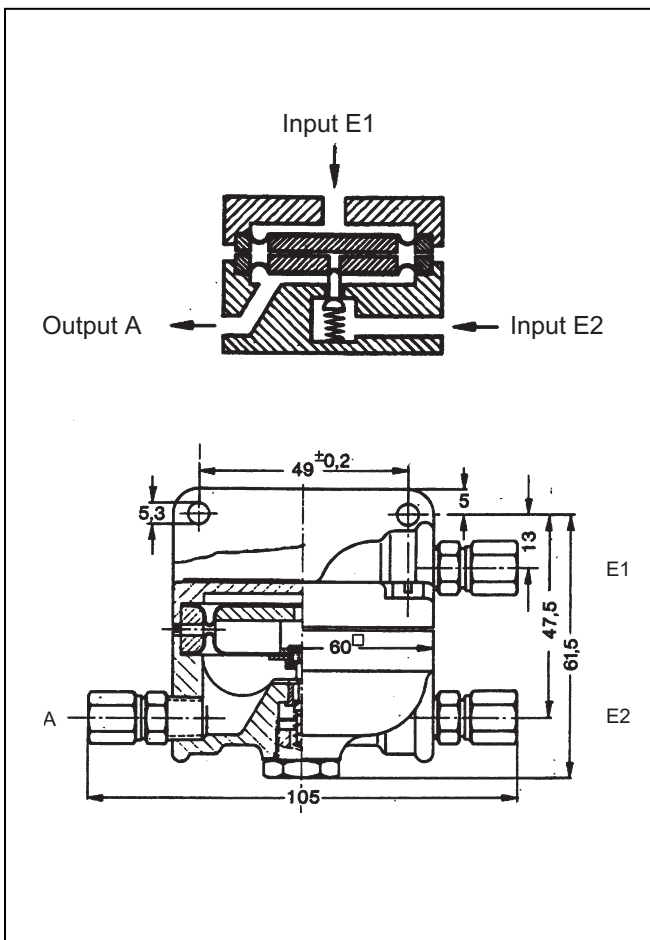

**PS953-100 Signal selector relay,
mechanical setpoint change-over if setpoint is exceeded**

**PS953-101 Signal selector relay,
mechanical setpoint change-over if setpoint drops
below setpoint**

Pilot pressure E1 0.2 to 1 bar / 3 to 15 psi /
20 to 100 kPa,
max. 6 bar / 90 psi / 600 kPa
Input E2. 0 to max. 10 bar /
0 to max. 150 psi /
0 to max. 1000 kPa
Output A according to switch position,
E2, or zero
Supply air 1.4 ± 0.1 bar / 20 ± 1.4 psi /
 140 ± 10 kPa, to max. 6 bar /
90 psi / 600 kPa

Setpoint adjustment K
equivalent to 0.2 to 1 bar / 3 to 15 psi /
20 to 100 kPa, max. 1.4 bar /
20 psi / 140 kPa
Switching hysteresis. < 2 % of final value
Temperature effect. ≤ 0.5 % / 10 K
Supply air dependency. ≤ 0.3 % / 0.1 bar
Air consumption. 0 / 100 l/h
Max. air throughput 1500 l/h at $\Delta p = 1$ bar
Weight 2 kg

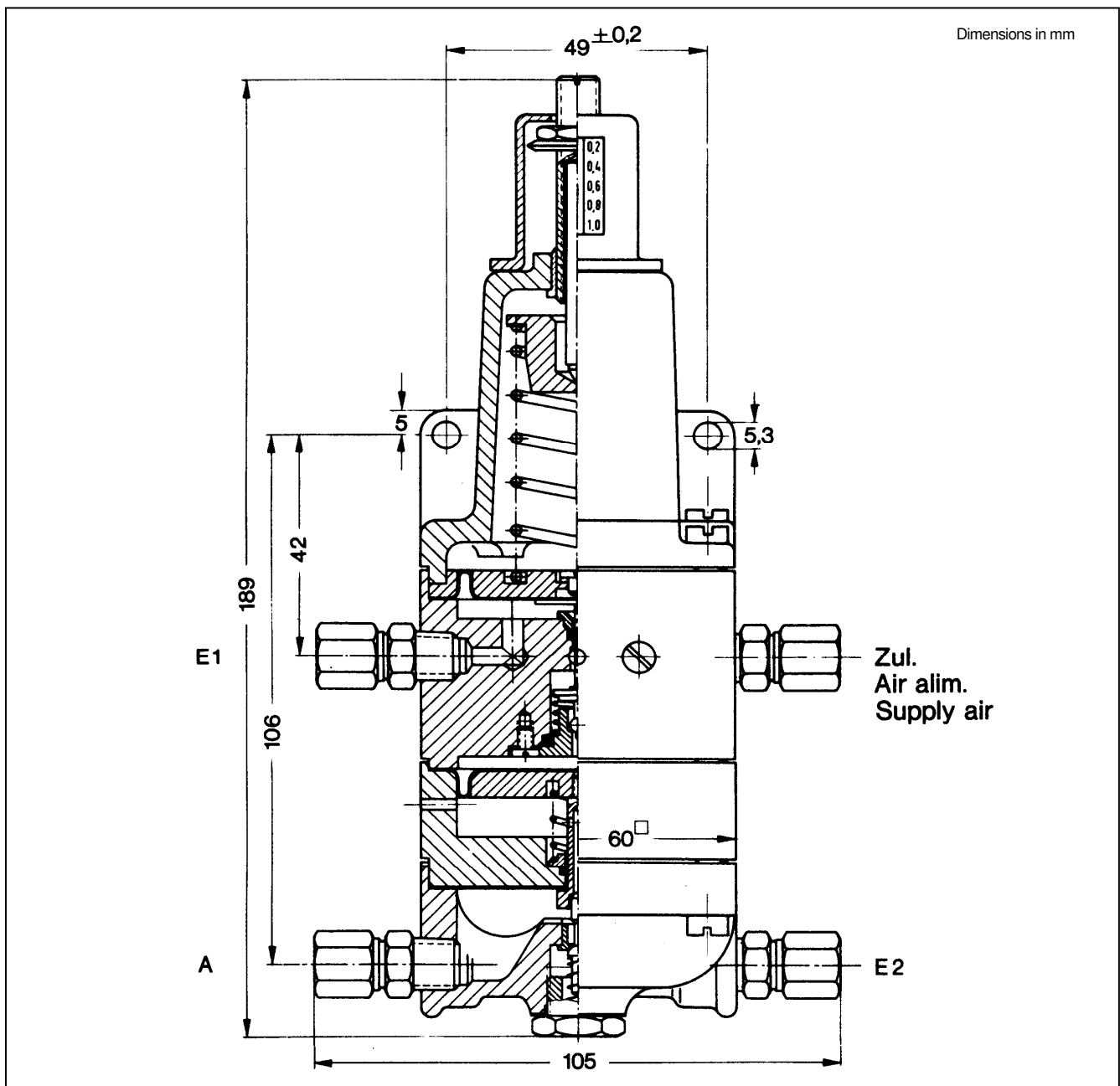

Dimensional drawing shows tube fittings 1/8-NPT for pipe 6 x 1. These are not supplied with the relays and must be ordered separately.

PS953-111 Three-way signal selector relay, mech. setpoint change-over if setpoint is exceeded, reversing if setpoint is drops

Pilot pressure E1 0.2 to 1 bar / 3 to 15 psi /
20 to 100 kPa,
max. 6 bar / 90 psi / 600 kPa
Input E2 ¹⁾, E3 ¹⁾ 0 to 6 bar / 0 to 90 psi /
0 to 600 kPa
Output A ¹⁾ according to switch position,
E2 or E3
Supply air 1.4 ± 0.1 bar / 20 ± 1.4 psi /
140 ± 10 kPa, to max. 6 bar /
90 psi / 600 kPa

Setpoint adjustment K
equivalent to 0.2 to 1 bar / 3 to 15 psi /
20 to 100 kPa,
max. 1.4 bar / 20 psi /
140 kPa
Switching hysteresis. 5 to 6 % due to snap-action
changeover
Temperature effect. ≤ 0.5 % / 10 K
Supply air dependency. ≤ 0.3 % / 0.1 bar
Air consumption. 0 / 200 l/h
Air delivery. 3 000 l/h at Δp = 1 bar
Air exhaust 3 000 l/h at Δp = 1 bar
Weight. 1 kg

1) Flow direction reversible

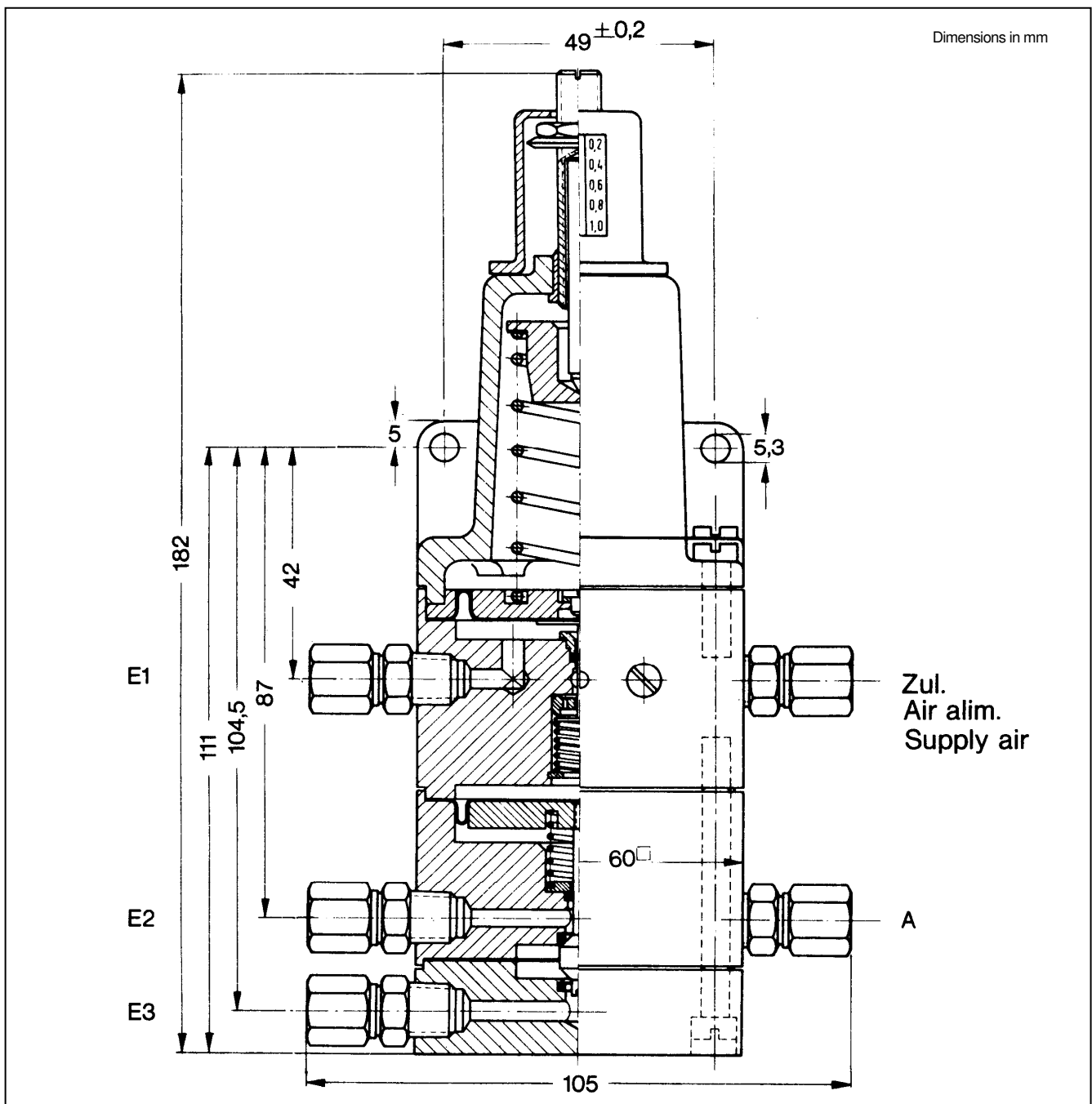

Dimensional drawing shows tube fittings 1/8-NPT for pipe 6 x 1. These are not supplied with the relays and must be ordered separately.

PS953-112 Three-way signal selector relay, mech.setpoint (0.2-1 bar) with self-latch, change-over if setpoint is exceeded, reversing manual

Pilot pressure E1 0.2 to 1 bar / 3 to 15 psi / 20 to 100 kPa, max. 6 bar / 90 psi / 600 kPa
 Input E2¹⁾, E3¹⁾ 0 to 6 bar / 0 to 90 psi / 0 to 600 kPa
 Output A¹⁾ according to switch position, E2 or E3
 Supply air 1.4 ± 0.1 bar / 20 ± 1.4 psi / 140 ± 10 kPa, to max. 6 bar / 90 psi / 600 kPa

Setpoint adjustment K equivalent to 0.2 to 1 bar / 3 to 15 psi / 20 to 100 kPa, max. 1.4 bar / 20 psi / 140 kPa
 Switching hysteresis 5 to 6 % due to snap action changeover
 Temperature effect ≤ 0.5 % / 10 K
 Supply air dependency ≤ 0.3 % / 0.1 bar
 Air consumption 0 / 200 l/h
 Air delivery 3 000 l/h at Δp = 1 bar
 Air exhaust 3 000 l/h at Δp = 1 bar
 Weight 1.1 kg

1) Flow direction reversible

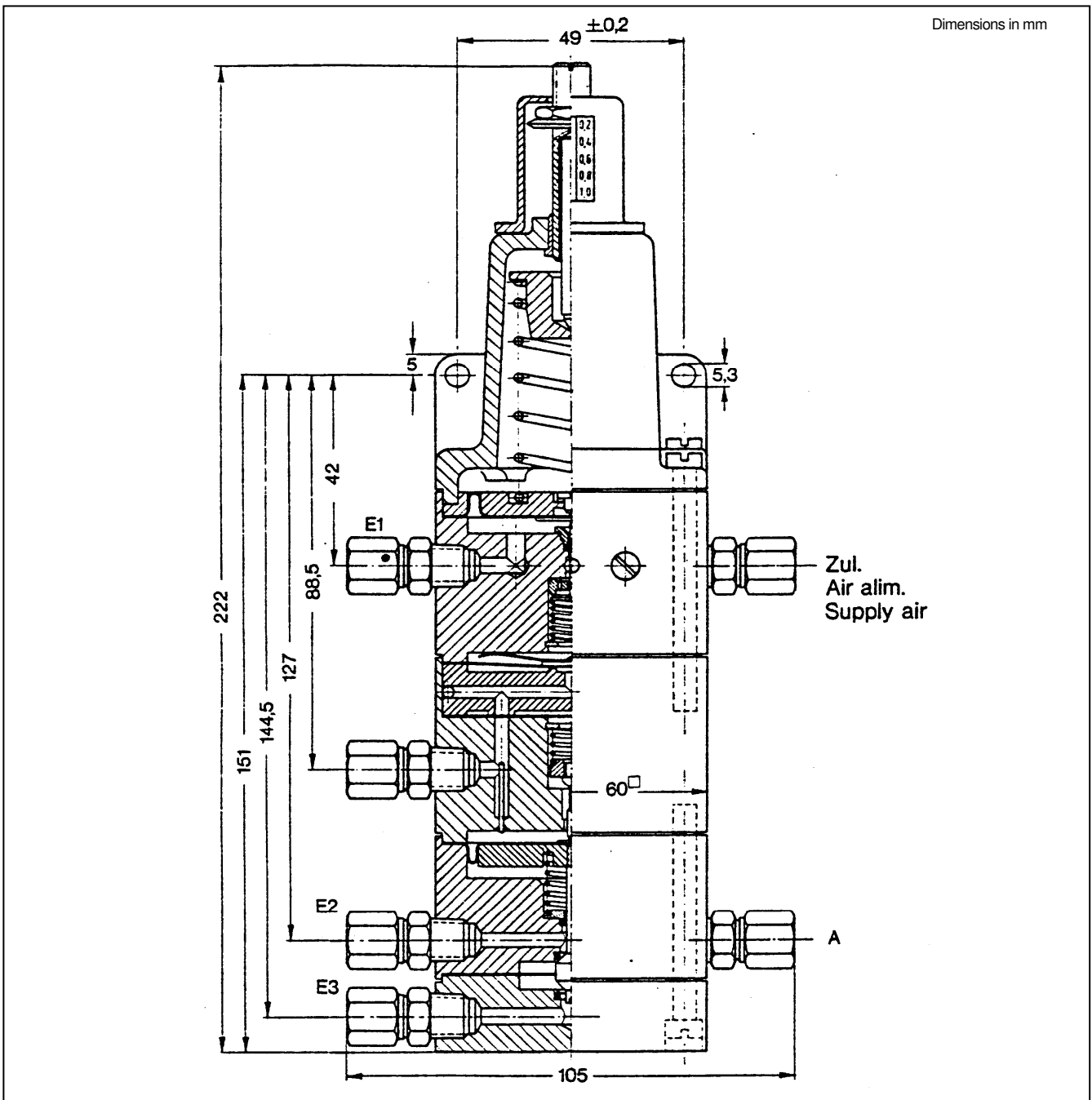

Dimensional drawing shows tube fittings 1/8-NPT for pipe 6 x 1. These are not supplied with the relays and must be ordered separately.

PS953-114 Three-way signal selector relay, mech. setpoint (0 to 1 bar) with self-latch, change-over if setpoint is exceeded, reversing manual

Input E3¹⁾, E4¹⁾ 0 to 6 bar / 0 to 90 psi /
0 to 600 kPa
Output A¹⁾ according to switch position,
E3 or E4
Input E1¹⁾, E2¹⁾ 0.2 to 1 bar / 3 to 15 psi /
20 to 100 kPa,
max. 6 bar / 90 psi / 600 kPa
Supply air 1.4 ± 0.1 bar / 20 ± 1.4 psi /
140 ± 10 kPa, to max. 6 bar /
90 psi / 600 kPa

Setpoint adjustment K
equivalent to 0 to 1 bar / 0 to 15 psi /
0 to 100 kPa,
max. 1.4 bar / 20 psi /
140 kPa
Switching hysteresis. 5 to 6 % due to snap action
changeover
Temperature effect. ≤ 0.5 % / 10 K
Supply air dependency. ≤ 0.3 % / 0.1 bar
Air consumption. 0 / 200 l/h
Air delivery. 3 000 l/h at Δp = 1 bar
Air exhaust 3 000 l/h at Δp = 1 bar
Weight. 1.4 kg

1) Flow direction reversible

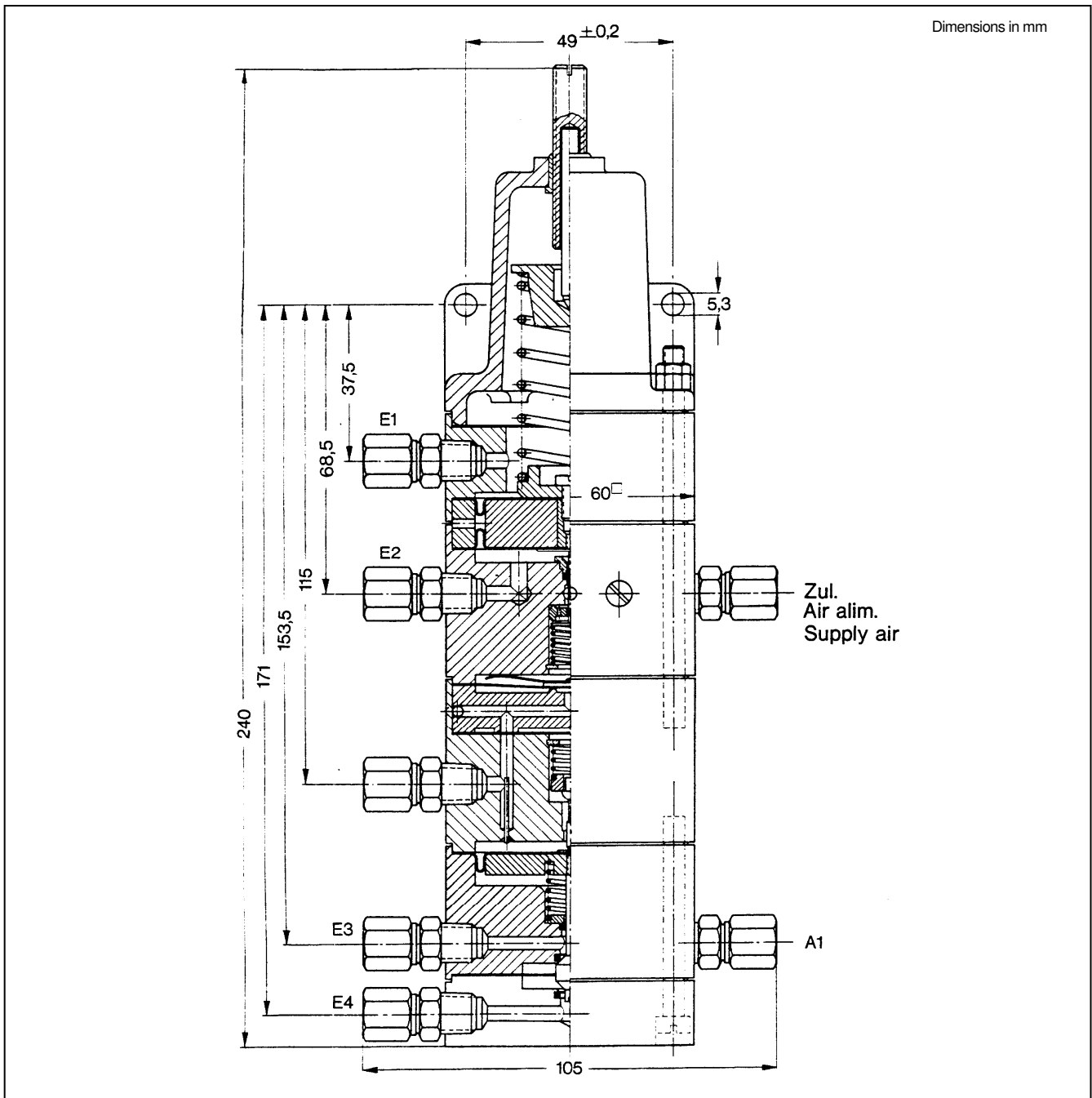

Dimensional drawing shows tube fittings 1/8-NPT for pipe 6 x 1. These are not supplied with the relays and must be ordered separately.

**PS953-200 Lock-in relay,
single-action**

**PS953-210 Lock-in relay,
double-action**

Input E max. 10 bar / max. 150 psi /
max. 1 000 kPa

Output A locked or connected to input

Supply air =

Pilot pressure max. 6 bar / 90 psi / 600 kPa

Setpoint adjustment K

equivalent to 1 to 6 bar / 15 to 90 psi /
100 to 600 kPa

Switching hysteresis 3 % of setpoint

Temperature effect $\leq 0.5\%$ / 10 K

Supply air dependency $\leq 0.3\%$ / 0.1 bar

Air consumption 0 / 100 l/h

Max. air throughput 15 000 l/h at $\Delta p = 1$ bar

Cv 0.25

Pneum. connections internal thread 1/4-NPT

Weight 1.4 kg

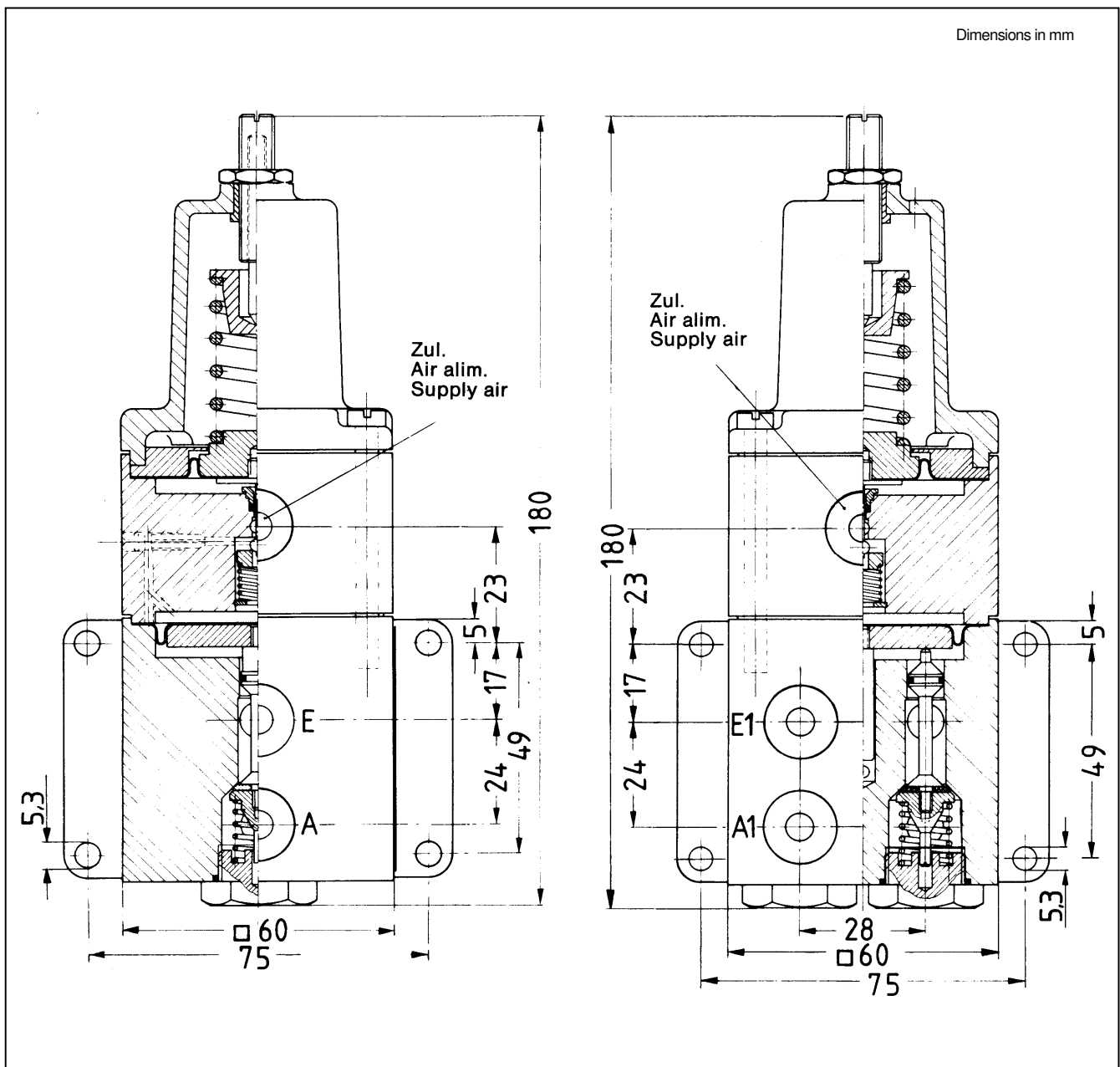

PS953-613 Change-over relay,

pneum. connections 1/4-NPT (and 1/8 NPT for Input E1)

- Input E1 switches E2 to A at pressure0:
0 to 0.2 bar / 0 to 3 psi /
0 to 20 kPa or
. switches E3 to A at pressure1:
1 to 1.4 bar / 15 to 20 psi /
100 to 140 kPa,
max. 6 bar / 90 psi / 600 kPa
- Input E2 ¹⁾, E3 ¹⁾ 0 to 6 bar / 0 to 90 psi /
0 to 600 kPa
- Output A ¹⁾ according to switch position,
E2 or E3
- Air delivery 30 000 l/h at $\Delta p = 1$ bar
- Air exhaust 30 000 l/h at $\Delta p = 1$ bar
- Pneum. connections internal thread 1/4-NPT
- Weight 0.5 kg

1) Flow direction reversible

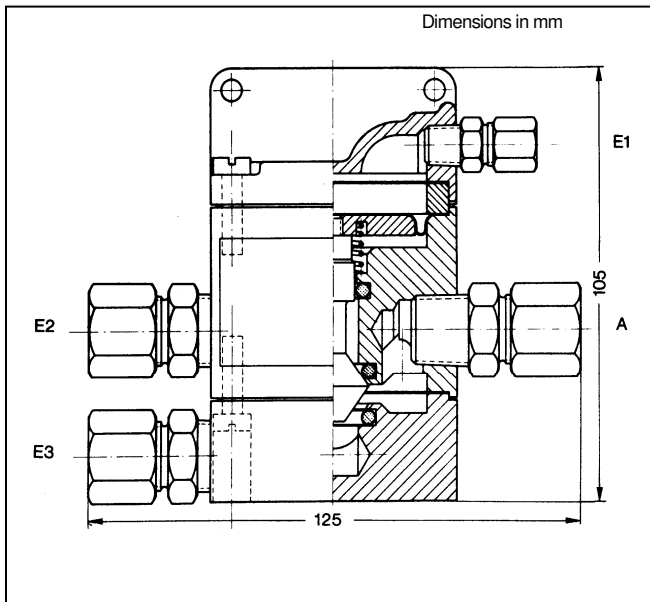

Dimensional drawing shows tube fittings 1/4-NPT (and 1/8 NPT for input E1). These are not supplied with the relays and must be ordered separately.

PS953 Option -A Push-button valve for venting pneum. signal lines

- Push-button valve for panel mounting
- Option -A. push to open

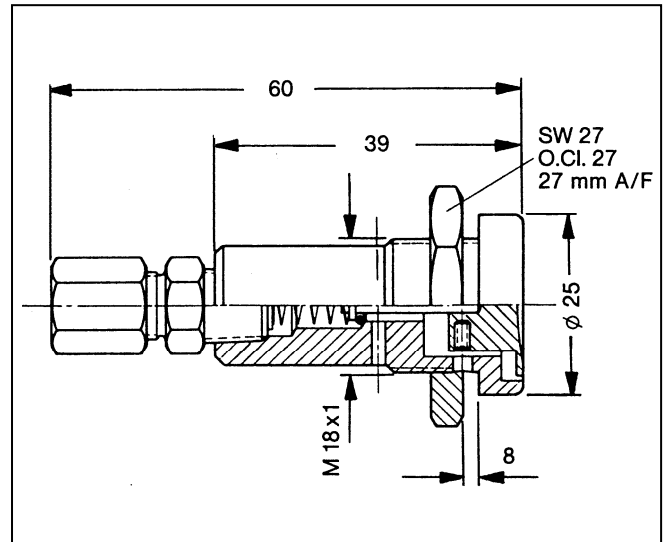

Schneider Electric Systems USA, Inc.
38 Neponset Avenue
Foxboro, MA 02035
United States of America
<http://www.schneider-electric.com>

Global Customer Support
Inside U.S.: 1-866-746-6477
Outside U.S.: 1-508-549-2424
<https://pasupport.schneider-electric.com>

Copyright 2010-2019 Schneider Electric
Systems USA, Inc. All rights reserved.

Schneider Electric is a trademark of
Schneider Electric Systems USA, Inc., its
subsidiaries, and affiliates. All other trademarks
are the property of their respective owners.

